

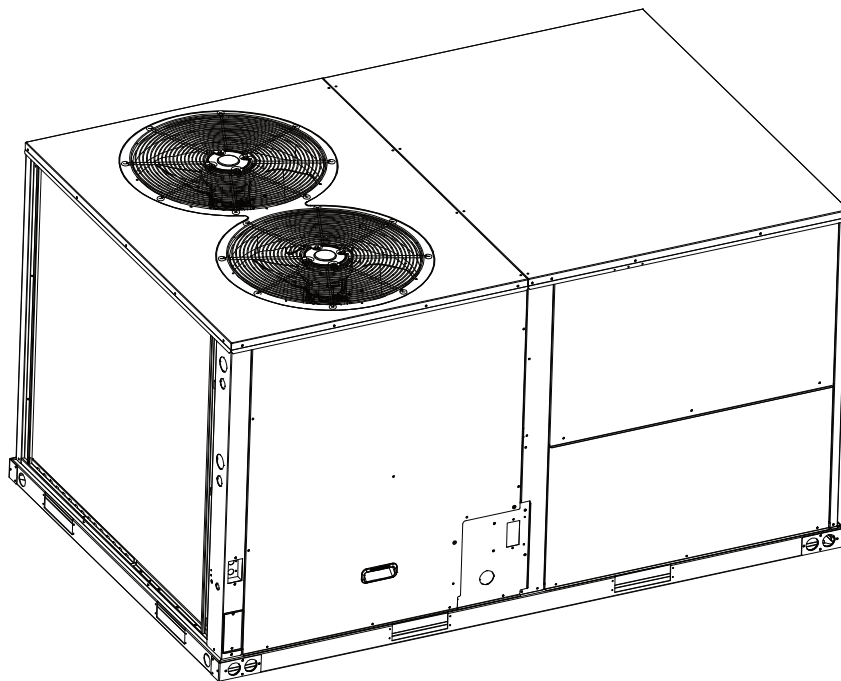

Installation, Operation, and Maintenance

Oxbox Light Commercial Rooftops

Cooling and Gas/Electric
7.5 to 12.5 Tons, 60 Hz



Model Numbers:

PRG*090-150

PRC*090-150

SAFETY WARNING

Only qualified personnel should install and service the equipment. The installation, starting up, and servicing of heating, ventilating, and air-conditioning equipment can be hazardous and requires specific knowledge and training. Improperly installed, adjusted or altered equipment by an unqualified person could result in death or serious injury. When working on the equipment, observe all precautions in the literature and on the tags, stickers, and labels that are attached to the equipment.

October 2023

Introduction

Read this manual thoroughly before operating or servicing this unit.

And keep in a safe place for future reference by a serviceman.

Category I, the combustion system is fan-assisted. A Category I fan-assisted furnace is an appliance equipped with an integral mechanical means to either draw or force products of combustion through the combustion chamber and/or heat exchanger.

Warnings, Cautions, and Notices

Safety advisories appear throughout this manual as required. Your personal safety and the proper operation of this machine depend upon the strict observance of these precautions.

The three types of advisories are defined as follows:



Indicates a potentially hazardous situation which, if not avoided, could result in death or serious injury.



Indicates a potentially hazardous situation which, if not avoided, could result in minor or moderate injury. It could also be used to alert against unsafe practices.



Indicates a situation that could result in equipment or property-damage only accidents.

Important Environmental Concerns

Scientific research has shown that certain man-made chemicals can affect the earth's naturally occurring stratospheric ozone layer when released to the atmosphere. In particular, several of the identified chemicals that may affect the ozone layer are refrigerants that contain Chlorine, Fluorine and Carbon (CFCs) and those containing Hydrogen, Chlorine, Fluorine and Carbon (HCFCs). Not all refrigerants containing these compounds have the same potential impact to the environment. Oxbox advocates the responsible handling of all refrigerants-including industry replacements for CFCs and HCFCs such as saturated or unsaturated HFCs and HCFCs.

Important Responsible Refrigerant Practices

Oxbox believes that responsible refrigerant practices are important to the environment, our customers, and the air conditioning industry. All technicians who handle refrigerants must be certified according to local rules. For the USA, the Federal Clean Air Act (Section 608) sets forth the requirements for handling, reclaiming, recovering and recycling of certain refrigerants and the equipment that is used in these service procedures. In addition, some states or municipalities may have additional requirements that must also be adhered to for responsible management of refrigerants. Know the applicable laws and follow them.

WARNING

Proper Field Wiring and Grounding Required!

Failure to follow code could result in death or serious injury.

All field wiring **MUST** be performed by qualified personnel. Improperly installed and grounded field wiring poses **FIRE** and **ELECTROCUTION** hazards. To avoid these hazards, you **MUST** follow requirements for field wiring installation and grounding as described in NEC and your local/state/national electrical codes.

WARNING

Personal Protective Equipment (PPE) Required!

Failure to wear proper PPE for the job being undertaken could result in death or serious injury.

Technicians, in order to protect themselves from potential electrical, mechanical, and chemical hazards, **MUST** follow precautions in this manual and on the tags, stickers, and labels, as well as the instructions below:

- Before installing/servicing this unit, technicians **MUST** put on all PPE required for the work being undertaken (Examples; cut resistant gloves/sleeves, butyl gloves, safety glasses, hard hat/bump cap, fall protection, electrical PPE and arc flash clothing). **ALWAYS** refer to appropriate Safety Data Sheets (SDS) and OSHA guidelines for proper PPE.
- When working with or around hazardous chemicals, **ALWAYS** refer to the appropriate SDS and OSHA/GHS (Global Harmonized System of Classification and Labelling of Chemicals) guidelines for information on allowable personal exposure levels, proper respiratory protection and handling instructions.
- If there is a risk of energized electrical contact, arc, or flash, technicians **MUST** put on all PPE in accordance with OSHA, NFPA 70E, or other country-specific requirements for arc flash protection, **PRIOR** to servicing the unit. **NEVER PERFORM ANY SWITCHING, DISCONNECTING, OR VOLTAGE TESTING WITHOUT PROPER ELECTRICAL PPE AND ARC FLASH CLOTHING. ENSURE ELECTRICAL METERS AND EQUIPMENT ARE PROPERLY RATED FOR INTENDED VOLTAGE.**

⚠ WARNING**Follow EHS Policies!**

Failure to follow instructions below could result in death or serious injury.

- All Oxbox personnel must follow the company's Environmental, Health and Safety (EHS) policies when performing work such as hot work, electrical, fall protection, lockout/tagout, refrigerant handling, etc. Where local regulations are more stringent than these policies, those regulations supersede these policies.
- Non- Oxbox personnel should always follow local regulations.

⚠ WARNING**Hazard of Explosion or Fire!**

Failure to follow instructions could result in death or serious injury and equipment or property damage.

Do not store or use gasoline or other flammable vapors and liquids in the vicinity of this or any other appliance.

IF YOU SMELL GAS, follow instructions below:

- Do not try to light any appliance.
- Do not touch any electrical switch.
- Do not use any phone in your building.
- Open windows and doors.
- Alert others and evacuate building immediately.
- From a phone outside of the building, immediately call your gas supplier. Follow the gas supplier's instructions. If you cannot reach your gas supplier, call the fire department.

⚠ WARNING

This product can expose you to chemicals including lead, which are known to the state of California to cause cancer and birth defects or other reproductive harm. For more information go to www.p65Warnings.ca.gov

This appliance is not intended for use by persons (including children) with reduced physical, sensory or mental capabilities, or lack of experience and knowledge, unless they have been given supervision or instruction concerning use of the appliance by a person responsible for their safety.

Children should be supervised to ensure that they do not play with the appliance.

Overview of Manual

One copy of this document ships inside the control panel of each unit and is customer property. It must be retained by the unit's maintenance personnel..

Important: *Do not release refrigerant to the atmosphere! If adding or removing refrigerant is required, the service technician must comply with all federal, state, and local laws.*

This booklet describes the proper installation, startup, operation, and maintenance procedures for air cooled systems.

By carefully reviewing the information within this manual and following the instructions, the risk of improper operation and/or component damage will be minimized. It is important that periodic maintenance be performed to help assure trouble free operation. A maintenance schedule is provided at the end of this manual. Should equipment failure occur, contact a qualified service organization with qualified, experienced HVAC technicians to properly diagnose and repair this equipment.

Copyright

This document and the information in it are the property of Oxbox, and may not be used or reproduced in whole or in part without written permission. Oxbox reserves the right to revise this publication at any time, and to make changes to its content without obligation to notify any person of such revision or change.

Trademarks

All trademarks referenced in this document are the trademarks of their respective owners.

Table of Contents

Model Number Description	5	Cooling without an Economizer	23
General Information	6	Evaporator Fan Operation (for Gas Units) - Standard Economizer	23
Overview of Manual	6	Evaporator Fan Operation (for Cooling Only Units) - Standard Economizer	23
Unit Inspection	6	Economizer Set-Up - Standard Economizer	23
Exterior Inspection	6	Cooling with an Economizer - Standard Economizer	23
Inspection for Concealed Damage	6	Heating Operation (Units with Electric Heat) - Standard Economizer	23
Unit Storage	6	Heating Operation (for Gas Units) - Standard Economizer	24
Unit Description	7	Ignition Module Low, Medium and High Heat	24
System Input Devices and Functions	7	Two-Speed Indoor Fan Control	24
Sensors	7	Cooling Operation	24
Dimensional Data	8	Low Pressure Cutout	24
Weights	12	High Pressure Cutout and Temperature Discharge Limit	25
Rigging	12	Heating Operation	25
Installation	14	Emergency Stop	25
Unit Foundation	14	Compressor Start-Up	25
Horizontal Units	14	Heating Start-Up	26
Ductwork	14	Final System Set Up	26
General Unit Requirements	14	Maintenance	27
Main Electrical Power Requirements	15	Fan Belt Adjustment-Belt Drive Units	27
External Vent Hood Installation	15	Monthly Maintenance	28
Condensate Drain Configuration	15	Filters	28
Filter Installation	15	Condensate Overflow Switch	28
Field Installed Power Wiring	15	Cooling Season	28
Main Unit Power	16	Heating Season	29
Standard Wiring	16	Coil Cleaning	29
Control Power Transformer	16	Troubleshooting	32
Controls using 24 Vac	16	Standard Troubleshooting	32
Gas Heat Data	18	Ignition Module	32
Voltage Imbalance	19	Failures	32
Electrical Phasing (Three Phase Motors)	19	To Clear an Alarm	32
Checklist	20	Resetting Cooling and Heating Lockouts	32
External Unit Power Supply	20	Method 1	32
Unit Disconnect Wiring Plan	20	Method 2	33
Through the Base Gas Utility Option	21	Wiring Diagrams	35
Field Installed Connections	21	Exclusions and Limitations	36
Pre Start	22	Horizontal Duct Conversion instruction	37
Verifying Proper Air Flow (Units with Belt Drive Indoor Fan)	22		
Electromechanical Controls – Test Procedure	22		
Start Up	23		
Electromechanical Controls - Sequence Of Operation	23		

Model Number Description

Digit 1 — Oxbox Brand

J = Oxbox Brand

Digit 2 — Refrigerant

4 = R410A

5 = R454B

Digit 3 — Product Family

PR = Packaged Rooftop

Digit 5 — Unit Type

C = Cooling Only (field installed electric heat)

G = Gas Heat

Digit 6 — IEER2 rating

4 = 14.8 IEER2

5 = 14.2 IEER2

Digit 7-9 — Tonnage

090 = 7.5 Tons

102 = 8.5 Tons

120 = 10 Tons

150 = 12.5 Tons

Digit 10 — Major Design Sequence

A = Rev A

B = Rev B

Digit 11 — Voltage Selection

3 = 208-230/60/3

4 = 460/60/3

Digit 12 — Unit Controls

E = Electromechanical

Digit 13 — Heating Capacity

0 = Cooling Only (field installed electric heat)

L = Gas Heat - Low

M = Gas Heat - Medium

H = Gas Heat - High

Digit 14 — Version Number

A = Minor Design Sequence

General Information

WARNING

Fiberglass Wool!

Exposure to glass wool fibers without all necessary PPE equipment could result in cancer, respiratory, skin or eye irritation, which could result in death or serious injury. Disturbing the insulation in this product during installation, maintenance or repair will expose you to airborne particles of glass wool fibers and ceramic fibers known to the state of California to cause cancer through inhalation.

You **MUST** wear all necessary Personal Protective Equipment (PPE) including gloves, eye protection, a NIOSH approved dust/mist respirator, long sleeves and pants when working with products containing fiberglass wool.

Precautionary Measures:

- Avoid breathing fiberglass dust.
- Use a NIOSH approved dust/mist respirator.
- Avoid contact with the skin or eyes. Wear long-sleeved, loose-fitting clothing, gloves, and eye protection.
- Wash clothes separately from other clothing; rinse washer thoroughly.
- Operations such as sawing, blowing, tear-out, and spraying may generate fiber concentrations requiring additional respiratory protection. Use the appropriate NIOSH approved respirator.

First Aid Measures:

- **Eye Contact** - Flush eyes with water to remove dust. If symptoms persist, seek medical attention.
- **Skin Contact** - Wash affected areas gently with soap and warm water after handling.

Overview of Manual

Note: One copy of this document ships inside the control panel of each unit and is customer property. It must be retained by the unit's maintenance personnel.

This booklet describes proper installation, operation, and maintenance procedures for air cooled systems. By carefully reviewing the information within this manual and following the instructions, the risk of improper operation and/or component damage will be minimized.

It is important that periodic maintenance be performed to help assure trouble free operation. A maintenance schedule is provided at the end of this manual.

Unit Inspection

To protect against loss due to damage incurred in transit, perform inspection immediately upon receipt of the unit. Check carefully for shipping damage. If any damage is found, report it immediately, and file a claim against the transportation company.

Exterior Inspection

If the job site inspection reveals damage or material shortages, file a claim with the carrier immediately. Specify the type and extent of the damage on the bill of lading before signing. Notify the appropriate sales representative.

Important: Do not proceed with installation of a damaged unit without sales representative approval.

- Inspect the complete exterior for signs of shipping damages to unit or packing material.
- Verify that the nameplate data matches the sales order and bill of lading.
- Verify that the unit is properly equipped and there are no material shortages.
- Verify the power supply complies with the unit nameplate specifications.

Inspection for Concealed Damage

Inspect the components for concealed damage as soon as possible after delivery and before it is stored.

If concealed damage is discovered:

- Notify the carrier's terminal of the damage immediately by phone and by mail.
- Concealed damage must be reported within 15 days.
- Request an immediate, joint inspection of the damage with the carrier and consignee.
- Stop unpacking the unit.
- Do not remove damaged material from receiving location.
- Take photos of the damage, if possible.
- The owner must provide reasonable evidence that the damage did not occur after delivery.

Unit Storage

Take precautions to prevent condensate from forming inside the unit's electrical compartments and motors if:

- The unit is stored before it is installed; or,
- The unit is set on the roof curb, and temporary heat is provided in the building. Isolate all side panel service entrances and base pan openings (e.g., conduit holes, S/A and R/ A openings, and flue openings) from the ambient air until the unit is ready for start-up.

General Information

Note: Do not use the unit's heater for temporary heat without first completing the start-up.

The manufacturer will not assume any responsibility for equipment damage resulting from condensate accumulation on the unit's electrical and/or mechanical components.

Unit Description

Before shipment, each unit is leak tested, dehydrated, charged with refrigerant and compressor oil, and run tested for proper control operation.

Direct-drive, vertical discharge condenser fans are provided with built-in thermal overload protection.

System Input Devices and Functions

The unit must have a thermostat input in order to operate.

The descriptions of the following basic input devices used within the unit are to acquaint the operator with their function as they interface with the various features. Refer to the unit's electrical schematic for the specific device connections. The following controls are available from the factory for field installation.

Drain Pan Condensate Overflow Switch (Optional)

This input incorporates the Condensate Overflow Switch (COF) mounted on the drain pan. When the condensate level reaches the trip point, the COF relay energizes and opens the 24 Vac control circuit, disabling the unit. A delay timer prevents the unit from starting for 7 minutes.

Discharge Line Thermostat Control

The high pressure controls and the discharge line thermostat signals are wired in series and connected to the safety input of the LSD. The compressor contactor coil is connected to the 'CC' terminal of the LSD. If the high pressure control switch or the discharge line thermostat is open, the 24 Vac signal to the SI input of the LSD is interrupted and the compressor contactor coil supply is disabled by the LSD. It has an automatic lockout.

The high pressure controls and discharge line thermostats are wired in the system protection detection port. If the high pressure control switch or the discharge line thermostat is open, the main control board will turn off the compressor of the corresponding system. There is no automatic lockout.

Evaporator Frost Control

This input incorporates the Evaporator Frost Control mounted in the indoor coil and can be activated by closing

a field supplied contact installed in parallel with the Frost Control.

If this circuit is open before the compressor is started, the compressor will not be allowed to operate. Anytime this circuit is opened for 5 continuous seconds during compressor operation, the compressor for that circuit is immediately turned "Off". The compressor will not be allowed to restart for a minimum of 3 minutes should the Frost Control close.

Dimensional Data

Below figure illustrates the minimum operating and service clearances for either a single or multiple unit installation. These clearances are the minimum distances necessary to assure adequate serviceability, cataloged unit capacity, and peak operating efficiency.

Providing less than the recommended clearances may result in condenser coil starvation, "short-circuiting" of exhaust and economizer airflows, or recirculation of hot condenser air.

Figure 1. Typical installation clearance for single and multiple unit applications (in inches)

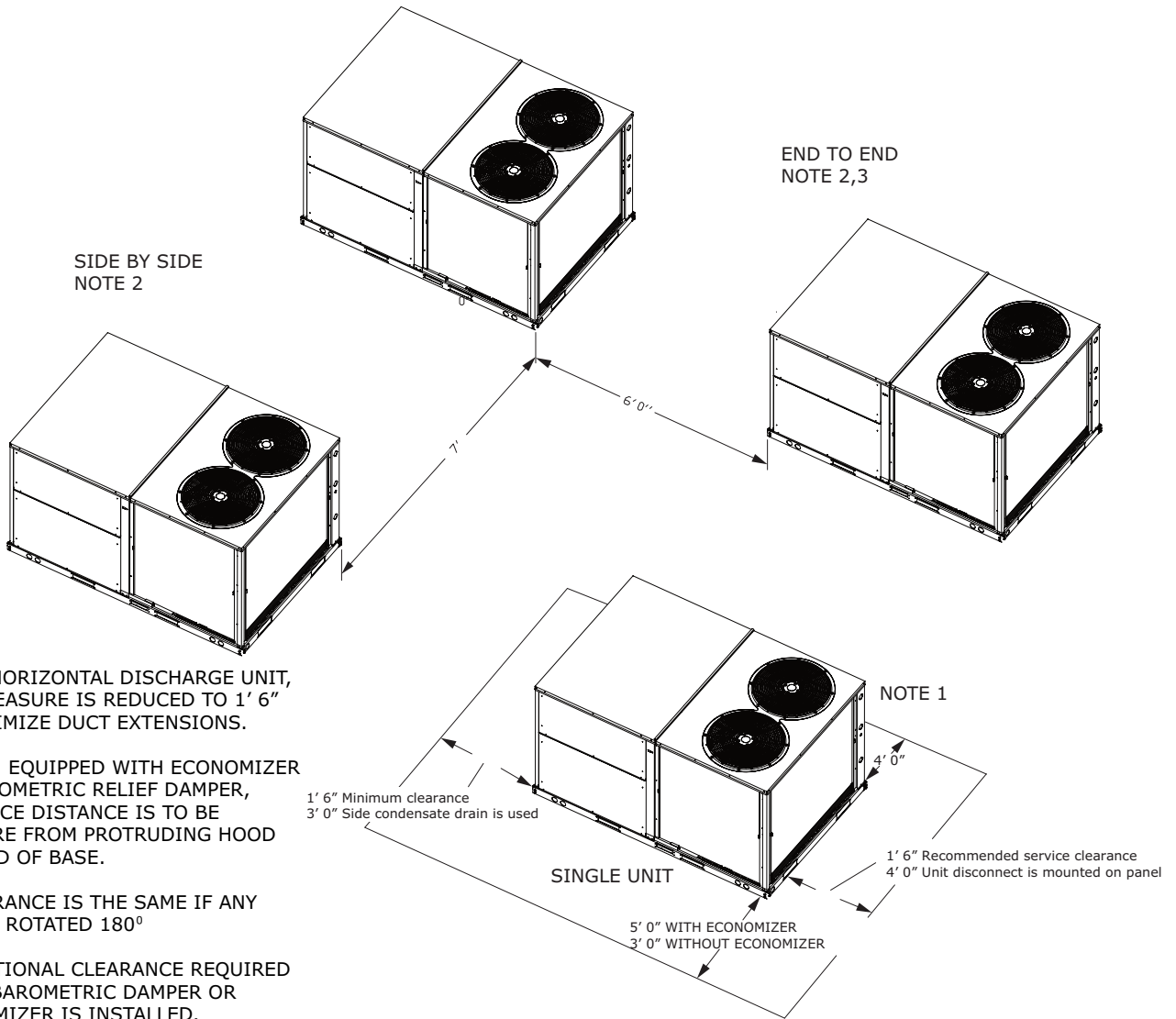

NOTES:

1. FOR HORIZONTAL DISCHARGE UNIT, THIS MEASURE IS REDUCED TO 1' 6" TO MINIMIZE DUCT EXTENSIONS.

2. WHEN EQUIPPED WITH ECONOMIZER OR BAROMETRIC RELIEF DAMPER, CLEARANCE DISTANCE IS TO BE MEASURED FROM PROTRUDING HOOD INSTEAD OF BASE.

3. CLEARANCE IS THE SAME IF ANY UNIT IS ROTATED 180°

3. ADDITIONAL CLEARANCE REQUIRED WHEN BAROMETRIC DAMPER OR ECONOMIZER IS INSTALLED.

Dimensional Data

Figure 2. Gas units — overview

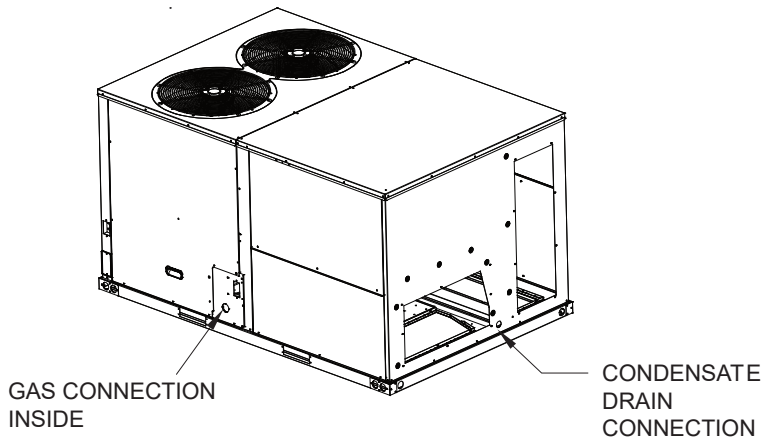

Electric units — overview

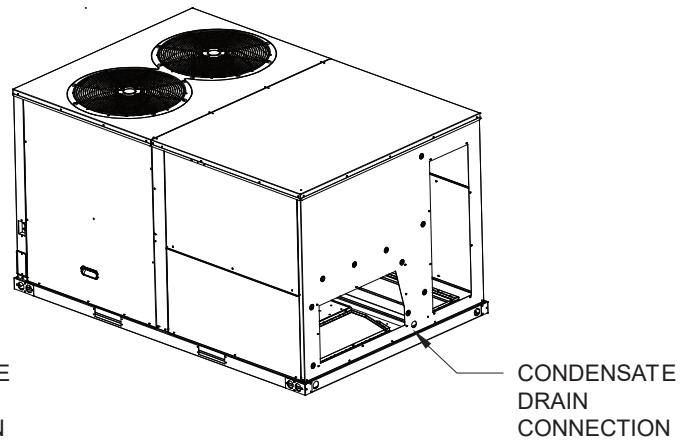
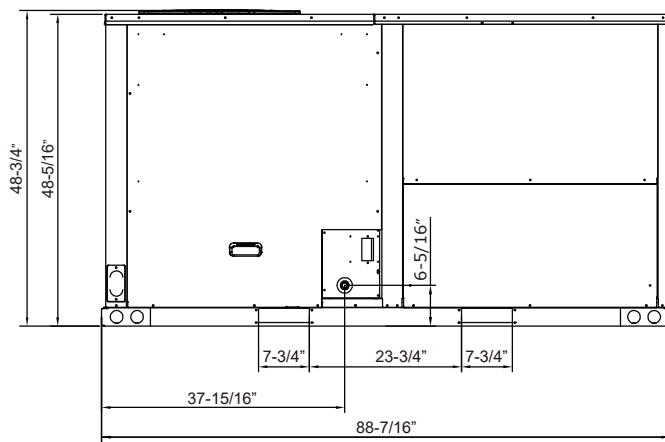

Figure 3. Gas units — front and side views (in inches)



Electric units — front and side views (in inches)

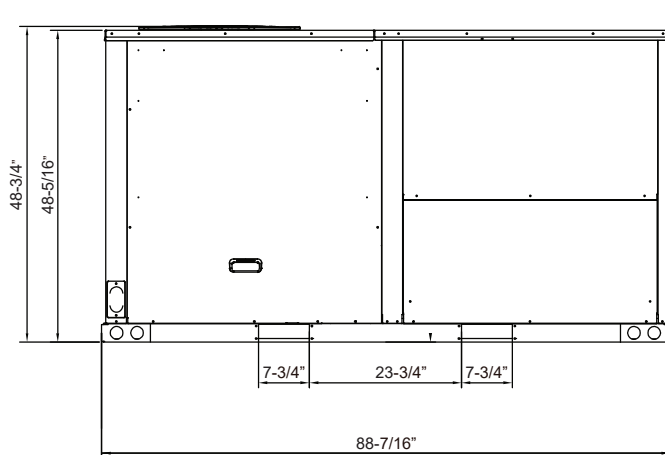
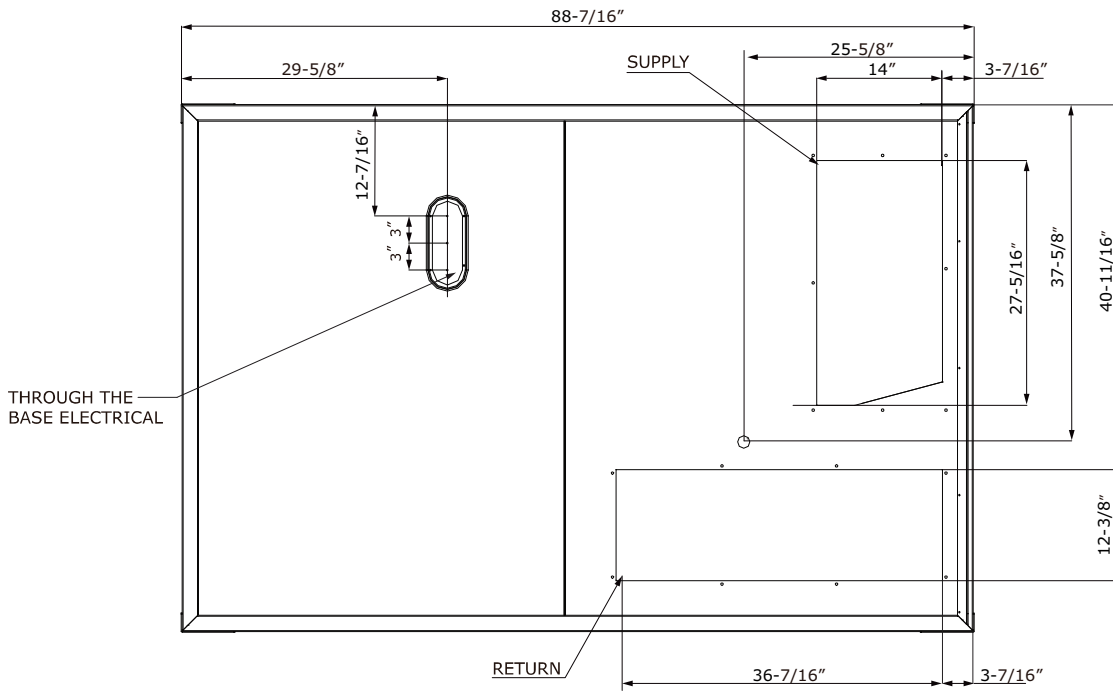

Figure 4. Oxbox units — bottom view (in inches)



NOTES:

1. THROUGH THE BASE GAS AND ELECTRICAL IS NOT STANDARD ON ALL UNITS.
2. VERIFY WEIGHT, CONNECTION, AND ALL DIMENSION WITH INSTALLER DOCUMENTS BEFORE INSTALLATION.

Figure 5. Oxbox units — back view (horizontal configuration) (in inches)

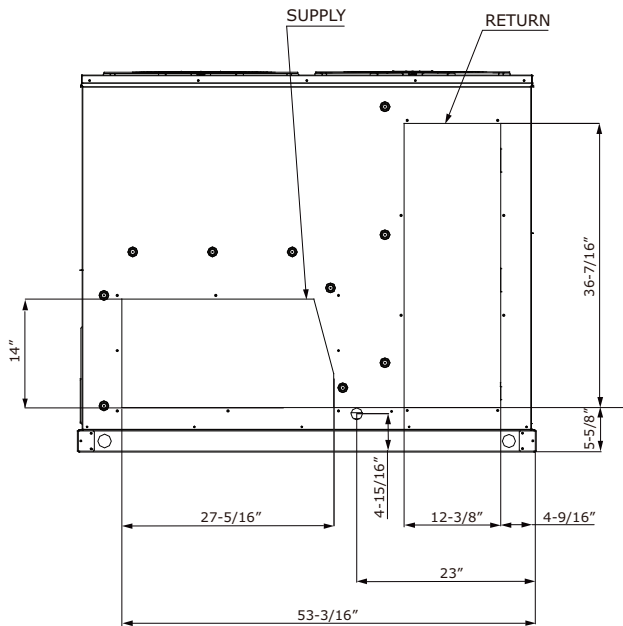

Dimensional Data

Figure 6. Roof curb (in inches)

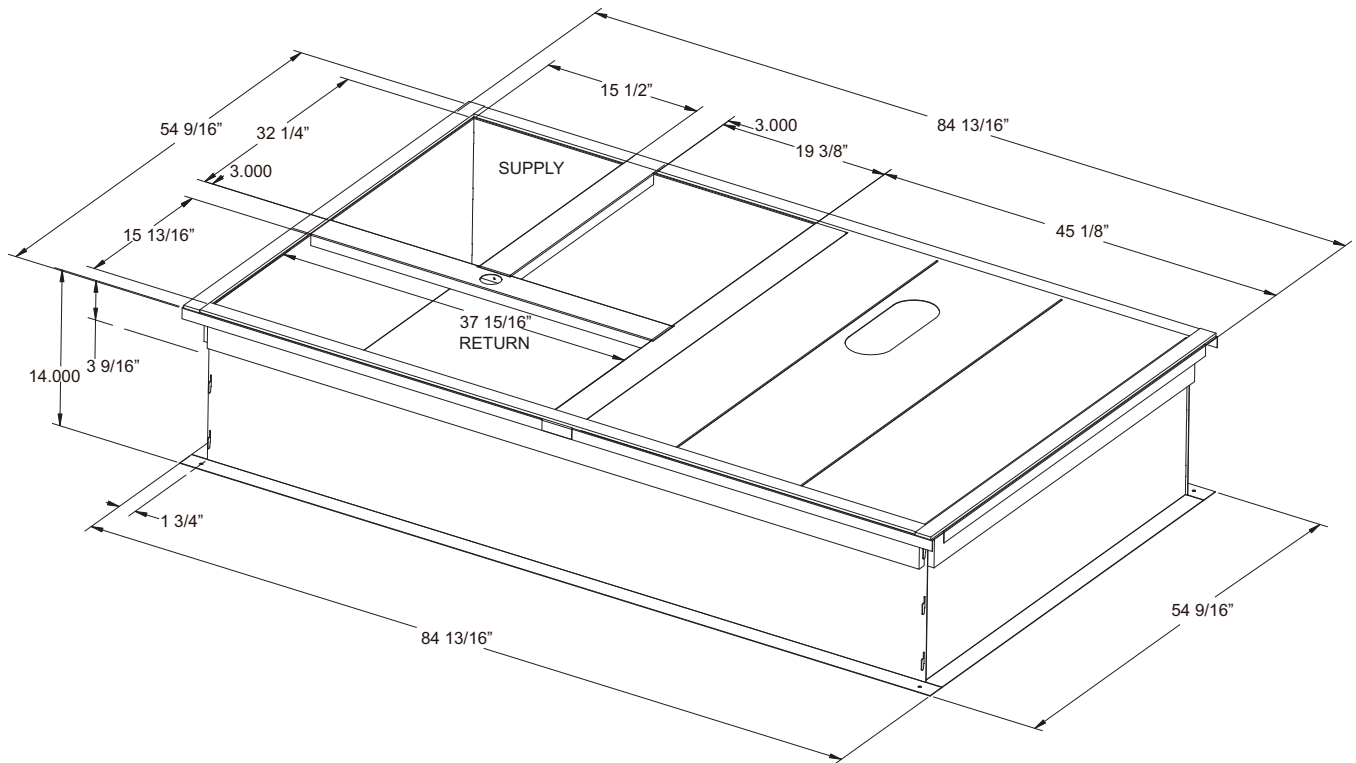
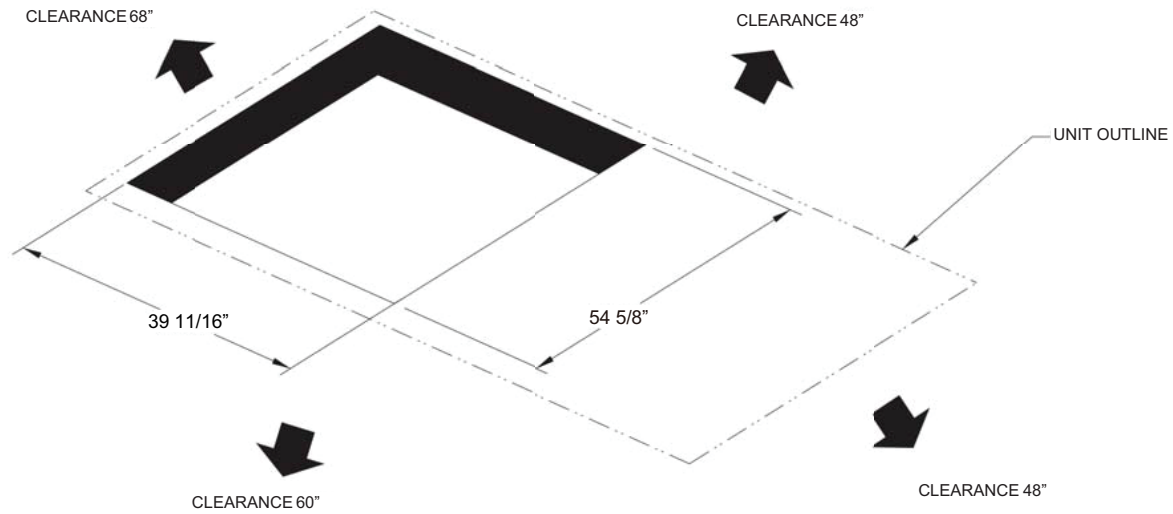

Figure 7. Downflow unit clearance (in inches)



Weights

Table 1. Maximum unit and corner weights (lb) and center of gravity dimensions (in.)

Tons	Unit Model No.	Weights (lb) ^(a) , ^(b)		Corner Weights ^(c)				Center of Gravity (in.)	
		Shipping	Net	A	B	C	D	Length	Width
7.5	PRG4090A	1087	1012	248	181	334	249	45.0	34.0
8.5	PRG4102A	1111	1036	236	176	340	283	44.0	36.0
10	PRG4120A	1133	1058	237	190	273	358	39.0	34.0
12.5	PRG5150A	1235	1172	264	194	299	416	39.0	35.0
7.5	PRC090A	979	904	250	188	197	269	45.0	34.0
8.5	PRC102A	1003	928	252	187	200	289	44.0	36.0
10	PRC120A	1023	948	277	180	187	304	39.0	34.0
12.5	PRC150A	1124	1049	302	197	208	342	39.0	35.0

^(a) Weights are approximate. Horizontal and downflow unit and corner weights may vary slightly.

^(b) Weights do not include additional factory or field installed options/accessories.

^(c) Corner weights are given for information only. 7.5–12.5 ton models must be supported continuously by a curb or equivalent frame support.

Figure 8. Center of gravity/corner weights

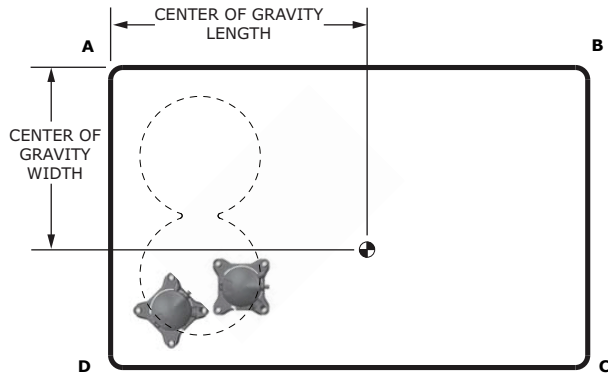

Refer to [Figure 9, p. 14](#) and for typical unit operating weights rigging before proceeding.

1. Remove the shipping crate from around the unit. Do not remove the crating from the top of the unit.
2. Rig the unit as shown in [Figure 9, p. 14](#). Attach adequate strength lifting slings to all four lifting brackets in the unit base rail. Do not use cables, chains, or slings except as shown.
3. Install a lifting bar, as shown in [Figure 9, p. 14](#), to protect the unit and to facilitate a uniform lift. The minimum distance between the lifting hook and the top of the unit should be 7 feet.
4. Test-lift the unit to ensure it is properly rigged and balanced, make any necessary rigging adjustments.
5. Lift the unit and position it into place.
6. Downflow units; align the base rail of the unit with the curb rail while lowering the unit onto the curb. Make sure that the gasket on the curb is not damaged while positioning the unit.

Rigging

WARNING

Heavy Object!

Failure to follow instructions below could result in unit dropping which could result in death or serious injury, and equipment or property-only damage.

Ensure that all the lifting equipment used is properly rated for the weight of the unit being lifted. Each of the cables (chains or slings), hooks, and shackles used to lift the unit must be capable of supporting the entire weight of the unit. Lifting cables (chains or slings) may not be of the same length. Adjust as necessary for even unit lift.

WARNING

Improper Unit Lift!

Failure to properly lift unit in a LEVEL position could result in unit dropping and possibly crushing operator/technician which could result in death or serious injury, and equipment or property-only damage.

Test lift unit approximately 24 inches (61 cm) to verify proper center of gravity lift point. To avoid dropping of unit, reposition lifting point if unit is not level.

Figure 9. Rigging and center of gravity data

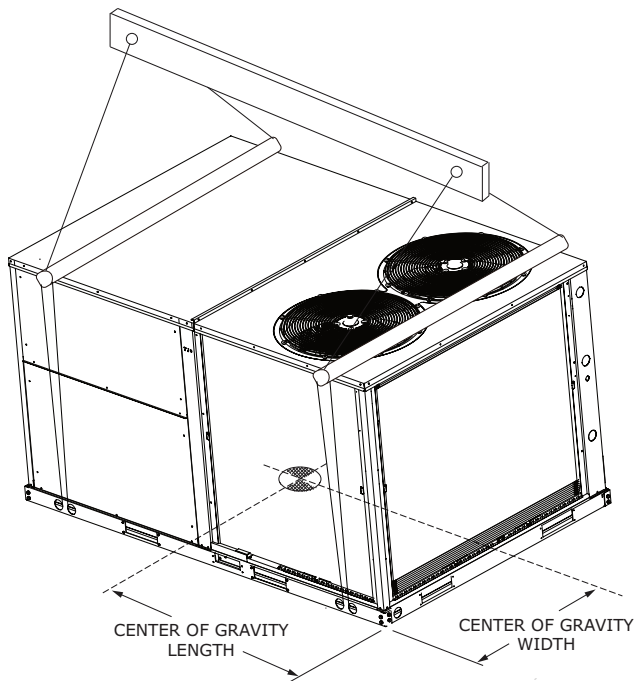

Installation

Unit Foundation

WARNING

Risk of Roof Collapsing!

Failure to ensure proper structural roof support could cause the roof to collapse, which could result in death or serious injury and property damage.

Confirm with a structural engineer that the roof structure is strong enough to support the combined weight of the roof curb, the unit, and any accessories.

NOTICE

Water Damage!

Failure to follow instructions below could result in equipment and property damage.

Non-factory penetrations through the base of this unit are not allowed. Any penetration in the base of the unit may affect the water tight integrity of the unit and lead to water leaks into the conditioned space.

Horizontal Units

NOTICE

Potential Overheating Condition!

Failure to follow instructions could result in equipment damage.

Do not convert high heat units to horizontal airflow configuration. These models are designed for downflow applications only.

Notes:

- For units with optional Condensate Overflow Switch (COF) accessory kit, the switch will not work properly if unit is not level or slightly sloped toward switch.
- To assure proper condensate flow during operation the unit and the curb must be level.

If the unit is installed at ground level, elevate it above the snow line. Provide concrete footings at each support location with a “full perimeter” support structure or a slab foundation for support. Refer to for the unit’s operating and point loading weights when constructing a footing foundation.

If anchoring is required, anchor the unit to the slab using hold down bolts or isolators. Isolators should be installed to minimize the transmission of vibrations into the building.

For rooftop applications, if anchoring is required, anchor the unit to the roof with hold-down bolts or isolators.

Check with a roofing contractor for proper waterproofing procedures.

Ductwork

Elbows with turning vanes or splitters are recommended to minimize air noise due to turbulence and to reduce static pressure.

When attaching the ductwork to the unit, provide a watertight flexible connector at the unit to prevent operating sounds from transmitting through the ductwork.

All outdoor ductwork between the unit and the structure should be weather proofed after installation is completed.

Note: For sound consideration, cut only the holes in the roof deck for the ductwork penetrations. Do not cut out the entire roof deck within the curb perimeter.

If a Curb Accessory Kit is not used:

1. The ductwork can be attached directly to the factory-provided flanges around the unit’s supply and return air openings. Be sure to use flexible duct connections at the unit.
2. For “built-up” curbs supplied by others, gaskets must be installed around the curb perimeter flange and the supply and return air opening flanges.

General Unit Requirements

WARNING

Proper Field Wiring and Grounding Required!

Failure to follow code could result in death or serious injury.

All field wiring MUST be performed by qualified personnel. Improperly installed and grounded field wiring poses FIRE and ELECTROCUTION hazards. To avoid these hazards, you MUST follow requirements for field wiring installation and grounding as described in NEC and your local/state/national electrical codes.

The checklist listed below is a summary of the steps required to successfully install a commercial unit. This checklist is intended to acquaint the installing personnel with what is required in the installation process. It does not replace the detailed instructions called out in the applicable sections of this manual.

- Check the unit for shipping damage and material shortage; file a freight claim and notify appropriate sales representative.
- Verify correct model, options and voltage from nameplate.
- Verify that the installation location of the unit will provide the required clearance for proper operation.
- Assemble and install the roof curb (if applicable). Refer to the latest edition of the curb installers guide that ships with each curb kit.

Installation

- Fabricate and install ductwork; secure ductwork to curb.
- Rigging the unit.
- Set the unit onto the curb; check for levelness.
- Ensure unit-to-curb seal is tight and without buckles or cracks.
- Install and connect a condensate drain line to the evaporator drain connection.

Main Electrical Power Requirements

- Verify that the power supply complies with the unit nameplate specifications.
- Inspect all control panel components; tighten any loose connections.
- Connect properly sized and protected power supply wiring to a field-supplied/ installed disconnect switch and to the main power terminal block in the unit control panel.
- Install proper grounding wires to an earth ground.

Note: All field-installed wiring must comply with NEC and applicable local codes.

External Vent Hood Installation

WARNING

Hazardous Voltage!

Failure to disconnect power before servicing could result in death or serious injury.

Disconnect all electric power, including remote disconnects before servicing. Follow proper lockout/tagout procedures to ensure the power can not be inadvertently energized. Verify that no power is present with a voltmeter.

1. Remove and discard the cover plate located on the gas heat panel.

Important:

- *Make sure you read the label located on the cover plate before you discard it.*
- *Do not discard the fastening screws! They will be needed to install the vent hood.*

2. Locate the vent hood behind the panel, along the base of the unit.
3. Install the vent hood on the gas heat panel using the screws removed in Step 1. Make sure it is properly secured to the panel.

Figure 10. Vent hood installation

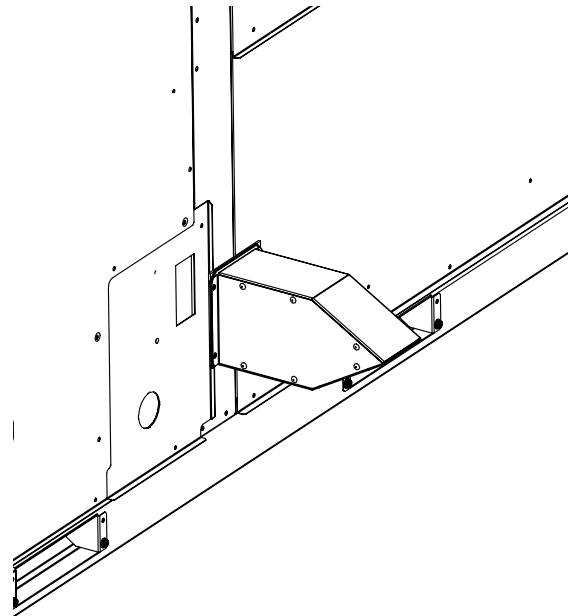

Condensate Drain Configuration

An evaporator condensate drain connection is provided on each unit. Refer to “Dimensional Data,” p. 9 for the appropriate drain location.

Note: Use 1-inch PVC pipe to connect to the drain pan outlet provided in the unit. This is a slip fit joint (no threads). Do not use PVC glue to connect condensate drain, thread sealing compound or Teflon tape may be used.

A condensate trap must be installed at the unit due to the drain connection being on the “negative pressure” side of the fan.

A condensate drain line must be connected to the P-Trap. Pitch the drain lines at least 0.5-inch for every 10 feet of horizontal run to assure proper condensate flow. Do not allow the horizontal run to sag causing a possible doubletrap condition which could result in condensate backup due to “air lock”.

Filter Installation

Each unit ships with 2-inch filters installed. The quantity of filters is determined by unit size. Access to the filters is obtained by removing the filter access panel.

Note: Do not operate the unit without filters.

Field Installed Power Wiring

An overall dimensional layout for the standard field installed wiring entrance into the unit is illustrated in “Dimensional Data,” p. 9. To insure the unit’s supply power wiring is properly sized and installed, follow the guidelines outlined below.

Note: All field installed wiring must conform to NEC guidelines as well as state and Local codes.

Verify that the power supply available is compatible with the unit's nameplate ratings. The available supply power must be within 10 percent of the rated voltage stamped on the nameplate. Use only copper conductors to connect the power supply to the unit.

NOTICE

Use Copper Conductors Only!

Failure to use copper conductors could result in equipment damage as the equipment was not designed or qualified to accept other types of conductors.

Important: A field supplied disconnect switch must be installed at or near the unit in accordance with the National Electrical Code (NEC latest edition).

Main Unit Power

WARNING

Proper Field Wiring and Grounding Required!

Failure to follow code could result in death or serious injury.

All field wiring **MUST** be performed by qualified personnel. Improperly installed and grounded field wiring poses **FIRE** and **ELECTROCUTION** hazards. To avoid these hazards, you **MUST** follow requirements for field wiring installation and grounding as described in NEC and your local/state/national electrical codes.

Standard Wiring

The electrical service must be protected from over current and short circuit conditions in accordance with NEC requirements.

Protection devices must be sized according to the electrical data on the nameplate.

- A field supplied disconnect switch must be installed at or near the unit in accordance with the National Electrical Code (NEC latest edition).
- Location of the applicable electrical service entrance is illustrated in "Dimensional Data," p. 9. Complete the unit's power wiring connections onto either; the main terminal block inside the unit control panel, or the electric heat terminal block. Refer to the customer connection diagram that shipped with the unit for specific termination points.
- Provide proper grounding for the unit in accordance with local and national codes.

Control Power Transformer

The 24-volt control power transformers are to be used only with the accessories called out in this manual.

Controls using 24 Vac

Before installing any connecting wiring, refer to "Dimensional Data," p. 9 for the electrical access locations provided on the unit and for AC conductor sizing guidelines.

NOTICE

Use Copper Conductors Only!

Failure to use copper conductors could result in equipment damage as the equipment was not designed or qualified to accept other types of conductors.

1. Use copper conductors unless otherwise specified.
2. Ensure that the AC control wiring between the controls and the unit's termination point does not exceed three (3) ohms/conductor for the length of the run.
Note: Resistance in excess of 3 ohms per conductor could cause component failure due to insufficient AC voltage supply.
3. Be sure to check all loads and conductors for grounds, shorts, and mis-wiring.
4. Do not run the AC low voltage wiring in the same conduit with the high voltage power wiring.

Table 2. Electromechanical thermostat 24V AC conductors with electromechanical unit

Distance from Unit to Control	Recommended Wire Size
0 - 30 feet	22 gauge
0 - 9.1 m	0.33 mm ²
31 - 50 feet	20 gauge
9.5 - 15.2 m	0.50 mm ²
51 - 75 feet	18 gauge
15.5 - 22.9 m	0.75 mm ²
76 - 125 feet	16 gauge
23.1 - 38.1 m	1.3 mm ²

Installation

Table 2. Electromechanical thermostat 24V AC conductors with electromechanical unit (continued)

Distance from Unit to Control	Recommended Wire Size
126 - 200 feet	14 gauge
38.4 - 60.9 m	2.0 mm ²

Figure 11. Conventional thermostat field wiring diagram

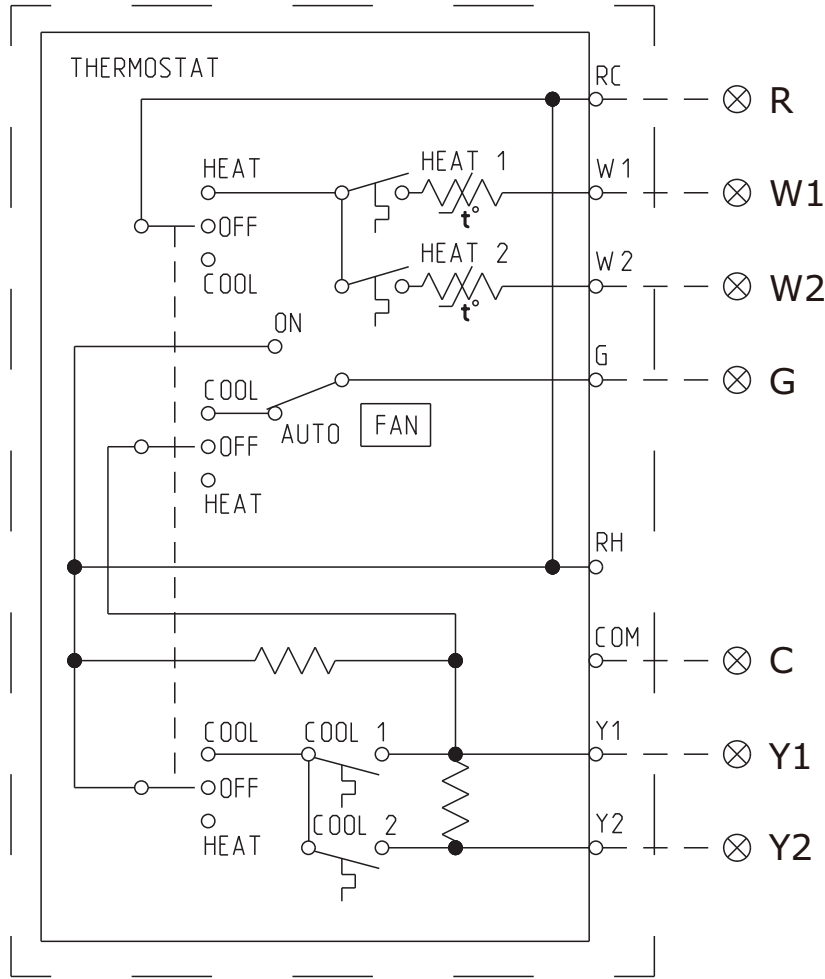

Gas Heat Data

Table 3. Gas heater operating data

Heating Input Rate —Btu/h	125,000	180,000	225,000	250,000
Minimum Supply Gas Pressure Natural/LP	4.5/11.0	4.5/11.0	4.5/11.0	4.5/11.0
Manifold Gas Pressure ^(a)	3.5	3.9	3.6	3.5
Combustion Blower Suction Pressure (1 st Stage)	-1.3 to -1.7	-1.3 to -1.7	-1.1 to -1.5	-1.1 to -1.5
Combustion Blower Suction Pressure (2 nd Stage)	-1.3 to -1.7	-1.3 to -1.7	-1.1 to -1.5	-1.1 to -1.5
Minimum Flame Sensing Current ^(b)	5.0 Micro Amps DC			
Normal Sensing Current Range	8.0 to 16 Micro Amps DC			
Flue Gas Temperature Rise Above Ambient	230 to 300 F			
Flue Gas Content - % CO ₂	7.0% to 8.0% (Natural Gas) 7.5% to 9.0% (Propane)			
Minimum Supply Air Temperature Across Heat Exchanger	40° F			

^(a) Staged gas heat units have a positive pressure gas valve. Never adjust the staged gas pressure valve to a negative pressure.

^(b) A voltage reading across pens (V+) and (V-) is equatable to the flame sensing current. One volt equals one micro amp.

Table 4. Piping

Length of Pipe (ft)	Iron Pipe Size (IPS) Inches				
	1/2" Pipe	3/4" Pipe	1" Pipe	1 1/4" Pipe	1 1/2" Pipe
15	76	176	345	750	1220
30	52	120	241	535	850
45	43	99	199	435	700
60	38	86	173	380	610
75	35	77	155	345	545

Note: Capacity of Pipe of Different Diameters and Lengths in Cu. Ft. Per Hr. with Pressure Drop of 0.3" and Specific Gravity of 0.60.

Table 5. Specific gravity multipliers

Specific Gravity	Multipliers
0.50	1.10
0.55	1.04
0.60	1.00
0.65	0.96

Figure 12. Schematic diagram for field gas piping to units

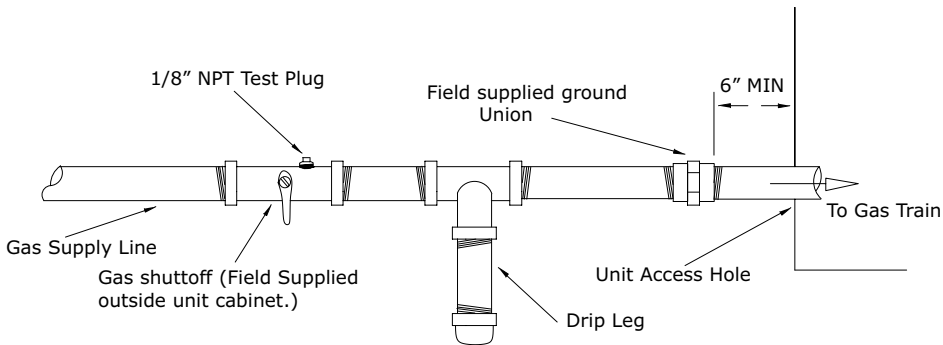
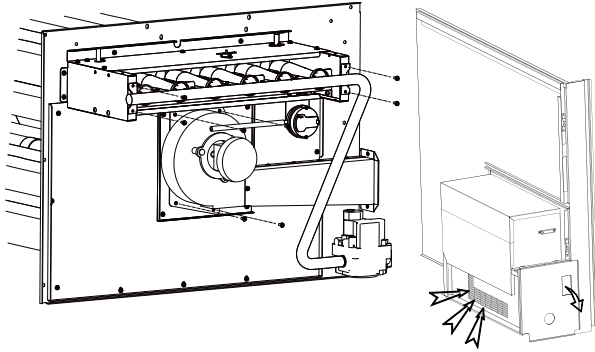

Figure 13. Typical unit gas train configuration



Combustion Airflow Path and Exhaust Path should keep open for heating.

Voltage Imbalance

Three phase electrical power to the unit must meet stringent requirements for the unit to operate properly. Measure each leg (phase-to-phase) of the power supply.

Each reading must fall within the utilization range stamped on the unit nameplate. If any of the readings do not fall within the proper tolerances, notify the power company to correct this situation before operating the unit.

Excessive three phase voltage imbalance between phases will cause motors to overheat and eventually fail. The maximum allowable voltage imbalance is 2 percent.

Measure and record the voltage between phases 1, 2, and 3 and calculate the amount of imbalance as follows:

% Voltage Imbalance = $(100 \times AV - VD) / AV$ where;

- V1, V2, V3 = Line voltage readings
- AV (Average Voltage) = $(V1 + V2 + V3) / 3$
- VD = Line voltage reading that deviates the farthest from the average voltage

Example:

The supply power line voltage readings (V1, V2, V3) are 221, 230, and 227 respectively.:

- AV (Average Voltage) = $(221 + 230 + 227) / 3 = 226$ Avg.
- VD (reading farthest from average) = 221
- % Voltage Imbalance = $(100 + 226 - 221) / 226 = 2.2\%$

The 2.2 percent imbalance in this example exceeds the maximum allowable imbalance of 2.0 percent. This much imbalance between phases can equal as much as a 20 percent current imbalance with a resulting increase in motor winding temperatures that will decrease motor life.

If the voltage imbalance is over 2 percent, notify the proper agencies to correct the voltage problem before operating this equipment.

Electrical Phasing (Three Phase Motors)

The compressor motor(s) and the supply fan motor are internally connected for the proper rotation when the incoming power supply is phased as A, B, C.

Proper electrical supply phasing can be quickly determined and corrected before starting the unit by using an instrument such as an Associated Research Model 45 Phase Sequence Indicator and following the steps below:

WARNING

Hazardous Voltage!

Failure to disconnect power before servicing could result in death or serious injury.

Disconnect all electric power, including remote disconnects before servicing. Follow proper lockout/tagout procedures to ensure the power can not be inadvertently energized. Verify that no power is present with a voltmeter.

1. Turn the field supplied disconnect switch that provides power to the main power terminal block or to the "Line" side of the optional factory mounted disconnect switch to the "Off" position.
2. Connect the phase sequence indicator leads to the terminal block or to the "Line" side of the optional factory mounted disconnect switch as follows:
 - Black (phase A) to L1
 - Brown (phase B) to L2
 - Gray (phase C) to L3
3. Close the field supplied main power disconnect switch or circuit protector switch that provides the supply power to the unit.

WARNING

Live Electrical Components!

Failure to follow all electrical safety precautions when exposed to live electrical components could result in death or serious injury.

When it is necessary to work with live electrical components, have a qualified licensed electrician or other individual who has been properly trained in handling live electrical components perform these tasks.

4. Observe the ABC and CBA phase indicator lights on the face of the sequencer. The ABC indicator light will glow if the phase is ABC. If the CBA indicator light glows, open the disconnect switch or circuit protection switch and reverse any two power wires.
5. Restore the main electrical power and recheck the phasing. If the phasing is correct, open the disconnect switch or circuit protection switch and remove the phase sequence indicator.

Checklist

Use the following checklist in conjunction with the general checklist (“General Unit Requirements,” p. 15) to ensure that the unit is properly installed and ready for operation.

WARNING

Hazardous Voltage!

Failure to disconnect power before servicing could result in death or serious injury.

Disconnect all electric power, including remote disconnects before servicing. Follow proper lockout/tagout procedures to ensure the power can not be inadvertently energized. Verify that no power is present with a voltmeter.

- Check all electrical connections for tightness and “point of termination” accuracy.
- Verify that the condenser airflow is unobstructed.
- Verify that the condenser fan and indoor blower turn freely without rubbing and are properly tightened on the shafts.
- Check the supply fan belts for proper tension and the fan bearings for sufficient lubrication. If the belts require adjustment, or if the bearings need lubricating, refer to the maintenance section of this manual for instructions.
- Verify that a condensate trap is installed and the piping is properly sized and pitched.
- Verify that the correct size and number of filters are in place.
- Inspect the interior of the unit for tools and debris and install all panels in preparation for starting the unit.

External Unit Power Supply

Unit Disconnect Wiring Plan

WARNING

Proper Field Wiring and Grounding Required!

Failure to follow code could result in death or serious injury.

All field wiring **MUST** be performed by qualified personnel. Improperly installed and grounded field wiring poses **FIRE** and **ELECTROCUTION** hazards. To avoid these hazards, you **MUST** follow requirements for field wiring installation and grounding as described in **NEC** and your local/state/national electrical codes.

Important: All phases of this installation must comply with **NATIONAL, STATE, and LOCAL CODES**. In addition to local codes, the installation must comply with **National Electric Code - ANSI/NFPA NO. 70 LATEST REVISION**.

1. Field connections are made by first removing the compressor access panel on the front of the unit. Unscrew the assembly around the outside of the disconnect switch. This assembly is located in the condenser section of the unit.

Both high and low voltage power can be routed through the base or through the front corner post where the disconnect enclosure is mounted. The hole is sized for 1 1/2-in. conduit.
2. If the conduit required for your application is larger than 1 1/2-in., remove the termination plate and connect to the larger hole using field supplied reducing washers.
3. Route the power wires and ground conductor through conduit and into the bottom of a field installed disconnect switch. Connect the power conductors to the lugs provided. Connect the ground wire to the unit ground lug.

Note: Wire size for the length of run should be determined using the circuit ampacity found on the unit nameplate and the N.E.C.
4. Route low voltage (class II), control wiring through hole in base of unit but not through high voltage conduit. Feed control wiring through bushing provided on side panel. Route wires through loose wire ties provided.
5. Tighten the wire ties. Secure the excess wire bundle under the wire ties in the outdoor section. Do not leave excess wire in the electrical enclosure. Use the unit wiring diagram to make the low voltage connections.

Through the Base Gas Utility Option

This section contains the instructions for making field connections to the Through the Base Gas Utility Option.

Field Installed Connections

WARNING

Hazardous Voltage w/Capacitors!

Failure to disconnect power and discharge capacitors before servicing could result in death or serious injury.

Disconnect all electric power, including remote disconnects and discharge all motor start/run capacitors before servicing. Follow proper lockout/tagout procedures to ensure the power cannot be inadvertently energized. Verify with a CAT III or IV voltmeter rated per NFPA 70E that all capacitors have discharged.

WARNING

Proper Field Wiring and Grounding Required!

Failure to follow code could result in death or serious injury.

All field wiring **MUST** be performed by qualified personnel. Improperly installed and grounded field wiring poses **FIRE** and **ELECTROCUTION** hazards. To avoid these hazards, you **MUST** follow requirements for field wiring installation and grounding as described in NEC and your local/state/national electrical codes.

Important: All phases of this installation must comply with NATIONAL, STATE, and LOCAL CODES. In absence of local codes, the installation must conform with American National Standard-Z223.1a- National Fuel Gas Code Latest Revision.

1. Field connections are made by first removing the access panel for the heat section on the front of the unit.

2. The gas piping assembly ships inside this section and includes the shut-off valve, a pressure tap for testing, and the necessary unions for field connection. For through the base access, remove the factory-provided cap from the base pan opening. See Figure 14, p. 22.
3. Route field piping through this hole to the dimension shown in Table 6, p. 22.
4. Place the assembly through the cabinet opening as shown in Figure 14, p. 22 and make the union connection to the field piping and to the gas train. Refer to the "Heating Operation (for Gas Units) - Standard Economizer," p. 25 for startup instructions.

Table 6. Through the base gas piping dimension

Model	Dimension
PRG*090-150	1 3/16-in.

Figure 14. Through the base gas piping installation

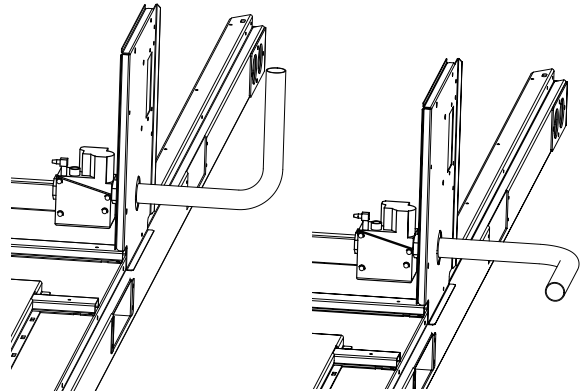

NOTICE

Equipment Damage!

Failure to follow instructions below could result in equipment damage.

Do not run incoming gas pipe in front of gas flue/exhaust outlet.

Pre Start

Verifying Proper Air Flow (Units with Belt Drive Indoor Fan)

Much of the systems performance and reliability is closely associated with, and dependent upon having the proper airflow supplied both to the space that is being conditioned and across the evaporator coil.

The indoor fan speed is changed by opening or closing the adjustable motor sheave.

Before starting the SERVICE TEST, set the minimum position setpoint for the economizer to 0% using the setpoint potentiometer located on the Economizer Control (ECA), if applicable.

WARNING

Risk of Fire or Explosion!

Failure to follow instructions below could cause a fire or explosion which could result in death or serious injury, and equipment damage.

Never test for gas leaks with an open flame. Use a commercially available soap solution made specifically for the detection of leaks to check all connections. A fire or explosion may result causing property damage, personal injury, or loss of life.

Electromechanical Controls – Test Procedure

Fan Test and Minimum Ventilation. Connect the short circuit between R and G.

Connect the short circuit between R and Y1.

Cool 1. Connect the short circuit between R and Y1.

Cool 2. Connect the short circuit between R and Y2.

Heat 1. Connect the short circuit between R and W1.

Heat 2. Connect the short circuit between R and W2.

Start Up

Electromechanical Controls - Sequence Of Operation

These units are offered with electromechanical controls.

Cooling without an Economizer

When the thermostat switch is set to the "Cool" position and the zone temperature rises above the cooling setpoint, the thermostat Y contacts close. The compressor contactor (CC1) coil is energized provided the low pressure control (LPC1), high pressure control (HPC1) and discharge line thermostat (DLT 1) are closed. When the (CC1) contacts close, compressor (CPR1) and both outdoor fan motors (ODM1 and ODM2) start. If the first stage of cooling cannot satisfy the cooling requirement, the thermostat closes Y2. The compressor contactor (CC2) coil is energized provided the low pressure control (LPC2), high pressure control (HPC2) and discharge line thermostat (DLT 2) are closed.

When the (CC2) contacts close, compressor (CPR2) starts.

Evaporator Fan Operation (for Gas Units) - Standard Economizer

Economizer is a field installed accessory. Refer to the following economizer information when the accessory kit is installed.

When the thermostat fan selection switch is set to the "Auto" position, the Ignition Module (IGN) energizes the indoor fan relay (F) approximately 1 second after energizing the compressor contactor coil (CC1) in the cooling mode. In the heating mode, the Ignition Module (IGN) energizes the indoor fan relay (F) coil approximately 45 second after gas ignition. Closing indoor fan relay (F) coil starts the indoor fan motor (IDM). The (IGN) de-energizes the fan relay (F) approximately 80 seconds after the cooling requirement has been satisfied to enhance unit efficiency.

When the heating cycle is terminated, the indoor fan relay (F) coil is de-energized approximately 90 seconds after the heating requirement.

When the thermostat fan selection switch is set to the "On" position, the (IGN) keeps the indoor fan relay coil (F) energized for continuous fan motor operation.

Evaporator Fan Operation (for Cooling Only Units) - Standard Economizer

When the thermostat fan selection switch is set to the "Auto" position, the thermostat energizes the indoor fan relay coil (F) to start the indoor fan motor (IDM). The fan relay (F) de-energizes after the cooling requirement has been satisfied. When the heating cycle is terminated, the indoor fan relay (F) coil is de-energized with heater contactors.

When the thermostat fan selection switch is set to the "On" position, the thermostat keeps the indoor fan relay coil (F) energized for continuous fan motor operation.

Economizer Set-Up - Standard Economizer

Adjusting the minimum position potentiometer located on the unit economizer module (RTEM-EM) sets the required amount of ventilation air.

Ambient temperature is controlling the economizing cycle by sensing the outside air dry bulb temperature. [Table 7, p. 24](#) lists the selectable dry bulb values by potentiometer setting.

Table 7. Potentiometer settings

Potentiometer Setting	Dry Bulb	Enthalpy
A	27 Btu/lb (63 kJ/kg)	73°F (22.8°C)
B	25 Btu/lb (58 kJ/kg)	70°F (21.1°C)
C ^(a)	23 Btu/lb (53 kJ/kg)	67°F (19.4°C)
D	22 Btu/lb (51 kJ/kg)	63°F (17.2°C)
E	19 Btu/lb (44 kJ/kg)	55°F (12.8°C)

^(a) Factory setting

Cooling with an Economizer - Standard Economizer

The economizer is utilized to control the zone temperature providing the outside air conditions are suitable. Outside air is drawn into the unit through modulating dampers.

When cooling is required and economizing is possible, the unit economizer module (RTEM-EM) opens the economizer damper. The RTEM-EM continues to modulate the economizer damper open/closed to keep the mixed air temperature in the 50°F to 55°F range.

The thermostat will close the Y2 contacts to turn on contactor (CC1) if mechanical cooling is required.

If economizing is not possible, the RTEM-EM drives the damper to the minimum position setpoint when the indoor fan relay (F) is energized and allows mechanical cooling operation.

Heating Operation (Units with Electric Heat) - Standard Economizer

When the system switch is set to the "Heat" position and the zone temperature falls below the heating setpoint, the thermostat closes W1 contacts the first stage electric heat contactor (AH or AH and CH) is energized. If the first stage of electric heat cannot satisfy the heating requirement, the thermostat closes W2.

When the W2 contacts close, the second stage electric heat contactor (BH or BH and DH) is energized, if applicable. The thermostat cycles both the first and second stages of heat "On" and "Off" as required to maintain the zone temperature setpoint.

Heating Operation (for Gas Units) - Standard Economizer

When the system switch is set to the "Heat" position and the zone temperature falls below the heating setpoint, the Ignition module (IGN) initiates a heat cycle.

Ignition Module Low, Medium and High Heat

Two-stage (IGN) runs self-check (including verification that the gas valve is de-energized). (IGN) checks the high-limit switches (TC01 and TC01) for normally closed contacts, the pressure switch (PS) for normally open contacts, and the flame rollout (FR) switch for continuity. (IGN) energizes inducer blower on high speed to check pressure switch closure. If the pressure switch is closed, the inducer blower starts a 20 second pre-purge (15 seconds on high speed followed by 5 seconds on low speed).

If the pressure switch (PS) is still open, the inducer blower will continue to be energized on high speed until pressure switch closure.

After pre-purge completes, the (IGN) energizes the first stage of the gas valve, initiates spark for 2 seconds minimum, 7 seconds maximum (ignition trial) and detects flame and de-energizes spark. From this point, a fixed 45 second indoor blower delay on timing starts.

After the indoor blower delay on is completed, the (IGN) energizes the indoor blower. The (IGN) enters a normal operating loop where all inputs are continuously monitored. If the first stage of gas heat cannot satisfy the heating requirement, the thermostat closes W2. The (IGN) energizes the second stage of the gas valve and the second stage of inducer blower.

When the zone thermostat is satisfied, the (IGN) de-energizes the gas valve. The (IGN) senses loss of flame. The (IGN) initiates a 5 second inducer blower post purge and 90 second indoor blower delay off at current speed. The (IGN) de-energizes the inducer blower at the end of the post purge. The (IGN) de-energizes the indoor blower at the end of the selected indoor blower delay off.

Table 8. Ignition module diagnostics

Slow Flash	Normal, call for heat.
Two blinks	System lockout (failure to detect or sustain flame).
Three blinks	Pressure switch problem detected.
Four blinks	High Limit Switch protection device open.
Five blinks	Flame sensed and Gas Valve not energized or flame sensed and no 'W' signal.

Table 8. Ignition module diagnostics (continued)

Six blinks	Flame Rollout Switch open.
Seven blinks	Switch open (W1 and W2 swapped).

Two-Speed Indoor Fan Control

For units equipped with two-speed indoor fan control, standard unit operation for cooling and heating will continue and all unit functions will operate normally, except for the control of the indoor fan speed. All units configured with any type of heating will heat the supply air and space as normal utilizing full speed indoor fan by energizing the appropriate outputs. The two-speed indoor fan unit will only utilize two speeds during the cooling operation modes described below.

Cooling Operation

For cooling operation, the unit will operate at Low Fan Speed during Fan Only, Economizer Only, and the first stage of compressor unit modes by Default. When the unit receives a call for cooling, if the economizer is enabled, the unit will energize the associated Low Speed output and begin to modulate the OA Damper open above minimum position up to 100% as necessary. By default, the supply fan will remain at low speed for the duration of Economizer-Only cooling. If the supply fan is on when the first stage compressor is energized, it will remain energized or energize at low speed for the duration of Cool 1.

When there is a call for Cool 2, the second compressor is energized and the Supply Fan will switch to High Speed.

The unit will stage down compressors for cooling in reverse order that they were staged and the supply fan will follow the unit mode transitions. Once it is determined through normal cooling control that the second compressor is no longer necessary to meet cooling demand, the second compressor will be staged back and the supply fan will switch to Low Speed until the unit stages all cooling off or receives a call for Cool 2 again. Once the Supply Fan is no longer requested ON after a Cooling call is cleared, the Supply Fan will remain energized at Low Speed for 60 seconds as on traditional units.

If the economizer is enabled and is being utilized as the first stage of cooling (Y1 active), if the unit receives a Y2 request, the unit will energize the first compressor and will switch the supply fan to high speed until the Y2 request is cleared.

Low Pressure Cutout

The low pressure cutouts are wired in series with the high pressure cutouts and the temperature discharge limits. If this circuit is open before a compressor is started, the compressor in that circuit will not be allowed to operate.

Anytime this circuit is opened, the compressor in that circuit is turned off immediately.

High Pressure Cutout and Temperature Discharge Limit

The high pressure controls and temperature discharge limit are wired in series between the compressor outputs on the LTB and the compressor contactors. If the high pressure safety or temperature discharge limit opens, the compressor on the affected circuit is turned off.

Heating Operation

Standard unit operation for heating will continue on units equipped with a two-speed indoor fan. During heat mode, all units configured with staged electric or gas heat will heat the supply air and space as normal utilizing full speed indoor fan.

Emergency Stop

This input de-energizes the 24 Vac output from the phase monitor and can be activated by opening a field supplied device.

Compressor Start-Up

1. Attach a set of service gauges onto the suction and discharge gauge ports for each circuit.

See, "Cooling Operation," p. 25 for startup instructions.

Scroll Compressors

- Once each compressor has started, verify that the rotation is correct. If wired correctly the suction pressure should drop and the discharge pressure should rise. If a scroll compressor is rotating backwards, it will not pump and a loud rattling sound can be observed.
- Once each compressor has started, verify that the rotation is correct. If wired correctly the suction pressure should drop and the discharge pressure should rise. If a scroll compressor is rotating backwards, it will not pump and a loud rattling sound can be observed.

Figure 15. Compressor terminal box

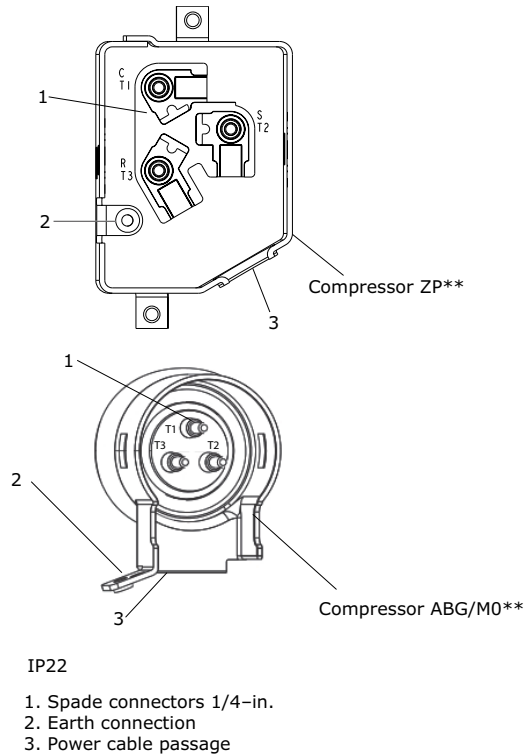

Table 9. Compressor types

Tonnage	208/230V		460V	
	Compressor 1	Compressor 2	Compressor 1	Compressor 2
PRC/G*090	ABG042R	ZP31-TF5	ABG042W	ZP31-TFD
PRC/G*102	ABM051R	ABG42R	ABM051W	ZP31-TFD
PRC/G*120	ABM051R	ZP51-TF5	ABM051W	ZP51-TFD
PRC/G*150	ZP72-TF5	ABM051R	ZP72-TFD	ABM051W

Table 10. POE Oil recharge amount (fl. oz.)

Tonnage	208/230V		460V	
	Compressor 1	Compressor 2	Compressor 1	Compressor 2
PRC/G*090	43	25	43	25
PRC/G*102	43	43	43	43
PRC/G*120	43	42	43	42
PRC/G*150	60	43	60	43

2. After the compressor and condenser fan have started and operated for approximately 30 minutes, observe the operating pressures. Compare the operating pressures to the operating pressure curve..
3. Check system subcooling.
4. Repeat Step 1 through Step 3 for each refrigerant circuit.

5. To stop the SERVICE TEST, turn the main power disconnect switch to the "Off" position or proceed to the next component start-up procedure. Remove electromechanical test mode connections (if applicable).

Heating Start-Up

When starting the unit for the first time or servicing the heaters, it is a good practice to start the heater with the main gas supply turned "Off". Once the ignition system and components have been checked, open the main power disconnect switch to reset the unit.

Final System Set Up

After completing all of the pre-start and startup procedures outlined in the previous sections (i.e., operating the unit in each of its modes through all available stages of cooling and heating), perform these final checks before leaving the unit:

- Inspect the unit for misplaced tools, hardware, and debris.
- Verify that all exterior panels including the control panel doors and condenser grilles are secured in place.
- Close the main disconnect switch or circuit protector switch that provides the supply power to the unit's terminal block or the unit mounted disconnect switch.

Maintenance

WARNING

Electrical Shock, Fire, or Explosion Hazard!

Failure to follow these instructions could result in serious injury, death, or property damage.

- Before servicing, disconnect all electrical power to the furnace.
- When servicing controls, label all wires prior to disconnecting. Reconnect wires correctly.
- Verify proper operation after servicing.

Make sure all personnel are standing clear of the unit before proceeding. The system components will start when the power is applied.

Fan Belt Adjustment-Belt Drive Units

WARNING

Rotating Components!

Failure to disconnect power before servicing could result in rotating components cutting and slashing technician which could result in death or serious injury.

Disconnect all electric power, including remote disconnects before servicing. Follow proper lockout/tagout procedures to ensure the power can not be inadvertently energized.

The fan belts must be inspected periodically to assure proper unit operation. Replacement is necessary if the belts appear frayed or worn. Units with dual belts require a matched set of belts to ensure equal belt length.

When removing or installing the new belts, do not stretch them over the sheaves. Loosen the belts using the belt tension adjustment bolts on the motor mounting base.

Once the new belts are installed, using a Browning or Gates tension gauge (or equivalent), adjust the belt tension as follows:

1. To determine the appropriate belt deflection:
 - a. Measure the center-to-center shaft distance (in inches) between the fan and motor sheaves.

- b. Divide the distance measured in Step 1a by 64; the resulting value represents the amount of belt deflection that corresponds to the proper belt tension.

2. Set the large O-ring on the belt tension gauge at the deflection value determined in Step 1b.
3. Set the small O-ring at zero on the force scale of the gauge plunger.
4. Place the large end of the gauge at the center of the belt span; then depress the gauge plunger until the large O-ring is even with the top of the next belt or even with a straightedge placed across the fan and motor sheaves.
5. Remove the belt tension gauge. The small O-ring now indicates a number other than zero on the plunger's force scale. This number represents the force (in pounds) required to give the needed deflection.
6. Compare the "force" scale reading (Step 5) with the appropriate "force" value listed in the Belt tension table. If the "force" reading is outside the range, readjust the belt tension.

Note: Actual belt deflection "force" must not exceed the maximum "force" value shown in the Belt tension measurement and deflection ranges table.

7. Recheck the belt tension at least twice during the first 2 to 3 days of operation. Belt tension may decrease until the new belts are "run in".

Figure 16. Belt tension gauge

$$\text{Deflection} = \frac{\text{Belt Span (in)}}{64}$$

$$\text{Deflection} = \frac{\text{Belt Span (mm)}}{152}$$

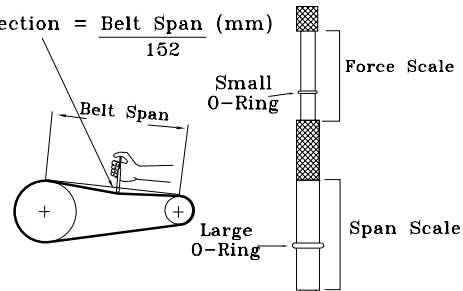

The exhaust gas fan is that lubrication of motor, blower, or fan bearings should not be done, and others should. Check the supply fan belts for proper tension and the fan bearings for sufficient lubrication.

Table 11. Belt tension measurement and deflection ranges (in/lb)

Belts Cross Section	Small P.D Range (in)	Deflection Force (lb)					
		Super Gripbelts (in)		Gripnotch (in)		Steel Cable Gripbelts (in)	
		Min.	Max.	Min.	Max	Min.	Max.
A	3.0–3.6	3.00	4.50	3.87	5.50	3.25	4.00
	3.8–4.8	3.50	5.00	4.50	6.25	3.75	4.75
	5.0–7.0	4.00	5.50	5.00	6.87	4.25	5.25
B	3.4–4.2	4.00	5.50	5.75	8.00	4.50	5.50
	4.4–5.6	5.12	7.12	6.50	9.12	5.75	7.25
	5.8–8.8	6.37	8.75	7.37	10.12	7.00	8.75

Table 12. Belt tension measurement and deflection ranges (mm/kg)

Belts Cross Section	Small P.D Range (mm)	Deflection Force (kg)					
		Super Gripbelts (mm)		Gripnotch (mm)		Steel Cable Gripbelts (mm)	
		Min.	Max.	Min.	Max.	Min.	Max
A	13.3–16.0	13.3	20.0	17.2	24.5	14.5	17.8
	16.9–21.4	15.6	22.2	20.0	27.8	16.7	21.1
	22.0–31.1	17.8	24.5	22.2	30.6	18.9	23.4
B	15.1–18.7	17.8	24.5	25.6	35.6	20.0	24.5
	19.6–24.9	22.8	31.7	28.9	40.6	25.6	32.3
	25.8–39.1	28.4	38.9	32.8	45.0	31.1	38.9

Monthly Maintenance

Before completing the following checks, turn the unit OFF and lock the main power disconnect switch open.

WARNING

Hazardous Voltage!

Failure to disconnect power before servicing could result in death or serious injury.

Disconnect all electric power, including remote disconnects before servicing. Follow proper lockout/tagout procedures to ensure the power can not be inadvertently energized. Verify that no power is present with a voltmeter.

Filters

Inspect the return air filters. Clean or replace them if necessary.

Condensate Overflow Switch

During maintenance, the switch float (black ring) must be checked to ensure free movement up and down.

Cooling Season

- Check the unit's drain pans and condensate piping to ensure that there are no blockages.

- Inspect the evaporator and condenser coils for dirt, bent fins, etc. If the coils appear dirty, clean them according to the instructions described in "Coil Cleaning" later in this section.
- Manually rotate the condenser fans to ensure free movement and check motor bearings for wear. Verify that all of the fan mounting hardware is tight.
- Inspect the F/A-R/A damper hinges and pins to ensure that all moving parts are securely mounted. Keep the blades clean as necessary.

WARNING

Rotating Components!

Failure to disconnect power before servicing could result in rotating components cutting and slashing technician which could result in death or serious injury.

During installation, testing, servicing and troubleshooting of this product it may be necessary to work with live and exposed rotating components. Have a qualified or licensed service individual who has been properly trained in handling exposed rotating components, perform these tasks.

NOTICE

Equipment Damage!

Forcibly turning the motor shaft can damage the gear train and motor beyond repair.

Never turn the motor shaft by hand or with a wrench.

- Verify that all damper linkages move freely; lubricate with white grease, if necessary.
- Check supply fan motor bearings; repair or replace the motor as necessary.
- Check the fan shaft bearings for wear. Replace the bearings as necessary.
- Check the supply fan belt(s). If the belts are frayed or worn, replace them. Refer to the “[Fan Belt Adjustment-Belt Drive Units](#),” p. 28 for belt replacement and adjustments.
- Verify that all wire terminal connections are tight.
- Remove any corrosion present on the exterior surfaces of the unit and repaint these areas.
- Generally inspect the unit for unusual conditions (e.g., loose access panels, leaking piping connections, etc.)
- Make sure that all retaining screws are reinstalled in the unit access panels once these checks are complete.
- With the unit running, check and record the following:
 - ambient temperature
 - compressor oil level (each circuit)
 - compressor suction and discharge pressures (each circuit)
 - superheat and subcooling (each circuit)

Record this data on an “operator’s maintenance log” like the one shown in Sample maintenance log table in Final Process Section. If the operating pressures indicate a refrigerant shortage, measure the system superheat and system subcooling. For guidelines, refer to “[Compressor Start-Up](#),” p. .

Important: *Do not release refrigerant to the atmosphere! If adding or removing refrigerant is required, the service technician must comply with all federal, state and local laws. Refer to general service bulletin MSCU-SB-1 (latest edition).*

Heating Season

- Inspect the unit’s air filters. If necessary, clean or replace them.
- Check supply fan motor bearings; repair or replace the motor as necessary.
- Inspect both the main unit control panel and heat section control box for loose electrical components and terminal connections, as well as damaged wire insulation. Make any necessary repairs.
- Verify that the electric heat system operates properly.

Coil Cleaning

Regular coil maintenance, including annual cleaning enhances the unit’s operating efficiency by minimizing the following:

- Compressor head pressure and amperage draw
- Evaporator water carryover
- Fan brake horsepower
- Static pressure losses
- Airflow reduction

At least once each year, or more often if the unit is located in a “dirty” environment, clean the condenser coils using the instructions outlined below. Be sure to follow these instructions as closely as possible to avoid damaging the coils.

WARNING

Hazardous Chemicals!

Failure to follow this safety precaution could result in death or serious injury. Coil cleaning agents can be either acidic or highly alkaline and can burn severely if contact with skin or eyes occurs.

Handle chemical carefully and avoid contact with skin. ALWAYS wear Personal Protective Equipment (PPE) including goggles or face shield, chemical resistant gloves, boots, apron or suit as required. For personal safety refer to the cleaning agent manufacturer’s Materials Safety Data Sheet and follow all recommended safe handling practices.

Microchannel (MCHE) Coils

NOTICE

Coil Damage!

Failure to follow instructions below could result in coil damage.

DO NOT use any detergents with microchannel condenser coils.

Use pressurized water or air ONLY, with pressure no greater than 600psi.

For additional information regarding the proper microchannel coil cleaning procedure, refer to RT-SVB83*-EN

Due to the soft material and thin walls of the MCHE coils, the traditional field maintenance method recommended for Round Tube Plate Fin (RTPF) coils does not apply to microchannel coils. Moreover, chemical cleaners are a risk factor to MCHE due to the material of the coil. The manufacturer does not recommend the use of chemical cleaners to clean microchannel coils. Using chemical cleaners could lead to warranty claims being further evaluated for validity and failure analysis.

The recommended cleaning method for microchannel condenser coils is pressurized water or air with a non-pinpoint nozzle and an ECU of at least 180 with pressure

no greater than 600 psi. To minimize the risk of coil damage, approach the cleaning of the coil with the pressure washer aimed perpendicular to the face of the coil during cleaning. Optimum clearance between the sprayer nozzle and the microchannel coil is 1”–3”.

Final Process

For future reference, record the unit data below in the blanks provided.

Table 13. Unit data log

Complete Unit Model Number	
Unit Serial Number	
Wiring Diagram Numbers (from unit control panel)	
-schematic(s)	
-connections	
Network ID	

Troubleshooting

WARNING

Hazardous Service Procedures!

Failure to follow all precautions in this manual and on the tags, stickers, and labels could result in death or serious injury.

Technicians, in order to protect themselves from potential electrical, mechanical, and chemical hazards, **MUST** follow precautions in this manual and on the tags, stickers, and labels, as well as the following instructions: Unless specified otherwise, disconnect all electrical power including remote disconnect and discharge all energy storing devices such as capacitors before servicing. Follow proper lockout/tagout procedures to ensure the power can not be inadvertently energized. When necessary to work with live electrical components, have a qualified licensed electrician or other individual who has been trained in handling live electrical components perform these tasks.

Standard Troubleshooting

Ignition Module

The Ignition Module (IGN) has the ability to provide the service personnel with some unit diagnostics and system status information.

Before turning the main power disconnect switch “Off”, follow the steps below to check the IGN.

To prevent injury or death from electrocution, it is the responsibility of the technician to recognize this hazard and use extreme care when performing service procedures with the electrical power energized.

1. Verify LED on face of the phase monitor is green. If LED is red, correct supply power fault.
2. Verify that the LED on the IGN is burning continuously. If the LED is lit, go to Step 5.
3. Verify that the Digital Display on the mainboard is displaying “-”. If the Digital Display is right, go to Step 5.
4. If the LED is not lit, verify that 24 Vac is present between R and C. If the LED is not lit and 24 Vac is present replace the IGN. If the Digital Display is not lit and 24 Vac is present replace the mainboard. If 24 Vac is not present, check fuse 2 on the mainboard and check transformer (TNS1). Proceed to Step 5 if necessary.
5. If no failures are indicated, use the TEST mode procedures described in the “Unit Start-Up” section or thermostat to start the unit. This procedure will allow you to check all of the external controls (relays, contactors, etc) and the IGN.
6. Test the system through all of the available modes, and

verify operation of all outputs, controls, and modes.

Refer to the sequence of operations for each mode, to assist in verifying proper operation. Make the necessary repairs and proceed to Step 6 and Step 7.

7. If no abnormal operating conditions appear in the test mode, exit the test mode by turning the power “Off” at the main power disconnect switch and removing the test mode connections.

Failures

Heating Failure

Verify Heat Failure by Ignition Module (IGN) LED indicator:

Slow Flash: Normal, Heat Call

Fast Flash: Error Code:

Flash: System Lockout

1 Flash: Pressure Switch Fail

2 Flash: Primary Limit Open

3 Flash: Flame detected when gas valve is not open

4 Flash: Flame Rollout Open

5 Flash: W2 signal but no W1 signal

6 flash :Thermostat miswired (W1 and W2 swapped)

Simultaneous Heat and Cool Failure

Emergency Stop is activated.

To Clear an Alarm

Once the alarm has been identified and the cause has been removed (for example, replaced faulty sensor), the alarm can be cleared from the display.

Resetting Cooling and Heating Lockouts

Cooling Failures and Heating Lockouts are reset in an identical manner.

Method 1 section explains resetting the system from the space; Method 2 section explains resetting the system at the unit.

Note: Before resetting Cooling Failures and Heating Lockouts check the Failure Status Diagnostics by the methods previously explained. Diagnostics will be lost when the power to the unit is disconnected.

Method 1

To reset the system from the space, turn the “Mode” selection switch at the thermostat to the “Off” position. After approximately 30 seconds, turn the “Mode” selection switch to the desired mode, i.e. Heat, Cool or Auto.

Troubleshooting

Method 2

To reset the system at the unit, cycle the unit power by turning the disconnect switch “Off” and then “On”.

Table 15. Troubleshooting chart

Symptom	Possible Cause	Remedy
Unit will not run	Power off or loose electrical connection	Check for correct voltage at compressor contactor in control box
	Thermostat out of calibration-set too high	Reset
	Failed contactor	Check for 24 volts at contactor coil - replace if contacts are open
	Blown fuses	Replace fuses
	Transformer defective	Check wiring - replace transformer
	Interconnecting low voltage wiring damaged	Replace thermostat wiring
Condenser fan runs, compressor doesn't	Run or start capacitor failed (single phase only)	Replace
	Loose connection	Check for correct voltage at compressor - check and tighten all connection
	Compressor stuck, grounded or open motor winding open internal overload	Wait at least 2 hours for overload to reset. If still open, replace the compressor.
	Low voltage condition	Determine cause and correct. At compressor terminals, voltages must be within 10% of rating plate volts when unit is operating.
Insufficient cooling	Improperly sized unit	Recalculate load
	Improper airflow	Check - should be approximately 400 CFM per ton.
	Incorrect refrigerant charge	Charge per procedure attached to unit service panel.
	Air, non-condensable or moisture in system	Recover refrigerant, evacuate & recharge, add filter drier
	Incorrect voltage	Determine cause and correct. At compressor terminals, voltages must be within 10% of rating plate volts when unit is operating.
Compressor short cycles	Incorrect voltage	At compressor terminals, voltage must be $\pm 10\%$ or nameplate marking when unit is operating.
	Defective overload protector	Replace - check for correct voltage
	Refrigerant undercharge	Add refrigerant
Compressor operates continuously	Dirty air filter	Replace filter
	Unit undersized for load	Decrease load or increase unit size
	Thermostat temperature set too low	Reset thermostat
	Low refrigerant charge	Locate leak, repair, and recharge
	Air in system	Recover refrigerant, evacuate system, and recharge
	Outdoor coil dirty or restricted	Clean coil or remove restriction
Registers sweat	Low evaporator airflow	Increase speed of blower or reduce restriction - replace air filter
High head-low vapor pressure	Restriction in liquid line, expansion device or filter drier	Remove or replace defective component
	Flow check piston size too small	Change to correct size piston
	Incorrect capillary tubes	Change coil assembly
	TXV does not open	Replace TXV
High head-high or normal vapor pressure - Cooling mode	Dirty condenser coil	Clean coil
	Refrigerant overcharge	Correct system charge
	Condenser fan not running	Repair or replace
	Air or non-condensable in system	Recover refrigerant, evacuate & recharge
Low head-high vapor pressures	Defective compressor valves	Replace compressor
	Incorrect capillary tubes	Replace coil assembly

Table 15. Troubleshooting chart (continued)

Symptom	Possible Cause	Remedy
Low vapor - cool compressor - iced evaporator coil	Low evaporator airflow	Increase speed of blower or reduce restriction - replace air filter
	Moisture in system	Recover refrigerant - evacuate & recharge - add filter drier
High vapor pressure	Excessive load	Recheck load calculation
	Defective compressor	Replace
Fluctuating head and vapor pressure	TXV hunting	Check TXV bulb clamp - check air distribution on coil - replace TXV
	Air or non-condensable in system	Recover refrigerant - evacuate and recharge
Gurgle or pulsing noise at expansion device or liquid line	Air or non-condensable in system	Recover refrigerant - evacuate and recharge
Circulating air blower and inducer run continuously, compressor will not start	Manual reset overtemperature control tripped	Reset or replace
	Wire loose in limit circuit	Check wiring
Burners will not ignite	Water in gas line	Drain. Install drip leg.
	No power to furnace	Check power supply fuses, wiring or circuit breaker.
	No 24 volts power supply to control circuit	Check transformer.
	Miswired or loose connections	Check all wiring and wire nut connections
	Misaligned spark electrodes	Check flame ignition and sense electrode positioning. Adjust as necessary
	No gas at main burners	Check gas line for air. Purge as necessary. NOTE: After purging gas line of air, wait at least 5 minutes for any gas to dissipate before attempting to light unit. Check gas valve.
Inadequate heating	Dirty air filter	Clean or replace filter as necessary
	Gas input to furnace too low	Check gas pressure at manifold with that on unit nameplate
	Unit undersized for application	Replace with proper unit or add additional unit
	Restricted airflow	Clean or replace filter, remove any restriction
	Limit switch cycles main burners	Check rotation of blower, temperature rise of unit. Adjust as necessary.
Poor flame characteristics	Incomplete combustion results in: Aldehyde odors, carbon monoxide, sooting flame, floating flame	Tighten all screws around burner compartment
		Cracked heat exchanger. Replace as necessary.
		Unit over-fired. Reduce input (change orifices or adjust gas line or manifold pressure).
		Check burner alignment
		Inspect heat exchanger for blockage. Clean as necessary.
Both condenser fan and compressor startup and shutdown frequently (about three minutes per cycle)	Abnormal high discharge pressure caused the high pressure switch act	Reference to the remedy of 'High head-high or normal vapor pressure-cooling mode'.

Horizontal Duct Conversion instruction

⚠ WARNING

Hazardous Voltage w/Capacitors!
Disconnect all electric power, including remote disconnects and discharge all motor start/run capacitors before servicing. Follow proper lockout/tagout procedures to ensure the power cannot be inadvertently energized. For variable frequency drives or other energy storing components provided by Oxbox or others, refer to the appropriate manufacturer's literature for allowable waiting periods for discharge of capacitors. Verify with an appropriate voltmeter that all capacitors have discharged. Failure to disconnect power and discharge capacitors before servicing could result in death or serious injury.

1. Remove the return and supply duct cover panels from the unit as shown in Figure 1 . These panels should not be discarded.

Figure 1. Remove return and supply duct cover panels

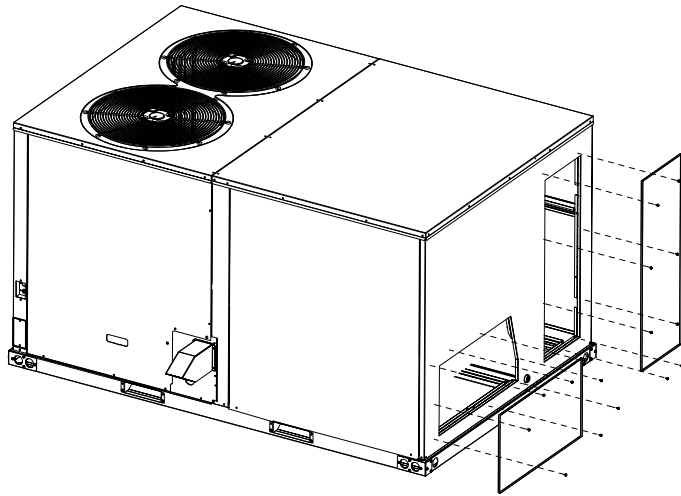

1. Install the return and supply duct cover panel to cover up the second return and supply opening in the base as shown in Figure 2. The return duct cover panel is the one previously removed.

Figure 2. Install return and supply duct cover panels

