

# INSTALLATION INSTRUCTIONS

## FOR 80+ COMMUNICATING, UPFLOW/HORIZONTAL, ULTRA LOW NOX GAS FURNACES WITH CONSTANT CFM/PWM BLOWER.

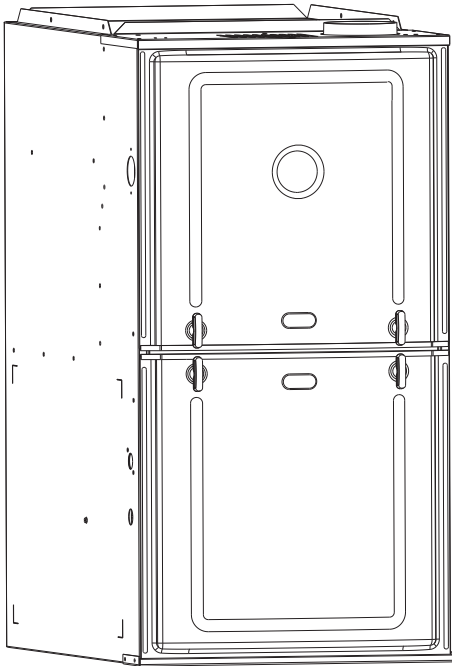

**RECOGNIZE THIS SYMBOL AS AN INDICATION OF IMPORTANT SAFETY INFORMATION!**

### ▲ WARNING

**IF THE INFORMATION IN THESE INSTRUCTIONS IS NOT FOLLOWED EXACTLY, A FIRE OR EXPLOSION MAY RESULT CAUSING PROPERTY DAMAGE, PERSONAL INJURY OR DEATH.**

### ▲ WARNING

**THESE INSTRUCTIONS ARE INTENDED AS AN AID TO QUALIFIED SERVICE PERSONNEL FOR PROPER INSTALLATION, ADJUSTMENT AND OPERATION OF THIS UNIT. READ THESE INSTRUCTIONS THOROUGHLY BEFORE ATTEMPTING INSTALLATION OR OPERATION. FAILURE TO FOLLOW THESE INSTRUCTIONS MAY RESULT IN IMPROPER INSTALLATION, ADJUSTMENT, SERVICE OR MAINTENANCE, POSSIBLY RESULTING IN FIRE, ELECTRICAL SHOCK, CARBON MONOXIDE POISONING, EXPLOSION, PROPERTY DAMAGE, PERSONAL INJURY OR DEATH.**

### ▲ WARNING

**CARBON-MONOXIDE POISONING HAZARD  
FAILURE TO FOLLOW INSTRUCTIONS COULD RESULT IN SEVERE PERSONAL INJURY OR DEATH DUE TO CARBON-MONOXIDE POISONING, IF COMBUSTION PRODUCTS INFILTRATE INTO THE BUILDING.**

**CHECK THAT ALL OPENINGS IN THE OUTSIDE WALL AROUND THE VENT (AND AIR INTAKE) PIPE(S) ARE SEALED TO PREVENT INFILTRATION OF COMBUSTION PRODUCTS INTO THE BUILDING.**

**CHECK THAT FURNACE VENT (AND AIR INTAKE) TERMINAL(S) ARE NOT OBSTRUCTED IN ANY WAY DURING ALL SEASONS.**

**AHRI CERTIFIED®**  
www.ahridirectory.org

Residential Furnaces  
DOE 10 CFR Part 430



### ▲ WARNING

- Do not store or use gasoline or other flammable vapors and liquids, or other combustible materials in the vicinity of this or any other appliance.
- **WHAT TO DO IF YOU SMELL GAS**
  - Do not try to light any appliance.
  - Do not touch any electrical switch; do not use any phone in your building.
  - Immediately call your gas supplier from a neighbor's phone. Follow the gas supplier's instructions.
  - If you cannot reach your gas supplier, call the fire department.
  - Do not return to your home until authorized by the gas supplier or fire department.
- **DO NOT RELY ON SMELL ALONE TO DETECT LEAKS. DUE TO VARIOUS FACTORS, YOU MAY NOT BE ABLE TO SMELL FUEL GASES.**
  - U.L. and/or C.S.A. recognized fuel gas and CO (carbon monoxide) detectors are recommended in all applications, and their installation should be in accordance with the manufacturer's recommendations and/or local laws, rules, regulations, or customs.
- Improper installation, adjustment, alteration, service or maintenance can cause injury property damage or death. Refer to this manual. Installation and service must be performed by a qualified installer, service agency or the gas supplier. In the commonwealth of Massachusetts, installation must be performed by a licensed plumber or gas fitter for appropriate fuel.

**DO NOT DESTROY THIS MANUAL. PLEASE READ CAREFULLY AND KEEP IN A SAFE PLACE FOR FUTURE REFERENCE BY A SERVICEMAN.**

# TABLE OF CONTENTS

<b>1</b>	<b>TABLE OF CONTENTS</b>	<b>2</b>	<b>10</b>	<b>STARTUP PROCEDURES</b>	<b>33</b>
<b>2</b>	<b>GENERAL INFORMATION</b>	<b>3</b>	Sequence of Operation	33	
	Receiving	4	To Start Furnace	33	
	Material Information	4	To Shut Down Furnace	33	
	Efficiency Testing Notice	4	80+ ULN Sequence of Operations	33	
	Checklist	5	<b>11</b>	<b>INTEGRATED FURNACE CONTROL</b>	<b>34</b>
<b>3</b>	<b>SAFETY INFORMATION</b>	<b>6</b>	Humidification/Dehumidification	34	
	Warnings	6	Supply & outdoor air temperature sensors	37	
	Important Information About Efficiency and Quality	7	Auxiliary inputs	39	
<b>4</b>	<b>LOCATION REQUIREMENTS</b>	<b>8</b>	<b>12</b>	<b>TIMING DIAGRAM</b>	<b>40</b>
	Site Selection	8	<b>13</b>	<b>FIELD SELECTIONS &amp; ADJUSTMENTS</b>	<b>41</b>
	Clearance – Accessibility	8	Field adjustments	41	
	Upflow/Horizontal Dimensions and Clearance Table	10	<b>14</b>	<b>FAULT CODES</b>	<b>42</b>
<b>5</b>	<b>DUCTING</b>	<b>11</b>	Diagnostics and fault codes	42	
	Upflow Installations	11	Dual Faults Displayed	42	
	Horizontal Installations	13	<b>15</b>	<b>1-STAGE LOCKOUT</b>	<b>43</b>
<b>6</b>	<b>COMBUSTION AND VENTILATION AIR</b>	<b>14</b>	Lockout	43	
	Combustion Air Requirements	14	<b>16</b>	<b>FIELD SELECTIONS &amp; ADJUSTMENTS</b>	<b>53</b>
	Overtemperature Safety Switches	14	Field selections - Dipswitches	53	
	Furnace Located in Unconfined Space	15	Manual Fault clear; SW4	54	
	Furnace Located in Confined Space	15	Fault recall	54	
	Combustion Air from Attic	17	Flame status L.E.D. (Amber)	54	
	Venting	18	Adjusting or checking furnace input	54	
	“B-1” Vertical Venting	18	Setting input rate	55	
	Special Vent Systems (SVS)	19	<b>17</b>	<b>HIGH ALTITUDE</b>	<b>56</b>
	Existing Vent Systems	20	<b>17</b>	<b>AIRFLOW</b>	<b>57</b>
<b>7</b>	<b>GAS SUPPLY</b>	<b>21</b>	<b>19</b>	<b>SAFETY FEATURES</b>	<b>58</b>
	Gas Supply and Piping	21	Limit Control	58	
	Gas Piping	22	Over Temperature Safety Switches	58	
	Gas Pressure	23	Burner Assembly	58	
	Gas Valve	23	Pressure Switches	58	
	Setting Gas Pressure	24	<b>20</b>	<b>MAINTENANCE</b>	<b>59</b>
	Supply Gas Pressure Measurement	24	<b>21</b>	<b>FILTERS</b>	<b>59</b>
	Manifold Gas Pressure Measurement	24	<b>22</b>	<b>VENTURI AIR INLET FILTER</b>	<b>59</b>
<b>8</b>	<b>ELECTRICAL WIRING</b>	<b>25</b>	<b>23</b>	<b>LUBRICATION</b>	<b>59</b>
	Electrical Connections	25	<b>24</b>	<b>SYSTEM OPERATION INFORMATION</b>	<b>60</b>
	Relocating the Electrical Connection	25	<b>25</b>	<b>ANNUAL INSPECTION</b>	<b>60</b>
	Thermostat	26	<b>26</b>	<b>REPLACEMENT PARTS</b>	<b>60</b>
<b>9</b>	<b>ACCESSORIES</b>	<b>31</b>	<b>27</b>	<b>DIAGNOSTICS</b>	<b>60</b>
	Field Installed Option Accessories	31	<b>28</b>	<b>WIRING DIAGRAM</b>	<b>60</b>
	Electronic Air Cleaner	31			
	Humidifier	31			
	Filters	31			

**IMPORTANT:** TO INSURE PROPER INSTALLATION AND OPERATION OF THIS PRODUCT, COMPLETELY READ ALL INSTRUCTIONS PRIOR TO ATTEMPTING TO ASSEMBLE, INSTALL, OPERATE, MAINTAIN OR REPAIR THIS PRODUCT. UPON UNPACKING OF THE FURNACE, INSPECT ALL PARTS FOR DAMAGE PRIOR TO INSTALLATION AND START-UP.

# GENERAL INFORMATION

**NOTE:** A heat loss calculation should be performed to properly determine the required furnace BTU size for the structure. Also, the duct must be properly designed and installed for proper airflow. Existing ductwork must be inspected for proper size and to make sure that it is properly sealed. Proper airflow is necessary for both user comfort and equipment performance.

**Verify that the data tags on the carton specify the furnace model number that was ordered from the distributor and are correct for the installation. If not, return the unit without opening the carton. If the model number is correct, open the carton and verify that the furnace rating label specifies the same furnace model number that is specified on the carton label. If the model numbers do not match, return the furnace to the distributor.**

**IMPORTANT:** Proper application, installation and maintenance of this furnace and system is a must if consumers are to receive the full benefits for which they have paid.

The Single Stage Variable Speed Ultra Low NOx series furnaces

are design certified by CSA for use with natural gas as follows:

As a Category I furnace, it may be vented vertically with type B-1 vent pipe and also may be common vented as described in these instructions.

This furnace should be installed in accordance with the American National Standard Z223.1 - latest edition booklet entitled "National Fuel Gas Code" (NFPA 54), and the requirements or codes of the local utility or other authority having jurisdiction including local plumbing or waste water codes.

With the introduction of higher efficiency furnaces, special attention must be paid to the venting system. Only listed venting systems may be used as stated in the installation instructions and the National Fuel Gas Code, ANSI Z223.1 (NFPA 54),.

Since furnace technology and venting requirements are changing, awareness of local, state, and federal codes and industry changes is imperative.

**FIGURE 1**  
FURNACE COMPONENTS

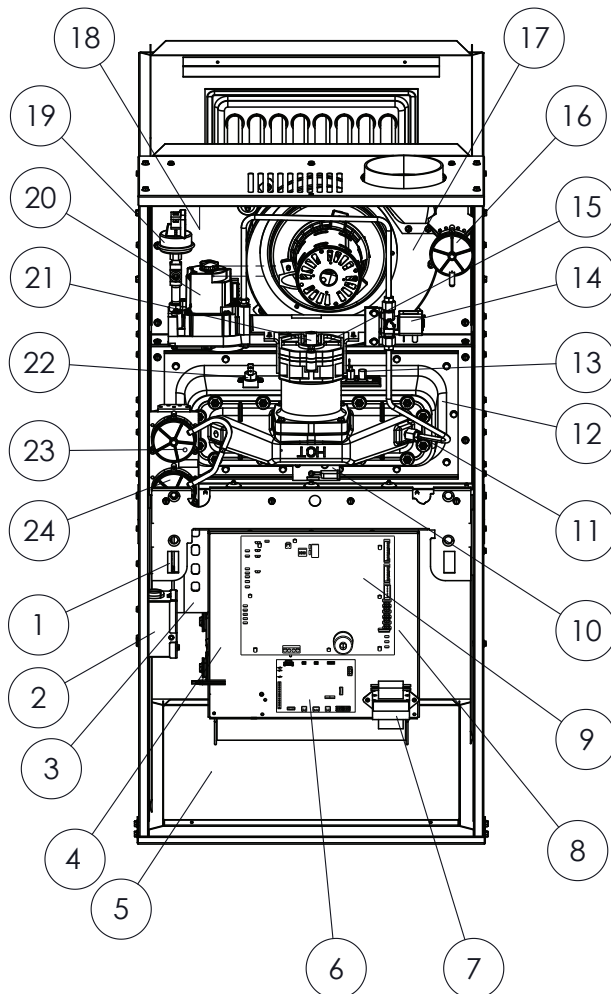

ITEM

NO.      DESCRIPTION

1. DOOR SWITCH
2. JUNCTION BOX
3. CONSTANT CFM MOTOR
4. CONTROL MOUNTING PLATE
5. SOLID METAL BASE PAN
6. INTERFACE CONTROL BOARD
7. TRANSFORMER
8. LOW VOLTAGE TERMINALS
9. FURNACE CONTROL
10. FLAME LED BOARD (ALT FLAME LIGHT)
11. PILOT ORIFICE
12. BURNER ASSEMBLY
13. IGNITOR/FLAME SENSE
14. PILOT SOLENOID (PLSD)
15. COMBUSTION AIR INLET / FILTER (if equipped)
16. AIR INLET PRESSURE SWITCH (AIPS)
17. INDUCED DRAFT BLOWER
18. MAIN LIMIT
19. GAS PRESSURE SWITCH
20. GAS VALVE W/PILOT
21. ORIFICE
22. OVER-TEMPERATURE SWITCH (X3)
23. COMBUSTION PRESSURE SWITCH IGNITION
24. PRESSURE SWITCH

ST-A1332-04

# GENERAL INFORMATION (cont.)

Install this furnace in accordance with the American National Standard Z223.1 – latest edition entitled “National Fuel Gas Code” (NFPA54) and requirements or codes of the local utilities or other authorities having jurisdiction. This is available from the following:

National Fire Protection Association, Inc.  
Batterymarch Park  
Quincy, MA 02269

## RECEIVING

Immediately upon receipt, all cartons and contents should be inspected for transit damage. Units with damaged cartons should be opened immediately. If damage is found, it should be noted on the delivery papers, and a damage claim filed with the last carrier.

- After unit has been delivered to job site, remove carton taking care not to damage unit.
- Check the unit rating plate for unit size, electric heat, coil, voltage, phase, etc. to be sure equipment matches what is required for the job specification.
- Read the entire instructions before starting the installation.
- Some building codes require extra cabinet insulation and gasketing when unit is installed in attic applications.
- If installed in an unconditioned space, apply caulking around the power wires, control wires, refrigerant tubing and condensate line where they enter the cabinet. Seal the power wires on the inside where they exit conduit opening. Caulking is required to prevent air leakage into and condensate from forming inside the unit, control box, and on electrical controls.
- Install the unit in such a way as to allow necessary access to the coil/filter rack and blower/control compartment.
- Install the unit in accordance with any local code which may apply and the national codes. Latest editions are available from: “National Fire Protection Association, Inc., Batterymarch Park, Quincy, MA 02269.” These publications are:
  - ANSI/NFPA No. 70-(Latest Edition) National Electrical Code.
  - NFPA90A Installation of Air Conditioning and Ventilating Systems.
  - NFPA90B Installation of warm air heating and air conditioning systems.
- The equipment has been evaluated in accordance with the Code of Federal Regulations, Chapter XX, Part 3280.

## MATERIAL INFORMATION

All manufacturer products meet current Federal OSHA Guidelines for safety. Most consumers are aware that products present safety and health risks, when improperly used, handled and maintained. More details are available at the Website for OSHA (Occupational Safety and Health Administration) at [www.osha.gov](http://www.osha.gov) and the State of California’s Proposition 65 Website at [www.P65Warnings.ca.gov](http://www.P65Warnings.ca.gov).

## EFFICIENCY TESTING NOTICE

For purposes of verifying or testing efficiency ratings, the test procedure in Title 10 Appendix N to Subpart B of Part 430 (Uniform Test Method for Measuring the Energy Consumption of Furnaces and Boilers) and the clarifying positions provided in the AHRI Operations Manual for Residential Furnaces that were applicable at the date of manufacture should be used for test set up and performance.

**Installation Instructions remain with the furnace as a reference guide to the servicing contractor. We recommend that performance and installation data be recorded for future reference on this sheet to meet service and warranty obligations so that job site information is available when required.**

## INSTALLATION CHECKLIST

REFER TO INSTALLATION INSTRUCTIONS

### GAS SUPPLY

- \_\_\_\_\_ Correct pipe size (record size)
- \_\_\_\_\_ No Gas Leaks in main line or pilot tubing
- \_\_\_\_\_ Correct supply pressure (during furnace operation) (record pressure)
- \_\_\_\_\_ Manifold pressure (record pressure)
- \_\_\_\_\_ Heating Value of Fuel
- \_\_\_\_\_ Calculated BTU Input
- \_\_\_\_\_ Orifice Size
- \_\_\_\_\_ Co2

### ELECTRICAL

- \_\_\_\_\_ 115 V.A.C. supply (Dedicated Circuit) (record voltage)
- \_\_\_\_\_ Polarity observed
- \_\_\_\_\_ Furnace properly grounded
- \_\_\_\_\_ Correct wire size (record type and gauge)

### FURNACE INSTALLATION

- \_\_\_\_\_ Correct clearance to combustibles (record clearance)
- \_\_\_\_\_ Correct clearance for service (at front) (record clearance)

### DUCT STATIC PRESSURE

- \_\_\_\_\_/\_\_\_\_ Delta in. w.c. on heating speed (record static pressure before/after AC Coil)
- \_\_\_\_\_/\_\_\_\_ Delta in. w.c. on cooling speed (record static pressure before/after AC Coil)
- \_\_\_\_\_/\_\_\_\_ Air temperature rise in heat (record speed tap/air temperature rise)
- \_\_\_\_\_/\_\_\_\_ Air temperature rise in cool (record speed tap/air temperature rise)

### VENTING

- \_\_\_\_\_ Correct vent pipe diameter and length (according to NFGC tables) \_\_\_\_\_ Vent connection size / Configuration
- \_\_\_\_\_ Correct venting material (according to NFGC tables)
- \_\_\_\_\_ Correct lining for masonry chimneys
- \_\_\_\_\_ Adequate clearance from combustibles
- \_\_\_\_\_ Proper negative pressure reading in the vent
- \_\_\_\_\_ Vent pipe secured to induced draft blower housing

### COMBUSTION AIR (according to NFGC)

- \_\_\_\_\_ Proper source of combustion air
- \_\_\_\_\_ Correct combustion air opening size

Use this space to sketch the vent configuration of your installation

- Upflow
- Hz Right
- Hz Left

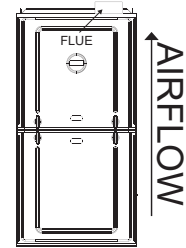

ST-A1252-34

Checklist

# SAFETY INFORMATION

## WARNINGS

### WARNING

DO NOT INSTALL THIS FURNACE IN A MOBILE HOME! THIS FURNACE IS NOT APPROVED FOR INSTALLATION IN A MOBILE HOME. DOING SO COULD CAUSE FIRE, PROPERTY DAMAGE, PERSONAL INJURY OR DEATH.

### WARNING

INSTALL THIS FURNACE ONLY IN A LOCATION AND POSITION AS SPECIFIED IN THE LOCATION REQUIREMENTS AND CONSIDERATIONS SECTION OF THESE INSTRUCTIONS.

### WARNING

IMPROPER INSTALLATION CAN RESULT IN UNSATISFACTORY OPERATION AND/OR DANGEROUS CONDITIONS AND ARE NOT COVERED BY THE MANUFACTURER'S WARRANTY.

### WARNING

DO NOT BYPASS, JUMPER, OR REMOVE ANY SAFETY SWITCH FROM THE FURNACE CONTROL CIRCUIT. IF A SAFETY SWITCH CAUSES THE FURNACE TO SHUT DOWN OR OPERATE INTERMITTENTLY, IT IS AN INDICATION OF A POTENTIAL SAFETY HAZARD THAT MUST BE ADDRESSED BY A QUALIFIED TECHNICIAN, SERVICE AGENCY OR THE GAS SUPPLIER. DO NOT RESET SAFETY CONTROLS WITHOUT CORRECTIVE ACTION AND/OR VERIFICATION OF PROPER SAFE OPERATION BY A QUALIFIED INSTALLER, SERVICE AGENCY OR THE GAS SUPPLIER.

REPLACE ANY SAFETY CONTROL COMPONENT ONLY WITH IDENTICAL OEM REPLACEMENT PARTS. WHEN A NEW SAFETY SWITCH IS INSTALLED, IT MUST BE TESTED FOR A MINIMUM OF 15 MINUTES WITH THE FURNACE OPERATING AT MAXIMUM INPUT RATE AND WITH BOTH BLOWER AND BURNER DOOR INSTALLED. IF THE FURNACE IS INSTALLED IN A CLOSET, THE CLOSET DOOR MUST ALSO BE CLOSED FOR THIS TEST. REPEAT THE TEST AT THE MINIMUM INPUT RATE IF THE FURNACE IS A MULTI-STAGE FURNACE.

### WARNING

USE ONLY WITH THE TYPE OF GAS APPROVED FOR THIS FURNACE. REFER TO THE FURNACE RATING PLATE.

### WARNING

NEVER TEST FOR GAS LEAKS WITH AN OPEN FLAME. USE A COMMERCIALLY AVAILABLE SOAP SOLUTION MADE SPECIFICALLY FOR THE DETECTION OF LEAKS TO CHECK ALL CONNECTIONS, AS SPECIFIED IN GAS SUPPLY AND PIPING SECTION OF THESE INSTRUCTIONS.

### WARNING

COMBUSTION AND VENTILATION AIR MUST BE PROVIDED TO THE FURNACE AS REQUIRED BY THE NATIONAL FUEL-GAS CODE (U.S.) AND CSA B149.1 (CANADA) AND THE COMBUSTION AND VENTILATION AIR SECTION OF THESE INSTRUCTIONS.

### WARNING

COMBUSTION PRODUCTS MUST BE DISCHARGED OUTDOORS. CONNECT THIS FURNACE TO AN APPROVED VENT SYSTEM ONLY, AS SPECIFIED IN THE VENT PIPE INSTALLATION SECTION OF THESE INSTRUCTIONS.

### WARNING

WHEN A FURNACE IS INSTALLED SO THAT SUPPLY DUCTS CARRY AIR CIRCULATED BY THE FURNACE TO AREAS OUTSIDE THE SPACE CONTAINING THE FURNACE, THE RETURN AIR SHALL ALSO BE HANDLED BY DUCT(S) SEALED TO THE FURNACE CASING AND TERMINATING OUTSIDE THE SPACE CONTAINING THE FURNACE.

### WARNING

WHENEVER THE FACTORY RETURN-AIR CONNECTION IS NOT USED IT MUST BE SEALED. A SOLID METAL BASE PLATE MUST BE INSTALLED AND SEALED. FACTORY BASE PLATES ARE AVAILABLE AS ACCESSORY ITEMS. (PART NUMBERS ARE LISTED IN THE SPEC SHEET FOR THE FURNACE.) FAILURE TO INSTALL AND SEAL THE BASE PLATE AND RETURN AIR DUCT CONNECTIONS MAY ALLOW CARBON MONOXIDE AND OTHER CONTAMINANTS TO BE DRAWN INTO THE CONDITIONED AIR SPACE AND DISTRIBUTED THROUGHOUT THE HEATED SPACE.

### WARNING

DO NOT OPERATE THE SYSTEM WITHOUT FILTERS. A PORTION OF THE DUST ENTRAINED IN THE AIR MAY TEMPORARILY LODGE IN THE AIR DUCT RUNS AND AT THE SUPPLY REGISTERS. ANY CIRCULATED DUST PARTICLES WILL BE HEATED AND CHARRED BY CONTACT WITH THE FURNACE HEAT EXCHANGER. THIS SOOTY RESIDUE WILL SOIL CEILINGS, WALLS, DRAPES, CARPETS AND OTHER HOUSEHOLD ARTICLES. SOOT DAMAGE MAY ALSO RESULT WITH, OR WITHOUT, FILTERS IN PLACE, WHEN CERTAIN TYPES OF CANDLES ARE BURNED, OR CANDLEWICKS ARE LEFT UNTRIMMED.

### WARNING

IN COMPLIANCE WITH RECOGNIZED CODES, IT IS RECOMMENDED THAT AN AUXILIARY DRAIN PAN BE INSTALLED UNDER THIS FURNACE AND ANY INSTALLED EVAPORATOR COIL THAT IS LOCATED IN ANY AREA OF A STRUCTURE WHERE DAMAGE TO THE BUILDING OR BUILDING CONTENTS MAY OCCUR AS A RESULT OF AN OVERFLOW OF THE A/C COIL DRAIN PAN.

# SAFETY INFORMATION

## **▲ WARNING**

BLOWER AND BURNERS MUST NEVER BE OPERATED WITHOUT THE BLOWER DOOR IN PLACE. THIS IS TO PREVENT DRAWING GAS FUMES (WHICH COULD CONTAIN HAZARDOUS CARBON MONOXIDE) INTO THE HOME THAT COULD RESULT IN PERSONAL INJURY OR DEATH.

## **▲ WARNING**

ALWAYS INSTALL THE FURNACE TO OPERATE WITHIN THE FURNACE'S INTENDED TEMPERATURE-RISE RANGE WITH A DUCT SYSTEM WHICH HAS AN EXTERNAL STATIC PRESSURE WITHIN THE ALLOWABLE RANGE, AS SPECIFIED IN THE DUCTING SECTION OF THESE INSTRUCTIONS. SEE ALSO FURNACE RATING PLATE.

THE FURNACE MAY BE USED FOR HEATING OF BUILDINGS OR STRUCTURES UNDER CONSTRUCTION.

INSTALLATION MUST COMPLY WITH ALL INSTALLATION INSTRUCTIONS INCLUDING:

- PROPER VENT INSTALLATION;
- FURNACE OPERATING UNDER THERMOSTAT CONTROL;
- RETURN AIR DUCT SEALED TO THE FURNACE;
- AIR FILTERS IN PLACE;
- SET FURNACE INPUT RATE AND TEMPERATURE RISE PER RATING PLATE MARKINGS;
- MEANS FOR PROVIDING OUTDOOR AIR REQUIRED FOR COMBUSTION;
- RETURN AIR TEMPERATURE MAINTAINED BETWEEN 55°F (13°C) AND 80°F (27°C); AND
- CLEAN FURNACE, DUCT WORK AND COMPONENTS UPON SUBSTANTIAL COMPLETION OF THE CONSTRUCTION PROCESS, AND VERIFY THAT THE FURNACE OPERATING CONDITIONS INCLUDING IGNITION, INPUT RATE, TEMPERATURE RISE AND VENTING, ACCORDING TO THE INSTRUCTIONS AND CODES.

## IMPORTANT INFORMATION ABOUT EFFICIENCY AND INDOOR AIR QUALITY

Central cooling and heating equipment is only as efficient as the duct system that carries the cooled or heated air. To maintain efficiency, comfort and good indoor air quality, it is important to have the proper balance between the air being supplied to each room and the air returning to the cooling and heating equipment.

Proper balance and sealing of the duct system improves the efficiency of the heating and air conditioning system and improves the indoor air quality of the home by reducing the amount of airborne pollutants that enter homes from spaces where the ductwork and / or equipment is located. The manufacturer and the U.S. Environmental Protection Agency's Energy Star Program recommend that central duct systems be checked by a qualified contractor for proper balance and sealing.

## **▲ WARNING**

DUCT LEAKS CAN CREATE AN UNBALANCED SYSTEM AND DRAW POLLUTANTS SUCH AS DIRT, DUST, FUMES AND ODORS INTO THE HOME CAUSING PROPERTY DAMAGE. FUMES AND ODORS FROM TOXIC, VOLATILE OR FLAMMABLE CHEMICALS, AS WELL AS AUTOMOBILE EXHAUST AND CARBON MONOXIDE (CO), CAN BE DRAWN INTO THE LIVING SPACE THROUGH LEAKING DUCTS AND UNBALANCED DUCT SYSTEMS CAUSING PERSONAL INJURY OR DEATH (SEE FIGURE 2).

- IF AIR-MOVING EQUIPMENT OR DUCTWORK IS LOCATED IN GARAGES OR OFF-GARAGE STORAGE AREAS - ALL JOINTS, SEAMS, AND OPENINGS IN THE EQUIPMENT AND DUCT MUST BE SEALED TO LIMIT THE MIGRATION OF TOXIC FUMES AND ODORS INCLUDING CARBON MONOXIDE FROM MIGRATING INTO THE LIVING SPACE.
- IF AIR-MOVING EQUIPMENT OR DUCTWORK IS LOCATED IN SPACES CONTAINING FUEL BURNING APPLIANCES SUCH AS WATER HEATERS OR BOILERS - ALL JOINTS, SEAMS, AND OPENINGS IN THE EQUIPMENT AND DUCT MUST ALSO BE SEALED TO PREVENT DEPRESSURIZATION OF THE SPACE AND POSSIBLE MIGRATION OF COMBUSTION BYPRODUCTS INCLUDING CARBON MONOXIDE INTO THE LIVING SPACE.

**FIGURE 2**  
MIGRATION OF DANGEROUS SUBSTANCES, FUMES, AND ODORS INTO LIVING SPACES

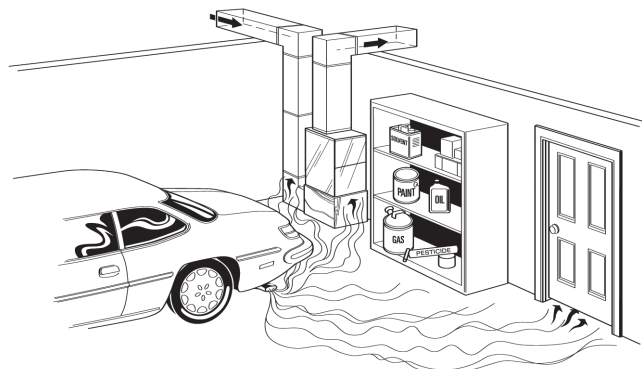

Adapted from *Residential Duct Diagnostics and Repair*, with permission of Air Conditioning Contractors of America (ACCA).

# LOCATION REQUIREMENTS

## GENERAL INFORMATION

### WARNING

WHEN THIS FURNACE IS INSTALLED IN A RESIDENTIAL GARAGE, IT MUST BE INSTALLED SO THE BURNERS AND IGNITION SOURCE ARE LOCATED NO LESS THAN 18 INCHES [450MM] ABOVE THE FLOOR. THIS IS TO PREVENT THE RISK OF IGNITING FLAMMABLE VAPORS WHICH MAY BE PRESENT IN A GARAGE. ALSO, THE FURNACE MUST BE LOCATED OR PROTECTED TO AVOID PHYSICAL DAMAGE BY VEHICLES. FAILURE TO FOLLOW THESE WARNINGS CAN CAUSE A FIRE OR EXPLOSION, RESULTING IN PROPERTY DAMAGE, PERSONAL INJURY OR DEATH.

1. **IMPORTANT:** If using a cooling evaporator coil with this furnace, be sure the air passes over the heat exchanger before passing over the cooling coil. The cooled air passing over the warm ambient air inside the heat exchanger tubes can cause condensation inside the tubes resulting in corrosion and eventual failure. An auxiliary drain pan should extend under any evaporator coil installed with the furnace.

If there are manual dampers, they must be equipped to prevent heating or cooling operation unless the damper is in the full heat or cool position.

2. **NOTE:** This furnace is shipped with heat exchanger support brackets installed under the back of the heat exchanger. These may be removed before installation, but it is not required.
3. **IMPORTANT:** *This furnace is not approved or recommended for installation on its back, with access doors facing upwards.*
4. This furnace is suitable for installation in buildings constructed on-site. This heating unit should be centralized with respect to the heat distribution system as much as practicable.
5. **NOTE:** These furnaces are approved for installation in attics, as well as alcoves, utility rooms, closets and crawlspaces.
6. **IMPORTANT:** *Support this unit when installed. For attic or crawl space installation, horizontal furnaces may be installed on combustible wood flooring or by using support brackets. See Figure 3.*
7. **IMPORTANT:** *If installing in a utility room, be sure the door is wide enough to:*
  - a. *allow the largest part of the furnace to pass; or*
  - b. *allow any other appliance (such as a water heater) to pass.*

### WARNING

THIS FURNACE IS NOT APPROVED OR RECOMMENDED FOR INSTALLATION ON ITS BACK, WITH ACCESS DOORS FACING UPWARDS.

## SITE SELECTION

1. Select a site in the building near the center of the proposed, or existing, duct system.
2. Give consideration to the vent system piping when selecting the furnace location. Be sure the venting system can get from the furnace to the termination with minimal length and elbows.
3. Locate the furnace near the existing gas piping. Or, if running a new gas line, locate the furnace to minimize the length and elbows in the gas piping.
4. Locate the furnace to maintain proper clearance to combustibles as shown in following Figure 4.

### WARNING

DO NOT LIFT THE UNIT BY THE HEAT EXCHANGER TUBES. DOING SO CAN DAMAGE THE HEAT EXCHANGER ASSEMBLY.

## CLEARANCE – ACCESSIBILITY

The design of forced air furnaces with input ratings as listed in the tables under Figure 4 are to combustible materials shown in inches.

See name/rating plate and clearance label for specific model number and clearance information.

Service clearance of at least 24 inches (30 cm) is recommended in front of all furnaces.

**NOTE:** Use recommended 24" (30 cm) clearance if accessibility clearances are greater than fire protection clearances.

**ACCESSIBILITY CLEARANCES, WHERE GREATER, MUST TAKE PRECEDENCE OVER FIRE PROTECTION CLEARANCES.**

# LOCATION REQUIREMENTS

## GENERAL INFORMATION (cont.)

### **▲ WARNING**

UPFLOW AND HORIZONTAL FURNACES ARE DESIGN-CERTIFIED FOR INSTALLATION ON COMBUSTIBLE FLOORS. NOTE, HOWEVER, THAT FURNACES MUST NOT BE INSTALLED DIRECTLY ON CARPETING, TILE OR OTHER COMBUSTIBLE MATERIAL OTHER THAN WOOD FLOORING. INSTALLATION ON A COMBUSTIBLE MATERIAL CAN RESULT IN FIRE, CAUSING PROPERTY DAMAGE, PERSONAL INJURY OR DEATH.

### **▲ WARNING**

COMBUSTIBLE MATERIAL MUST NOT BE PLACED ON OR AGAINST THE FURNACE JACKET. THE AREA AROUND THE FURNACE MUST BE KEPT CLEAR AND FREE OF ALL COMBUSTIBLE MATERIALS INCLUDING GASOLINE AND OTHER FLAMMABLE VAPORS AND LIQUIDS. PLACEMENT OF COMBUSTIBLE MATERIALS ON, AGAINST OR AROUND THE FURNACE JACKET CAN CAUSE AN EXPLOSION OR FIRE RESULTING IN PROPERTY DAMAGE, PERSONAL INJURY OR DEATH. THE HOMEOWNER SHOULD BE CAUTIONED THAT THE FURNACE AREA MUST NOT BE USED AS A BROOM CLOSET OR FOR ANY OTHER STORAGE PURPOSES.

FIGURE 3

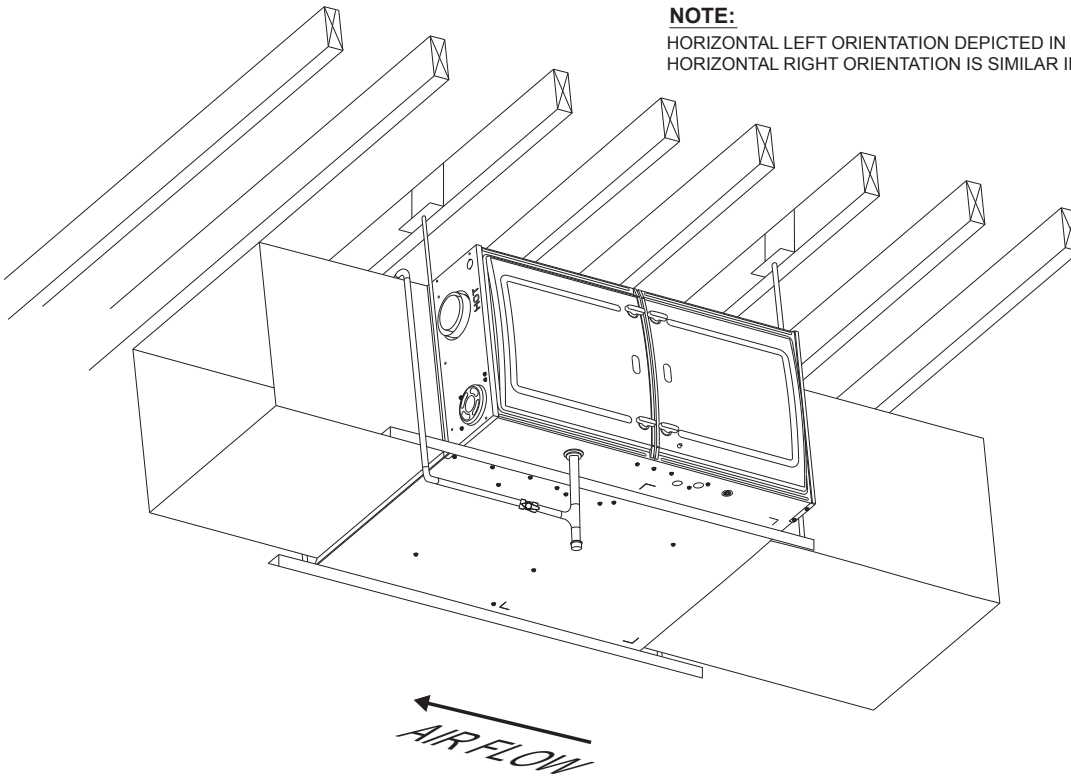

**NOTE:**

HORIZONTAL LEFT ORIENTATION DEPICTED IN ILLUSTRATION. HORIZONTAL RIGHT ORIENTATION IS SIMILAR IN INSTALLATION.

ST-A1220-03

**FIGURE 4**  
UPFLOW/HORIZONTAL DIMENSIONS

**CLEARANCE TO COMBUSTIBLE MATERIAL (INCHES)**  
**UPFLOW/HORIZONTAL MODELS**

Input	A	B	C	D	E	F	REDUCED CLEARANCE (IN.)			Ship. Wgts.	
							Left Side	Right Side	Top		Front
050	14	12 27/32	10 5/8	-	11 1/2	1 7/8	0	1	3	6 3/4	85 lbs.
070	17 1/2	16 11/32	12 3/8	-	15	2 1/2	0	3 3/4	3	6 3/4	105 lbs.
100	21	19 27/32	14 1/8	①	18 1/2	2 1/2	0	1	3	6 3/4	120 lbs.

- ① May require 4" to 5" adapter.
  - ② Type B1", Type BW1", Type L3".
  - ③ All connectors 6".
- \*\*See furnace spec. sheet for availability.

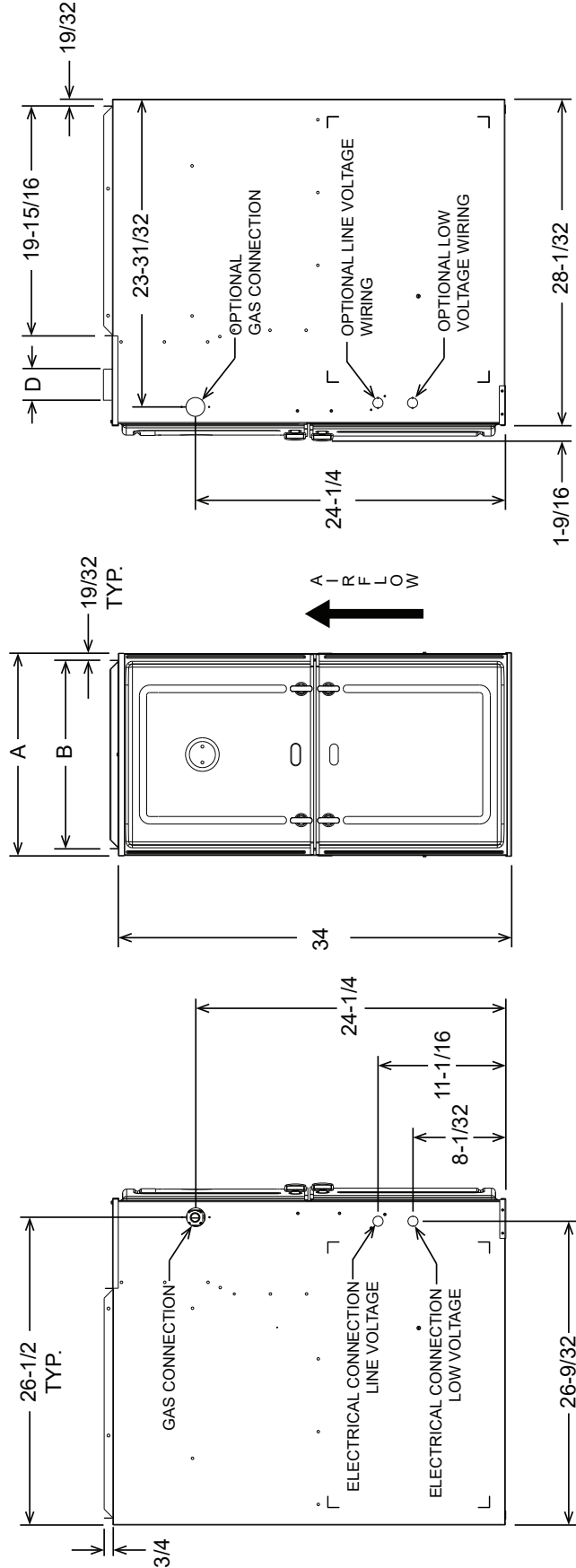
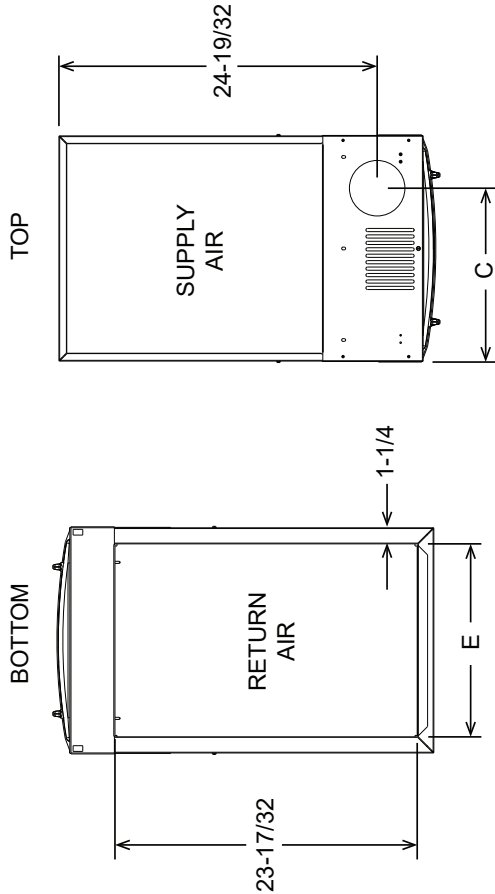

ST-A1252-28-01

RIGHT SIDE

FRONT

LEFT SIDE

Proper air flow is required for the correct operation of this furnace. Restricted air flow can cause erratic operation and can damage the heat exchanger. The duct system must carry the correct amount of air for heating and cooling if summer air conditioning is used.

## WARNING

**SOME HEATING AIRFLOW VALUES MAY BE HIGHER THAN THOSE REQUIRED FOR COOLING. BE SURE TO SIZE DUCT FOR THE MAXIMUM POSSIBLE AIRFLOW VALUE.**

**SIZE AIRFLOW DISTRIBUTION SYSTEM TO ACCEPTABLE INDUSTRY STANDARDS AND METHODS. TOTAL STATIC PRESSURE DROP OF THE AIR DISTRIBUTION SYSTEM SHOULD NOT EXCEED 1 INCH W.C. THIS WILL INCLUDE ANY AIR CONDITIONER COIL, AIR FILTRATION SYSTEM, ZONING SYSTEM, DUCTWORK, ETC. REFER TO ADDED EQUIPMENT TECHNICAL INFORMATION TO OBTAIN PRESSURE DROP INFORMATION WHEN EQUIPMENT IS OPERATING AT RECOMMENDED HEATING OR COOLING CFMS.**

**IMPORTANT:** When using outside air, design and adjust the system to maintain a return air temperature ABOVE 55° F during the heating season.

**NOTE:** Return air grilles and warm air registers must not be obstructed or closed.

## WARNING

**THE SOLID METAL BASE PLATE MUST BE INSTALLED IN THE FURNACE BOTTOM WHEN USING SIDE AIR RETURN. FAILURE TO INSTALL A BASE PLATE COULD CAUSE THE PRODUCTS OF COMBUSTION TO CIRCULATE INTO THE LIVING SPACE AND CREATE POTENTIALLY HAZARDOUS CONDITIONS, INCLUDING CARBON MONOXIDE POISONING OR DEATH. FOR BOTTOM RETURN, A SOLID METAL BASE PAN MUST NOT BE INSTALLED. SEE FIGURE 4.**

## UPFLOW INSTALLATIONS

1. Position the unit to minimize long runs of duct or runs of duct with many turns and elbows.
2. For side return: Cut an opening in the side. The opening should be cut the full width and height of the knockouts on the unit. See Figure 6.
3. If summer air conditioning is desired, position the indoor coil on the supply-air side of the unit. Ensure that no air can bypass the coil.
4. Connect the furnace to the supply air plenum. See Figure 6.
5. Connect the return air ducting to the return-air opening at the bottom and/or side of the unit. Make the connections air-tight to prevent the migration of toxic fumes and odors including carbon monoxide from migrating into the living space.
6. If a filter is installed near the furnace, be sure to have adequate space for installation and removal of the unit filter.
7. **NOTE:** Where the maximum airflow is 1800 CFM or more, **BOTH** sides or the bottom and one side must be used for the return air. Do not take return air from the back of the unit.

**NOTE:** DO NOT take return air from furnace rooms, garages or cold areas. Avoid return air from utility rooms, kitchens, laundry rooms and bathrooms.

## WARNING

**BLOWER AND BURNERS MUST NEVER BE OPERATED WITHOUT THE BLOWER DOOR IN PLACE. THIS IS TO PREVENT DRAWING GAS FUMES (WHICH COULD CONTAIN HAZARDOUS CARBON MONOXIDE) INTO THE HOME THAT COULD RESULT IN PERSONAL INJURY OR DEATH.**

# DUCTING

FIGURE 5

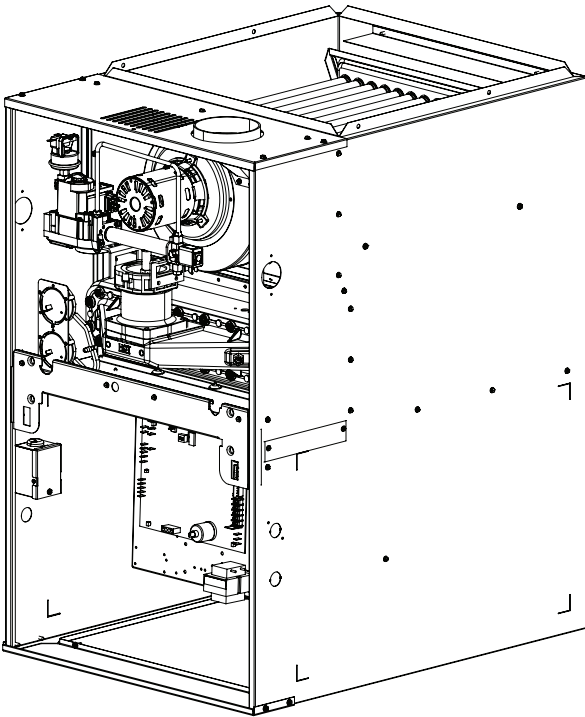

NOTE:  
SOLID BASE PLATE PROVIDED WITH (-)801T  
MODELS ONLY.

WHEN SOLID BASE PLATE IS USED, TAPE  
AROUND BOTTOM FLANGES OF CABINET  
BEFORE THE UNIT IS INSTALLED.

1. REMOVE 2 SCREWS, LIFT BASE UP, SLIDE FORWARD TO REMOVE.
2. INSTALLATION IS REVERSE OF REMOVAL.  
\*\*VERIFY REAR FLANGE IS SEALED PROPERLY AS SHOWN IN DETAIL

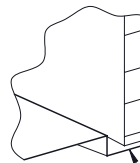

SOLID BASE FLANGE  
FITS UNDER  
CABINET BOTTOM

ST-A1252-03-01

FIGURE 6

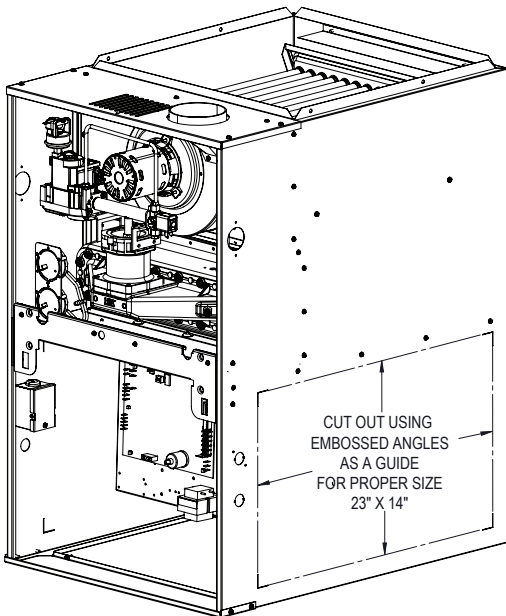

CUT OUT USING  
EMBOSSD ANGLES  
AS A GUIDE  
FOR PROPER SIZE  
23" X 14"

ST-A1252-04-01

FIGURE 7

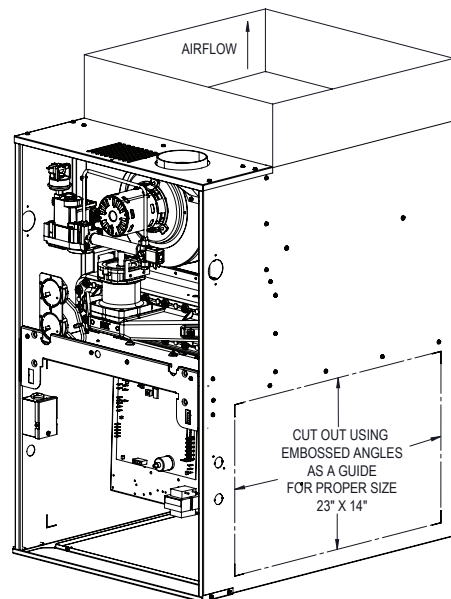

CUT OUT USING  
EMBOSSD ANGLES  
AS A GUIDE  
FOR PROPER SIZE  
23" X 14"

ST-A1252-05-01

## HORIZONTAL UNITS

1. Position the unit to minimize long runs of duct or runs of duct with many turns and elbows.
2. Unit can be mounted left or right side airflow configuration.
3. Position the unit on adequate supports or by using support brackets (see Figure 8) and connect supply plenum.
4. If summer air conditioning is desired, position the indoor coil on the supply air side of the unit. Insure that no air can bypass this coil.
5. Secure the four angle brackets to the return air opening. See Figure 9. Connect the return air ducting to the return air opening at the top of the unit. Make the connection air tight to prevent entraining combustion gases from an adjacent fuel-burning appliance.

**NOTE: Do not block furnace access with support rods. Maintain clearances recommended in Figure 8. Allow enough space for proper service maintenance or replacement of the heat exchanger and blower assembly.**

**FIGURE 8**  
HORIZONTAL FURNACE INSTALLED W/SUPPORT BRACKETS

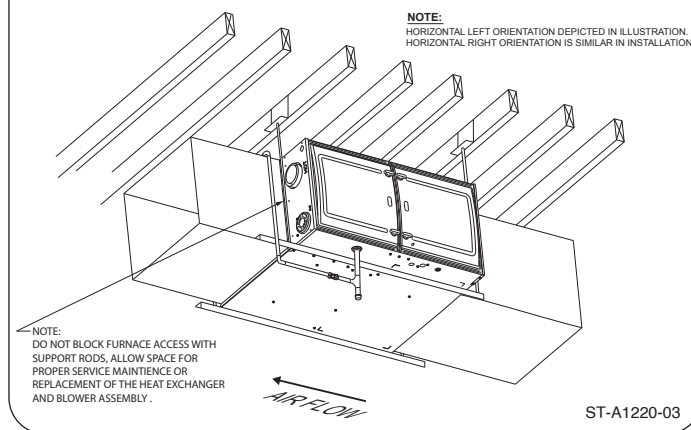

**FIGURE 9**  
HORIZONTAL RETURN AIR DUCT  
(LEFT-HAND AIRFLOW POSITION SHOWN)

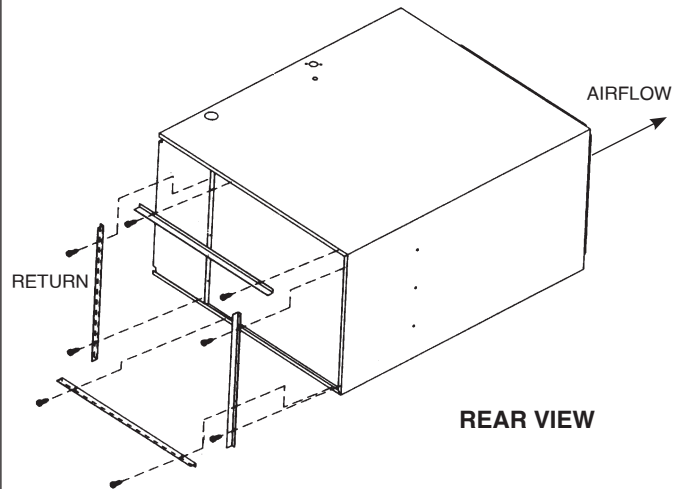

FOUR ANGLE BRACKETS, SHIPPED WITH 80% SINGLE STAGE CONSTANT TORQUE UNITS, CAN BE INSTALLED HORIZONTALLY. THESE BRACKETS MAY BE USED TO SECURE THE RETURN AIR DUCT TO A HORIZONTAL UNIT.

# COMBUSTION AND VENTILATION AIR

## COMBUSTION AIR REQUIREMENTS

**IMPORTANT:** *This is not a direct vent furnace. Review venting instructions before installing.*

### **WARNING**

**THIS FURNACE AND ANY OTHER FUEL-BURNING APPLIANCE MUST BE PROVIDED WITH ENOUGH FRESH AIR FOR PROPER COMBUSTION AND VENTILATION OF THE FLUE GASES. MOST HOMES WILL REQUIRE THAT OUTSIDE AIR BE SUPPLIED INTO THE FURNACE AREA. FAILURE TO DO SO CAN CAUSE DEATH FROM CARBON MONOXIDE POISONING.**

### **WARNING**

**ADEQUATE FACILITIES FOR PROVIDING AIR FOR COMBUSTION AND VENTILATION MUST BE PROVIDED IN ACCORDANCE WITH SECTION 5.3, AIR FOR COMBUSTION AND VENTILATION, OF THE NATIONAL FUEL GAS CODE, ANSI, Z223.1 LATEST EDITION OR APPLICABLE PROVISIONS FOR THE LOCAL BUILDING CODES, AND NOT OBSTRUCTED SO AS TO PREVENT THE FLOW OF AIR TO THE FURNACE.**

- IMPORTANT:** *Air for combustion and ventilation must not come from a corrosive atmosphere. Any failure due to corrosive elements in the atmosphere is excluded from warranty coverage.*
- Combustion air must be free of acid forming chemicals; such as sulphur, fluorine and chlorine. These elements are found in aerosol sprays, detergents, bleaches, cleaning solvents, air fresheners, paint and varnish removers, refrigerants and many other commercial and household products. Vapors from these products when burned in a gas flame form acid compounds. The acid compounds increase the dew point temperature of the flue products and are highly corrosive after they condense.
- The following types of installation may require **OUTDOOR AIR** for combustion, due to chemical exposures:
  - Commercial buildings
  - Buildings with indoor pools
  - Furnaces installed in laundry rooms
  - Furnaces in hobby or craft rooms
  - Furnaces installed near chemical storage areas.
- If combustion air is exposed to the following substances (but not limited to the following), it should not be used and the furnace may require outdoor air for combustion.
  - Permanent wave solutions
  - Chlorinated waxes and cleaners
  - Chlorine-based swimming pool chemicals
  - Water softening chemicals
  - De-icing salts or chemicals
  - Carbon tetrachloride

- Halogen type refrigerants
- Cleaning solvents (such as perchloroethylene)
- Printing inks, paint removers, varnishes, etc.
- Hydrochloric acid
- Cements and glues
- Antistatic fabric softeners for clothes dryers
- Masonry curing and acid washing materials

### **WARNING**

**ALL FURNACE INSTALLATIONS MUST COMPLY WITH THE NATIONAL FUEL GAS CODE AND LOCAL CODES TO PROVIDE ADEQUATE COMBUSTION AND VENTILATION AIR FOR THE FURNACE. FAILURE TO DO SO CAN CREATE HAZARDOUS CONDITIONS RESULTING IN PROPERTY DAMAGE, BODILY INJURY OR DEATH FROM SMOKE, FIRE OR CARBON MONOXIDE.**

Combustion air requirements are determined by whether the furnace is in an open (unconfined) area or in a confined space such as a closet or small room.

When the furnace is installed in the same space with other gas appliances, such as a water heater, be sure there is an adequate supply of combustion and ventilation air for the furnace and the other appliances. Do not delete or reduce the combustion air supply required by the other gas appliances in this space. See Z223.1, National Fuel Gas Code (NFPA 54). An unconfined space must have at least 50 cubic feet (volume) for each 1,000 BTUH of the total input of all appliances in the space. If the open space containing the appliances is in a building with tight construction (contemporary construction), outside air may still be required for the appliances to burn and vent properly. Outside air openings should be sized the same as for a confined space.

**IMPORTANT: ONLY THE CURRENT VENT INSTRUCTIONS APPLY.** All gas furnaces cannot be common-vented.

## OVER TEMPERATURE SAFETY SWITCHES

Furnaces are equipped with a safety switch on the combustion chamber to protect against over-temperature conditions caused by inadequate combustion air supply. The switches are located in the burner compartment. If a switch is tripped it must be manually reset after clearing the fault condition which caused it to open.

### **WARNING**

**DO NOT BYPASS, JUMPER, OR REMOVE ANY SAFETY SWITCH FROM THE FURNACE CONTROL CIRCUIT. IF A SAFETY SWITCH CAUSES THE FURNACE TO SHUT DOWN OR OPERATE INTERMITTENTLY, IT IS AN INDICATION OF A POTENTIAL SAFETY HAZARD THAT MUST BE ADDRESSED BY A QUALIFIED TECHNICIAN, SERVICE AGENCY OR THE GAS SUPPLIER. DO NOT RESET SAFETY CONTROLS WITHOUT CORRECTIVE ACTION AND/OR VERIFICATION OF PROPER SAFE OPERATION BY A QUALIFIED INSTALLER, SERVICE AGENCY OR THE GAS SUPPLIER.**

**REPLACE ANY SAFETY CONTROL COMPONENT WITH IDENTICAL OEM REPLACEMENT PARTS ONLY.**

# COMBUSTION AND VENTILATION AIR (cont.)

## COMBUSTION AIR REQUIREMENTS: CONFINED AND UNCONFINED SPACES

### WARNING

ALL FURNACE INSTALLATIONS MUST COMPLY WITH THE NATIONAL FUEL GAS CODE, NFPA 54 AND LOCAL CODES TO PROVIDE ADEQUATE COMBUSTION AND VENTILATION AIR FOR THE FURNACE. FAILURE TO DO SO CAN RESULT IN EXPLOSION, FIRE, PROPERTY DAMAGE, CARBON MONOXIDE POISONING, PERSONAL INJURY OR DEATH.

For improved indoor air quality, added safety and product performance we recommend direct vent type installations. If non-direct type vent system is used, the requirements for combustion air must be provided as identified in the National Fuel Gas Code.

Combustion air requirements are determined by whether the furnace is in an open (unconfined) area or in a confined space such as a closet or small room.

### WARNING

READ AND FOLLOW THE GENERAL VENTING REQUIREMENTS AND GUIDELINES OF THIS MANUAL FOR ADDITIONAL VENTING REQUIREMENTS PERTAINING TO ALL FURNACE INSTALLATIONS (INCLUDING DIRECT AND NON-DIRECT VENTING). FAILURE TO FOLLOW ALL INSTRUCTIONS IN THIS MANUAL CAN RESULT IN EQUIPMENT FAILURE, EQUIPMENT DAMAGE, PROPERTY DAMAGE, PERSONAL INJURY OR DEATH.

### FURNACE LOCATED IN AN UNCONFINED SPACE

#### USING INDOOR AIR FOR COMBUSTION:

An unconfined space must have at least 50 cubic feet for each 1,000 BTUH of total input for all appliances in the space. **Table 1** below specifies minimum space requirements and a few examples of the room sizes required for different inputs. The sizes are based on 8-foot ceilings.

If the open space containing the furnace is in a building with tight construction, outside air may still be required for the furnace to operate and vent properly. Outside air openings should be sized the same as for a confined space.

**TABLE 1: MINIMUM SPACE REQUIREMENTS FOR UNCONFINED SPACE, NON-DIRECT VENT.**

Input (BTUH)	Minimum Space (Cubic Ft)	Minimum Area with 8ft Ceilings (sq ft)	Typical Room Size w/8ft Ceilings (ft x ft)
50,000	2,500	313	16 × 20
70,000	3,500	438	22 × 20
98,000	4,900	613	31 × 20

### FURNACE LOCATED IN A CONFINED SPACE

A confined space is defined as any space for a given furnace input rating which is smaller than that which is specified in **Table 1** as minimum for an “unconfined” space. If the space is less than that specified in this table, the space is defined as “confined”.

If the space is small enough to be designated as “confined”, it must have openings into the space which are located in accordance with the requirements set forth in the following subsections A and B. Size connected to the heated area or to the outside, and by the input of **ALL** appliances in the space.

If the confined space is within a building with tight construction, combustion air must be taken from outdoors or from an area freely communicating with the outdoors.

#### A. USING INDOOR AIR FOR COMBUSTION:

**IMPORTANT:** Air should not be taken from a heated space with a fireplace, exhaust fan or other device that may produce negative pressure.

If combustion air is taken from the heated area, the openings must each have at least 100 square inches of free area. Each opening must have at least one square inch of free area for each 1,000 BTUH of total input in the space. **Table 2** shows some typical examples of openings required for combustion air openings required for a confined space.

**TABLE 2: MINIMUM FREE AREA OPENING REQUIRED FOR A FURNACE LOCATED IN A CONFINED SPACE USING INDOOR AIR FOR COMBUSTION.**

Input (BTUH)	Free Area for Each Opening (sq inches)
50,000	100
70,000	100
98,000	100

#### B. USING OUTDOOR AIR FOR COMBUSTION:

**IMPORTANT:** Do not take air from an attic space that is equipped with power ventilation.

The confined space must communicate with the outdoors in accordance with Methods 1 or 2 below. The minimum dimension of air openings shall not be less than 3 inches. Where ducts are used, they shall be of the same cross-sectional area as the free area of the openings to which they connect.

##### METHOD 1:

Two permanent openings, one located within 12 inches of the top and one located within 12 inches of the bottom of the enclosure, shall be provided. The openings shall communicate directly, or by ducts, with the outdoors or spaces (crawl or attic) that freely communicate with the outdoors.

# COMBUSTION AND VENTILATION AIR (cont.)

## COMBUSTION AIR REQUIREMENTS: CONFINED AND UNCONFINED SPACES

**TABLE 3: MINIMUM FREE AREA REQUIRED FOR EACH OPENING (WHEN TWO OPENINGS ARE USED) WITH A FURNACE:**

1. LOCATED IN A CONFINED SPACE
2. USING OUTDOOR AIR FOR COMBUSTION
3. COMMUNICATING DIRECTLY TO THE OUTSIDE THROUGH AN OPENING OR THROUGH A VERTICAL DUCT.

Total Input for ALL Gas Appliances (BTUH)	Free Area for Each Opening when 2 Separate Openings are used (sq inches)	Round Pipe Duct Diameter (Vertical Duct Only) (inches)
50,000	13	5
70,000	18	5
98,000	25	6

- A. Where directly communicating with the outdoors through an opening or where communicating to the outdoors through vertical ducts as shown in **Figure 11**, each opening shall have a minimum free area of 1 square inch for each 4,000 BTUH of total appliance input rating of all equipment in the enclosure. **Table 3** specifies the minimum area for each of the 2 combustion air openings and minimum round duct diameter for direct openings and vertical ducting only.
- B. Where communicating with the outdoors through horizontal ducts, each opening shall have a minimum free area of 1 square inch for each 2,000 BTUH of total appliance input

**TABLE 4: MINIMUM FREE AREA REQUIRED FOR EACH OPENING (WHEN TWO OPENINGS ARE USED) WITH A FURNACE:**

1. LOCATED IN A CONFINED SPACE
2. USING OUTDOOR AIR FOR COMBUSTION
3. COMMUNICATING DIRECTLY TO THE OUTSIDE THROUGH A HORIZONTAL DUCT.

Total Input for ALL Gas Appliances (BTUH)	Free Area for Each Opening when 2 Separate Openings are used (sq inches)	Round Pipe Duct Diameter (Horizontal Duct Only) (inches)
50,000	25	6
70,000	35	8
98,000	49	8

**TABLE 5: MINIMUM FREE AREA REQUIRED FOR EACH OPENING (WHEN TWO OPENINGS ARE USED) WITH A FURNACE:**

1. LOCATED IN A CONFINED SPACE
2. USING OUTDOOR AIR FOR COMBUSTION
3. COMMUNICATING DIRECTLY TO THE OUTSIDE THROUGH A HORIZONTAL DUCT.

Total Input for ALL Gas Appliances (BTUH)	Free Area for an Opening when 1 Opening is used (sq inches)	Round Pipe Duct Diameter (inches)
50,000	25	6
70,000	35	8
98,000	49	8

rating of all equipment in the enclosure (see **Figure 12**). **Table 4** specifies the minimum area for each of the 2 combustion air openings and minimum round duct diameter for horizontal ducting only.

**METHOD 2:**

One permanent opening located within 12 inches of the top of the enclosure, shall be permitted where the equipment has clearances of at least 1 inch from the sides and back and 6 inches from the front of the appliance. The opening shall directly communicate with the outdoors or communicate through a vertical or horizontal duct to the outdoors or spaces (crawl or attic) that freely communicate with the outdoors, and shall have a minimum of:

**FIGURE 10**  
NON-DIRECT VENT  
AIR FROM  
HEATED  
SPACE

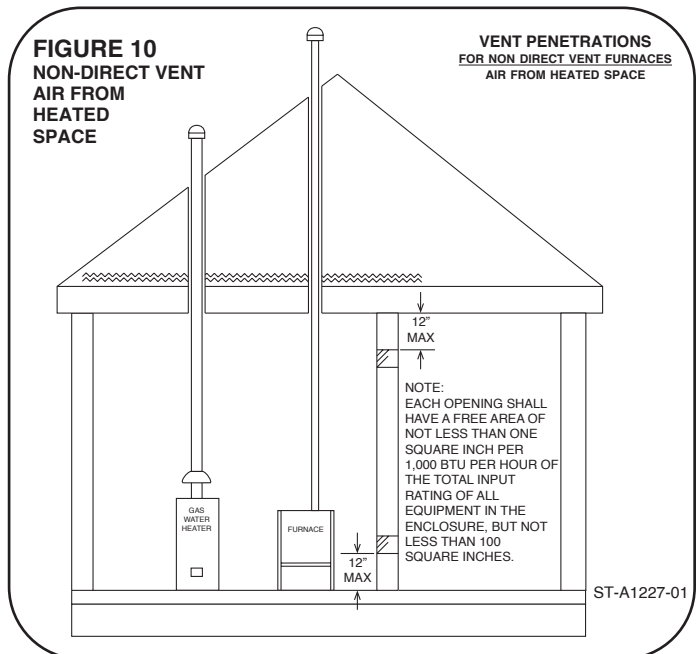

# COMBUSTION AND VENTILATION AIR (cont.)

## COMBUSTION AIR REQUIREMENTS: CONFINED AND UNCONFINED SPACES

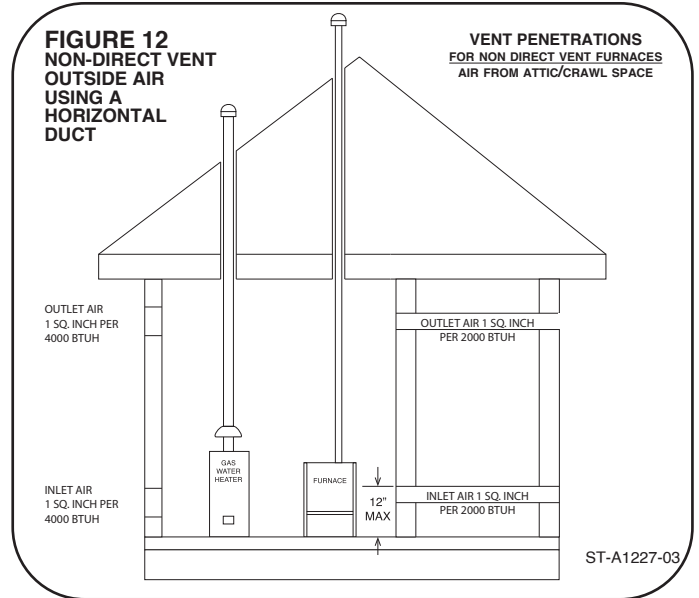
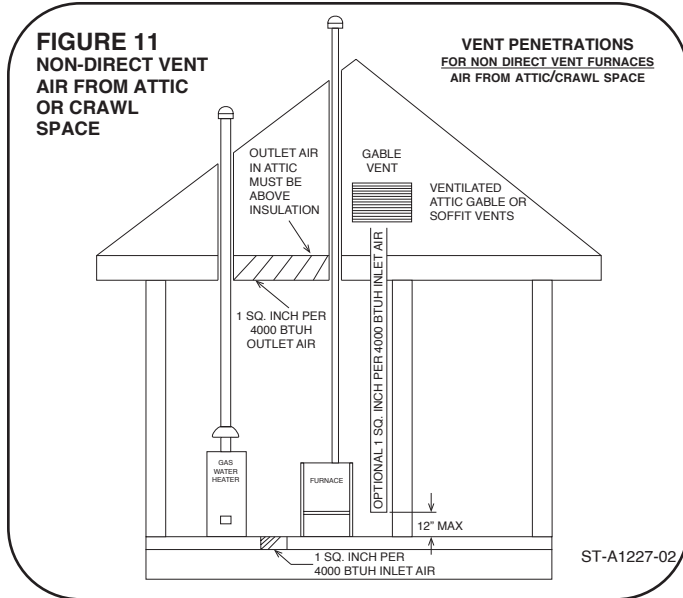

- A. 1 square inch for each 3,000 BTUH of the total input rating of all equipment located in the enclosure
- B. Not less than the sum of the areas of all vent connectors in the confined space.

If the unit is installed where there is an exhaust fan, sufficient ventilation must be provided to prevent the exhaust fan from creating negative pressure.

Combustion air openings must not be restricted in any manner.

**IMPORTANT:** When indoor combustion air is used, the inlet air openings at the furnace must be protected from accidental blockage.

**IMPORTANT:** *If the furnace is in a location with an exhaust fan, there must be sufficient ventilation to prevent the exhaust fan from creating a negative pressure in the room.*

Combustion air openings must **NOT BE RESTRICTED** in any manner.

CONSULT LOCAL CODES FOR SPECIAL REQUIREMENTS.

### METHOD 3:

For the optimum in quiet operation, attic air may be brought directly to the furnace.

**IMPORTANT:** In applications using Method 3 for combustion air, the attic must be ventilated by gable or soffit vents.

### **CAUTION**

**COMBUSTION AIR INTAKES CANNOT BE TERMINATED OUTSIDE. DOING SO CAN CAUSE IMPROPER OPERATION OF THE FURNACE.**

## COMBUSTION AIR FROM ATTIC

If attic combustion air is used, the inlet air openings at the furnace must be protected from accidental blockage.

# COMBUSTION AND VENTILATION AIR (cont.)

## VENTING

### GENERAL INFORMATION

The furnace must be vented in accordance with these instructions, National Fuel Gas Code, ANSI Z223.1 and requirements or codes of the local utility or other authority having jurisdiction.

#### **▲ WARNING**

**DEVICES ATTACHED TO THE FLUE OR VENT FOR THE PURPOSE OF REDUCING HEAT LOSS UP THE CHIMNEY HAVE NOT BEEN TESTED AND HAVE NOT BEEN INCLUDED IN THE DESIGN CERTIFICATION OF THIS FURNACE. WE, THE MANUFACTURER, CANNOT AND WILL NOT BE RESPONSIBLE FOR INJURY OR DAMAGE CAUSED BY THE USE OF SUCH UNTESTED AND/OR UNCERTIFIED DEVICES, ACCESSORIES OR COMPONENTS.**

### DRAFT INDUCER

#### **▲ WARNING**

**VENT PIPE ATTACHING HOLES MUST BE PREDRILLED IN THE DRAFT INDUCER COLLAR TO PREVENT DAMAGING THE INDUCER. DRILL 1/8" DIAMETER HOLES THROUGH THE VENT PIPE AND COLLAR AND USE #8 SCREWS TO ATTACH. SEE FIGURE 14. FAILURE TO FOLLOW THIS WARNING CAN CAUSE RECIRCULATION OF FLUE PRODUCTS CAUSING CARBON MONOXIDE POISONING RESULTING IN PERSONAL INJURY OR DEATH.**

### FURNACE CATEGORY INFORMATION

This furnace is shipped as a Category I type induced draft furnace. A Category I furnace operates with a nonpositive vent pressure and has a vent gas temperature at least 140°F above the dew point of the vent gases. A Category I type may be a draft hood equipped furnace or have a fan assisted combustion system (induced draft). The inducer is used to pull flue products through the combustion chamber and as they leave the furnace, most of the energy has been dissipated. The buoyant effect of the flue gases provides venting to the outdoors.

During the off cycle, the inducer is off and there is very little flow through the vent, cooling the vent. During the on cycle there is no dilution airflow, as with a draft hood type furnace. Although the vent heats up rapidly without dilution air, the flue products contain more water vapor, which results in a higher dew point temperature. It is most **important** that you follow the guidelines in these instructions to prevent the possible formation of condensation in the venting system.

As a Category I furnace it may be vented vertically with type B-1 vent pipe and also may be common vented, as described in these instructions.

### IMPORTANT APPLICATION NOTES

When the furnace is used as a replacement, the existing vent system should be inspected to assure that there are no obstructions, blockage, or any signs of corrosion and is properly sized for use with this furnace.

**NOTE:** When the vent table permits more than one diameter of pipe for a connector or vent, the smallest permitted diameter must be used.

Vent pipe may be type "B-1," either rigid or suitable flexible construction that carries a U.L. listing.

Common venting is allowed with vertical B-1 vent systems, and lined masonry chimneys. Follow the National Fuel Gas Code ANSI Z223.1 or proper installation practices.

**NOTE:** Follow combustion air instructions as outlined in this manual.

Single wall vent connectors to "B-1 vent or masonry chimneys" may be used under the guidelines of the National Fuel Gas Code ANSI Z223.1.

**The entire length of the vent connector shall be readily accessible for inspection, cleaning and replacement.**

### "B-1" VERTICAL VENTING

**NOTE:** Refer to the National Fuel Gas Code, ANSI Z223.1.

Type "B-1" vents must be installed in accordance with the terms of their listings and the vent manufacturer's instructions.

"B-1" vents must be supported and spaced in accordance with their listings and the manufacturer's instructions. All vents must be supported to maintain their minimum clearances from combustible material.

VERTICAL VENTING	
Input	Categorized Furnace Vent Size Recommended (See NFGC)
50K	*4"
70K	*4"
98K	*5"

\*NOTE: All furnaces have a 4" vent connection as shipped from the factory. A 4" to 5" vent transition may be required. **THE VENT TRANSITION CONNECTION MUST BE MADE AT THE FURNACE VENT EXIT.** It must originate with an adapter if required, at the furnace flue collar and terminate either in a listed cap or roof assembly. When common venting, the vent connector size may differ from the above diameters depending on application. See National Fuel Gas Code ANSI Z223.1 or latest edition tables.

# COMBUSTION AND VENTILATION AIR (cont.)

## VERTICAL VENT SYSTEMS:

1. A gas vent shall terminate above the roof surface with a listed cap or listed roof assembly. Gas vents 12 inches in size or smaller with listed caps shall be permitted to be terminated in accordance with Figure 13, provided they are at least 8 feet from a vertical wall or similar obstruction. All other gas vents shall terminate not less than 2 feet above the highest point where they pass through the roof and at least 2 feet higher than any portion of a building within 10 feet.
2. A type B-1 gas vent shall terminate at least 5 feet in vertical height above the highest connected equipment draft hood or flue collar.
3. Must rise  $\frac{1}{8}$ " per foot away from the furnace on horizontal runs and be supported with straps or hangers so it has no sags or dips. Supports at 4 foot intervals and at all elbows are recommended.
4. The vent connector must be mechanically fastened to the outlet collar of the furnace with at least (2) sheet metal screws except vent connectors that are B-1 material. These shall be assembled in accordance with the manufacturer's instructions. See Figure 14.
5. Any angle greater than 45 degrees from the vertical is considered horizontal. The total horizontal distance of a vent plus the horizontal vent connector serving draft-hood equipped appliances shall not be greater than 75 percent of the vertical height of the vent.

Single appliance venting of a fan assisted furnace into a tile-lined masonry chimney is prohibited. The chimney must be lined with either Type B vent or with a listed, single wall, metal lining system. Reference National Fuel Gas Code, ANSI Z223.1. See Figure 15 for typical B-1 vent chase.

**NOTE:** A chimney adapter is available as an accessory (see accessory section of this manual). Follow manufacturer's instructions.

### WARNING

**DO NOT CONNECT THIS FURNACE TO A CHIMNEY USED TO VENT A SOLID FUEL APPLIANCE (WOOD OR COAL). VENTING WITH A SOLID FUEL APPLIANCE CAN LEAD TO IMPROPER FUNCTIONING OF THE UNIT, AND DUE TO SOOTING, THE POSSIBILITY OF FIRE RESULTING IN PROPERTY DAMAGE, PERSONAL INJURY OR DEATH.**

## SPECIAL VENT SYSTEMS (SVS)

**IMPORTANT:** It is *THE FURNACE MANUFACTURER's* position now that new installations of any HTPV pipe used in a category III vent application, including Selkirk's Selvent™ II HTPV product, should *cease immediately*.

**FIGURE 13**  
TYPICAL VENTING WITH "B-1" VENT

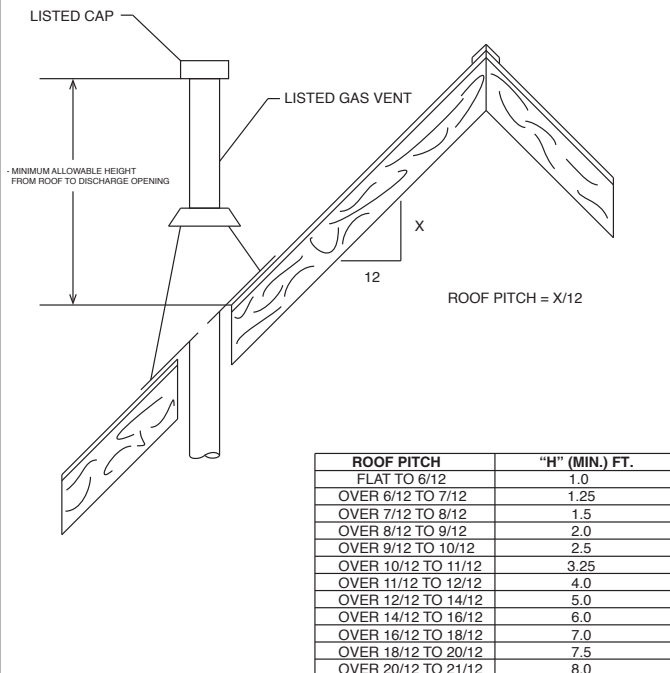

ST-A1220-24

**FIGURE 14**  
ATTACHING TO DRAFT INDUCER COLLAR

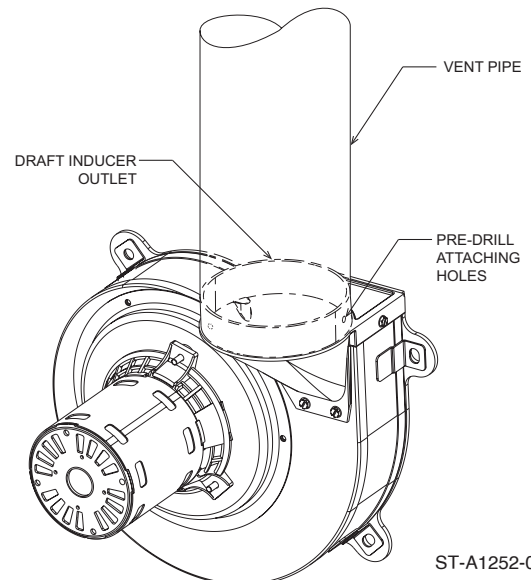

ST-A1252-06-00

# COMBUSTION AND VENTILATION AIR (cont.)

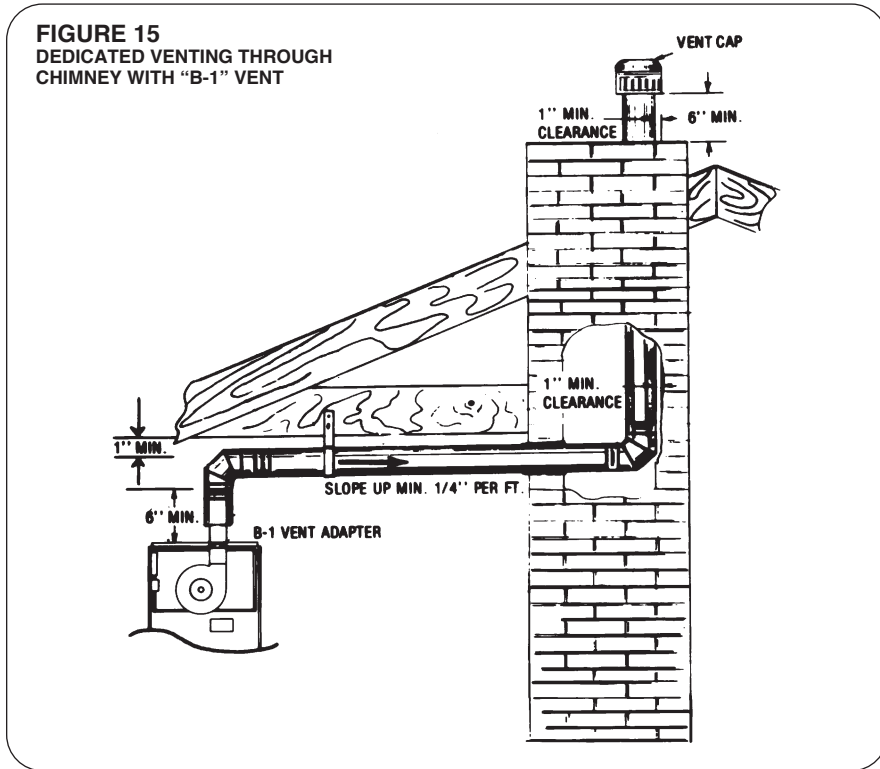

## EXISTING VENT SYSTEMS IMPORTANT RETROFIT VENTING INSTRUCTIONS

If this furnace is a replacement installation, **ALWAYS INSPECT** the existing vent system to be sure there are no obstructions, blockages, or signs of corrosion.

When the existing furnace is removed from a venting system serving other appliances, the venting is likely to be too large to properly vent the remaining attached appliances.

The following steps shall be followed with each appliance that remains connected to the common venting system, while the other appliances that remain connected to the common venting systems are not in operation.

**NOTE: When the vent table permits more than one diameter of pipe for a connector or vent, the smallest permitted diameter must be used. Seal any unused openings in the common venting system.**

**NOTE:** Ensure existing venting system complies with latest addition of National Fuel Gas Code ANSI Z223.1 and all local codes/regulations.

1. Visually inspect the venting system for proper size and horizontal pitch and determine that there is no blockage, restriction, leakage, corrosion or other deficiencies which could cause an unsafe condition.

2. Insofar as is practical, close all building doors, windows and all doors between the space where the appliances remaining connected to the common venting system are located. Turn on clothes dryers and any appliance not connected to the common venting system. Turn on any exhaust fans, such as range hoods and bathroom exhausts, so they will operate at maximum speed. Do not operate a summer exhaust fan. Close fireplace dampers.
3. Follow the lighting instructions. Place the appliance being inspected into operation. Adjust the thermostat so the appliance will operate continuously.
4. Test for spillage at the draft hood relief opening after 5 minutes of main burner operation. Use the flame of a match or candle, or smoke from a cigarette, cigar, or pipe.
5. After it has been determined that each appliance that remains connected to the common venting system properly vents (when tested as outlined above) return doors, windows, exhaust fans, fireplace dampers and any other gas-burning appliance to their previous conditions of use.
6. If improper venting is observed during any of the above tests, the common venting system must be resized. Refer to National Fuel Gas Code, ANSI Z223.1.

## GAS SUPPLY AND PIPING

### IMPORTANT SAFETY INFORMATION

#### NATURAL GAS SAFETY

#### GAS SUPPLY

##### WARNING

- THIS FURNACE IS NOT CERTIFIED FOR USE WITH LP GAS. DO NOT ATTEMPT TO CONVERT OR OPERATE WITH LP GAS. A NATURAL GAS HEATER WILL NOT FUNCTION SAFELY ON PROPANE AND VICE VERSA. THE FURNACE SHOULD ONLY USE THE FUEL TYPE IN ACCORDANCE WITH LISTING ON RATING PLATE. ANY OTHER FUEL USAGE WILL RESULT IN DEATH OR SERIOUS PERSONAL INJURY FROM FIRE AND/OR EXPLOSION.
- NATURAL GAS HAS AN ODORANT ADDED TO AID IN DETECTING A GAS LEAK. SOME PEOPLE MAY NOT PHYSICALLY BE ABLE TO SMELL OR RECOGNIZE THIS ODORANT. IF YOU ARE UNSURE OR UNFAMILIAR WITH THE SMELL OF NATURAL GAS, ASK YOUR LOCAL GAS SUPPLIER. OTHER CONDITIONS, SUCH AS "ODORANT FADE," WHICH CAUSES THE ODORANT TO DIMINISH IN INTENSITY, CAN ALSO HIDE, CAMOUFLAGE, OR OTHERWISE MAKE DETECTING A GAS LEAK BY SMELL MORE DIFFICULT.
- UL OR CSA RECOGNIZED FUEL GAS DETECTORS ARE RECOMMENDED IN ALL ENCLOSED NATURAL GAS APPLICATIONS WHEREIN THERE IS A POTENTIAL FOR AN EXPLOSIVE MIXTURE OF FUEL GAS TO ACCUMULATE. FUEL DETECTOR INSTALLATION SHOULD BE IN ACCORDANCE WITH THE DETECTOR MANUFACTURER'S RECOMMENDATIONS AND/OR LOCAL LAWS, RULES, REGULATIONS, OR CUSTOMS.
- BEFORE ATTEMPTING TO LIGHT THE FURNACE, MAKE SURE TO LOOK AND SMELL FOR GAS LEAKS. USE A SOAPY SOLUTION TO CHECK ALL GAS FITTINGS AND CONNECTIONS.

BUBBLING AT A CONNECTION INDICATES A LEAK THAT MUST BE CORRECTED. WHEN SMELLING TO DETECT A GAS LEAK, BE SURE TO ALSO SNIFF NEAR THE FLOOR. PROPANE GAS IS HEAVIER THAN AIR AND TENDS TO COLLECT AT LOWER LEVELS MAKING IT MORE DIFFICULT TO SMELL AT NOSE LEVEL. NATURAL GAS IS LIGHTER THAN AIR AND WILL RISE, POSSIBLY ACCUMULATING IN HIGHER PORTIONS OF THE STRUCTURE.

*(Continued on next column)*

- IF A GAS LEAK IS PRESENT OR SUSPECTED:
  - DO NOT ATTEMPT TO FIND THE CAUSE YOURSELF.
  - NEVER USE AN OPEN FLAME TO TEST FOR GAS LEAKS. THE GAS CAN IGNITE RESULTING IN DEATH, PERSONAL INJURY, OR PROPERTY DAMAGE.
  - DO NOT TRY TO LIGHT ANY APPLIANCE.
  - DO NOT TOUCH AND ELECTRICAL SWITCH.
  - DO NOT USE ANY PHONE IN YOUR BUILDING.
  - LEAVE THE BUILDING IMMEDIATELY AND CALL THE GAS SUPPLIER FROM A NEIGHBOR'S PHONE. FOLLOW THE GAS SUPPLIER'S INSTRUCTIONS.
  - IF YOU CANNOT REACH YOUR GAS SUPPLIER, CALL THE FIRE DEPARTMENT.
  - DO NOT RETURN TO THE BUILDING UNTIL AUTHORIZED BY THE GAS SUPPLIER OR FIRE DEPARTMENT.
- SHOULD OVERHEATING OCCUR OR THE GAS SUPPLY FAIL TO SHUT OFF, TURN OFF THE MANUAL GAS CONTROL VALVE TO THE FURNACE.
- CONSULT WITH THE LOCAL BUILDING DEPARTMENT AND FUEL GAS SUPPLIER BEFORE INSTALLING THE HEATER:
  - THE INSTALLATION AND PURGING OF GAS PIPING MUST CONFORM TO LOCAL CODES, UTILITY COMPANY REQUIREMENTS, AND THE LATEST EDITION OF NATIONAL FUEL GAS CODE (NFGC) - ANSI Z223.1/NFPA 54.
  - INSTALLATION OF A GAS PRESSURE REGULATOR MAY BE REQUIRED IN THE GAS SUPPLY LINE. THE REGULATOR SHOULD NOT EXCEED THE MAXIMUM SUPPLY PRESSURE LISTED ON THE FURNACE RATING PLATE. DO NOT USE AN INDUSTRIAL-TYPE GAS REGULATOR.
  - FOLLOW ALL LOCAL CODES AND SECTION 8.3 OF NFGC WITH REGARD TO PURGING OF GAS PIPING TO ENSURE THAT THE AIR AND/OR FUEL GAS IN THE GAS PIPING IS PROPERLY VENTED TO A LOCATION WHERE AN EXPLOSIVE MIXTURE CANNOT ACCUMULATE.

# GAS SUPPLY

## GAS PIPING

### ▲ WARNING

**THIS FURNACE IS EQUIPPED AT THE FACTORY FOR USE ON NATURAL GAS ONLY. THIS FURNACE IS NOT CERTIFIED FOR USE WITH LP GAS. DO NOT ATTEMPT TO CONVERT OR OPERATE WITH LP GAS.**

**IMPORTANT:** Any additions or changes required for the furnace to satisfactorily meet the application should be made by a qualified installer, service agency or the gas supplier, using factory-specified or approved parts.

**IMPORTANT:** Connect this furnace only to gas supplied by a commercial utility or commercial fuel provider.

**IMPORTANT:** A U.L. or CSA recognized fuel gas and CO detector(s) are recommended in all applications, and their installation should be in accordance with the detector manufacturer's recommendations and/or local laws, rules, regulations or customs.

Install the gas piping according to all local codes, state codes and regulations of the utility company, whichever holds jurisdiction.

If possible, run a separate gas supply line directly from the meter to the furnace. Consult the local gas company for the location of the manual main shut-off valve. **The gas line and manual gas valve must be adequate in size to prevent undue pressure drop and never smaller than the pipe size to the combination gas valve on the furnace.** Refer to Table 6 for the recommended pipe size for natural gas.

**IMPORTANT:** It is permissible to run flexible gas connector inside the unit to a piece of black pipe. If local codes allow the use of a flexible gas appliance connector, always use a new listed connector. Do not use a connector which has previously serviced another gas appliance. Massachusetts law limits flexible gas connectors to a maximum of 36".

Install a ground joint union outside the cabinet and within 3 feet to easily remove the control valve assembly. Install a manual shut-off valve in the gas line outside the furnace casing. The valve should be readily accessible to turn the gas supply on or off. Install a drip leg in the gas supply line as close to the furnace as possible. Always use a pipe compound resistant to the action of liquefied petroleum gases on all threaded connections.

**IMPORTANT:** When making gas pipe connections, use a back-up wrench to prevent any twisting of the control assembly and gas valve. Do not overtighten the connection.

**IMPORTANT:** ENSURE that the furnace gas control valve not be subjected to high gas line supply pressures.

DISCONNECT the furnace and its individual shut-off valve from the gas supply piping during any pressure testing that exceeds ½ PSIG (3.48 kPa).

**FIGURE 16A**  
GAS PIPING INSTALLATION

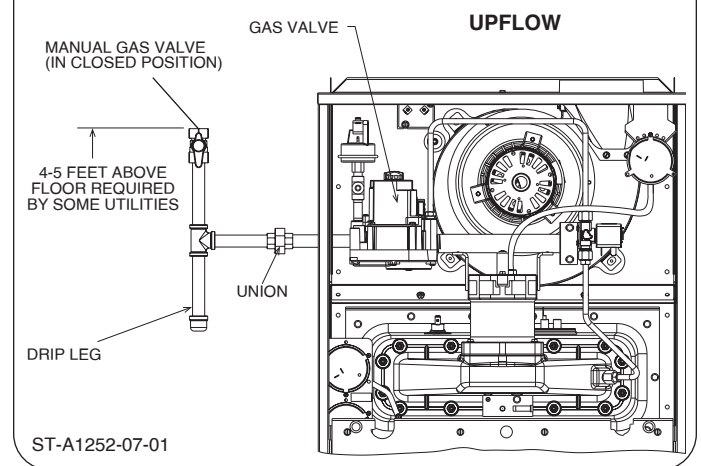

## ALTERNATE GAS LOCATION INSTRUCTIONS

The gas supply piping can be routed to the opposite side of the furnace by reversing the manifold on the venturi housing and changing the aluminum tubing to the pilot. This procedure is detailed in the steps below. When the conversion is complete test for leaks at the compression fitting joints when the tubing is active (during an ignition cycle only).

1. Remove the inlet pressure switch by removing the (2) screws in the top plate.
2. Remove the lower aluminum tubing from the pilot to the pilot solenoid by loosening (2) compression fittings with 3/8" wrench. It will be necessary to use a backup wrench on the mating adapter so that you loosen only the compression fitting. It is not necessary to remove the aluminum tube from the main gas valve to the pilot solenoid.
3. Remove (4) 8-32 machine screws from the venturi housing, reverse the manifold assembly, and reinstall the screws.
4. From the parts bag get the designated tube for your installation and (2) compression fittings. Slide the fittings over the end of the tube and insert the tube making sure the tube bottoms out in the mating fitting. Tighten the compression fitting until the feral breaks off and tighten to approximately 60 in-lbs. Repeat this process for opposite end of the tube.
5. Install pressure switch, check for leaks in the pilot tubing, and ensure there are no kinks in the tube.

**FIGURE 16B**  
ALTERNATE GAS PIPING INSTALLATION

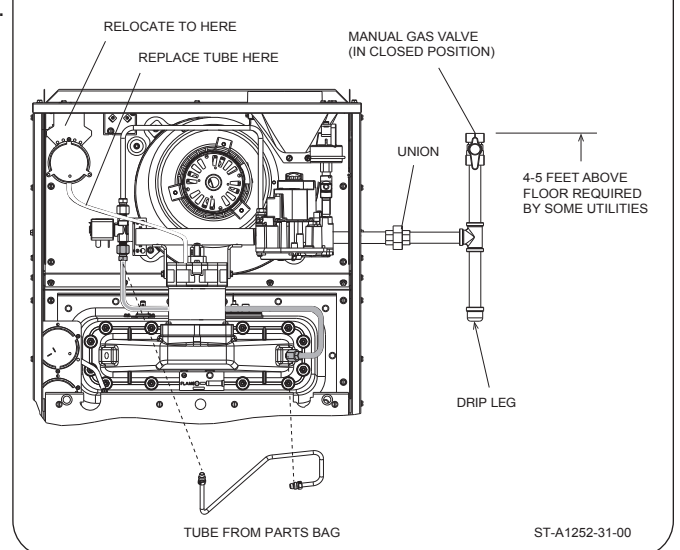

# GAS SUPPLY (cont.)

## GAS PRESSURE

**IMPORTANT:** ENSURE that the furnace gas valve is not to be subjected to high gas line supply pressures.

DISCONNECT the furnace and its individual manual gas stop from the gas supply piping during **any pressure testing that exceeds ½ PSIG. (3.48 kPa).**

**Natural gas supply pressure must be 6" to 10.5" w.c.** This pressure must be maintained with all other gas-fired appliances in operation.

The minimum gas supply pressure to the gas valve for proper furnace input adjustments is 6" w.c. for natural gas, however 7" is recommended. This furnace is equipped with a gas pressure switch that will not allow operation below 5" w.c. of inlet gas pressure.

### WARNING

**NEVER PURGE A GAS LINE INTO THE COMBUSTION CHAMBER. NEVER USE MATCHES, FLAME OR ANY IGNITION SOURCE FOR CHECKING LEAKAGE. FAILURE TO ADHERE TO THIS WARNING CAN CAUSE A FIRE OR EXPLOSION RESULTING IN PROPERTY DAMAGE, PERSONAL INJURY OR DEATH.**

**TO CHECK FOR GAS LEAKAGE, USE AN APPROVED CHLORIDE-FREE SOAP AND WATER SOLUTION, OR OTHER APPROVED METHOD.**

**FIGURE 17A**  
TYPICAL GAS VALVE (HONEYWELL)

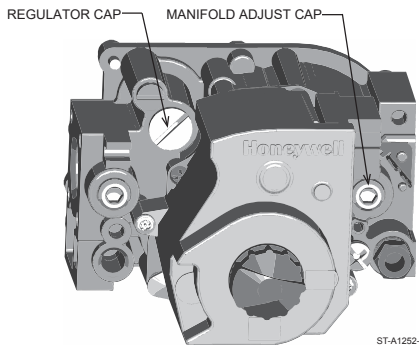

ST-A1252-29-00

**TABLE 6**  
NATURAL GAS PIPE CAPACITY TABLE (CU. FT./HR.)

Capacity of gas pipe of different diameters and lengths in cu. ft. per hr. with pressure drop of 0.3 in. and specific gravity of 0.60 (natural gas).

Nominal Iron Pipe Size, Inches	Length of Pipe, Feet							
	10	20	30	40	50	60	70	80
½	132	92	73	63	56	50	46	43
¾	278	190	152	130	115	105	96	90
1	520	350	285	245	215	195	180	170
1-¼	1,050	730	590	500	440	400	370	350
1-½	1,600	1,100	890	760	670	610	560	530

After the length of pipe has been determined, select the pipe size which will provide the minimum cubic feet per hour required for the gas input rating of the furnace. By formula:

$$\text{Cu. Ft. Per Hr. Required} = \frac{\text{Gas Input of Furnace (BTU/HR)}}{\text{Heating Value of Gas (BTU/FT}^3\text{)}}$$

The gas input of the furnace is marked on the furnace rating plate. The heating value of the gas (BTU/FT<sup>3</sup>) may be determined by consulting the local natural gas utility or the LP gas supplier.

**FIGURE 17B**  
INLET PRESSURE ("T" FITTING) TAP

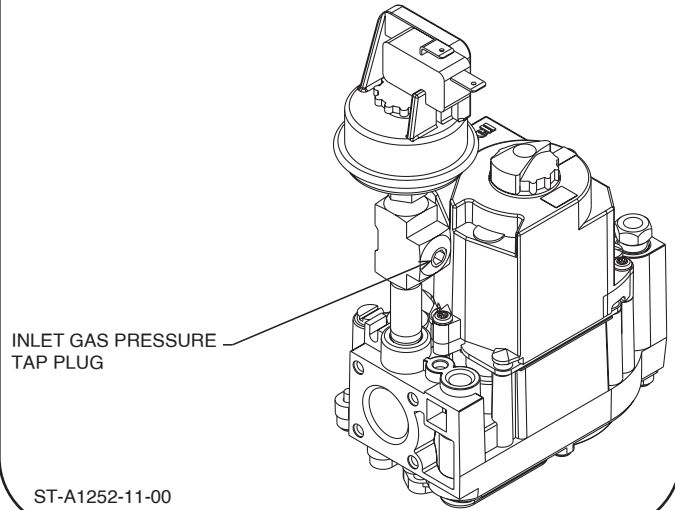

## GAS VALVE

This furnace has a 24-volt gas valve. It has ports for measuring supply and manifold gas pressure. The valve body contains a pressure regulator to maintain proper manifold gas pressure.

A control switch is on the valve body. It can be set to only the "ON" or "OFF" positions. The gas valve is a slow-opening valve. See Figures 17A and 17B.

When energized, it takes 2 to 3 seconds to fully open.

To adjust manifold pressure, insert screwdriver in top plate access holes. See Figure 17C.

**FIGURE 17C**  
MANIFOLD PRESSURE ADJUSTMENT

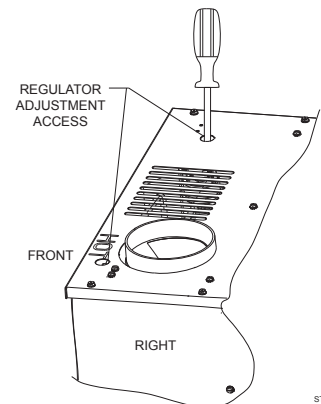

ST-A1252-24-00

# GAS SUPPLY (cont.)

## SETTING GAS PRESSURE

*The maximum gas supply pressure to the furnace must not exceed 10.5" w.c. natural gas.* The minimum supply gas pressure to the gas valve should be 59 w.c. natural gas. A properly calibrated manometer is required for accurate gas pressure measurements.

## SUPPLY GAS PRESSURE MEASUREMENT

An inlet pressure tap is on the input side of the gas valve located in a "T" between the gas valve and the gas pressure switch (Figure 17B).

1. With gas shut off to the furnace at the manual gas valve outside the unit, remove the inlet pressure tap plug from the tee.
2. Connect a manometer to the pressure tap.
3. Turn on the gas supply and operate the furnace and all other gas-fired units on the same gas line as the furnace.
4. Note or adjust the line gas pressure to give:
  - A. 69 - 10.59 w.c. for natural gas.
5. Shut off the gas at the manual gas valve and remove the manometer and hose.
6. Replace the pressure tap plug before turning on the gas.
7. Turn on the gas supply and check for gas leaks using an approved leak detector. Do **NOT** use a flame of any kind to check for leaks. Repair any leaks and repeat.

If the supply gas line pressure is above these ranges, a high pressure in line gas regulator may be required. Consult local gas utility.

If supply gas line pressure is below these ranges, either remove any restrictions in the gas supply piping or enlarge the gas pipe. See Table 6.

**NOTE:** This unit is equipped with a gas pressure switch that will not allow operation below 59 w.c. of inlet gas pressure.

**NOTE:** Pre-mix Ultra Low NOx burners (unlike conventional burners) require careful attention to purge gas lines before start-up. It is important to remove as much air from the gas line as possible before attempting to light. It may require multiple trials for ignition before successful initial ignition.

## MANIFOLD GAS PRESSURE MEASUREMENT

**Natural gas manifold pressure should be 3.5" w.c.** Only small variations in gas pressure should be made by adjusting the pressure regulator.

1. With the gas to the unit shut off at the manual gas valve, remove the MANIFOLD pressure tap plug.
2. Connect a manometer to this pressure tap.
3. Turn on the gas supply and operate the furnace (apply a heat call).
4. Note or adjust the manifold gas pressure to give:
  - A. 3.59 w.c. for natural gas (+/- .39 w.c.).
5. To adjust the pressure regulator, remove the regulator cap. (See Figures 17A, 17B and 17C.)
6. Turn the adjustment screw clockwise to increase pressure, or counterclockwise to decrease pressure.
7. Securely replace the regulator cap.
8. Shut off gas at the manual gas valve and remove the manometer and hose.
9. Replace the pressure tap plug before turning on the gas.
10. Turn on the gas supply and apply a heat call to the furnace then check for gas leaks using an approved leak detector. Do **NOT** use a flame of any kind to check for leaks. Repair any leaks and repeat.

# ELECTRICAL WIRING

## ELECTRICAL WIRING

### **▲ WARNING**

**TURN OFF ELECTRIC POWER AT FUSE BOX OR SERVICE PANEL BEFORE MAKING ANY ELECTRICAL CONNECTIONS. FAILURE TO DO SO CAN CAUSE ELECTRICAL SHOCK RESULTING IN PERSONAL INJURY OR DEATH.**

### **▲ WARNING**

**THE CABINET MUST HAVE AN UNINTERRUPTED GROUND ACCORDING TO THE LATEST EDITION OF THE NATIONAL ELECTRICAL CODE, ANSI/NFPA70 OR LOCAL CODES THAT APPLY. DO NOT USE GAS PIPING AS AN ELECTRICAL GROUND. A GROUND SCREW IS PROVIDED IN THE JUNCTION BOX. FAILURE TO DO SO CAN CAUSE ELECTRICAL SHOCK RESULTING IN PERSONAL INJURY OR DEATH.**

### **▲ WARNING**

**THIS FURNACE IS EQUIPPED WITH A BLOWER DOOR SAFETY SWITCH. DO NOT DISABLE THIS SWITCH. FAILURE TO FOLLOW THIS WARNING CAN RESULT IN ELECTRICAL SHOCK, PERSONAL INJURY OR DEATH.**

## ELECTRICAL CONNECTIONS

Before proceeding with the electrical connections, be certain that the voltage, frequency and phase corresponds to that specified on the furnace rating plate. For single furnace application, maximum over-current protection is 15 amperes.

Use a separate fused branch electrical circuit containing a properly sized fuse or circuit breaker. Run this circuit directly from the main switch box to an electrical disconnect that is readily accessible and located near the furnace (as required by code). Connect from the electrical disconnect to the junction box on the left side of the furnace, inside the blower compartment. For the proper connection, refer to the appropriate wiring diagram located on the inside cover of the furnace control box and in these instructions.

**NOTE:** The electrical junction box may be moved to the right side if necessary. A knockout is provided. Seal the opposite hole with plug provided.

**NOTE:** L1 (hot) and L2 (neutral) polarity must be observed when making field connections to the furnace. The ignition control may not sense flame if L1 and L2 are reversed. Make all electrical connections in accordance with the latest edition of the National Electrical Code ANSI/NFPA70.

These may be obtained from:

National Fire Protection Association, Inc.  
Batterymarch Park  
Quincy, MA 02269

**FIGURE 18**

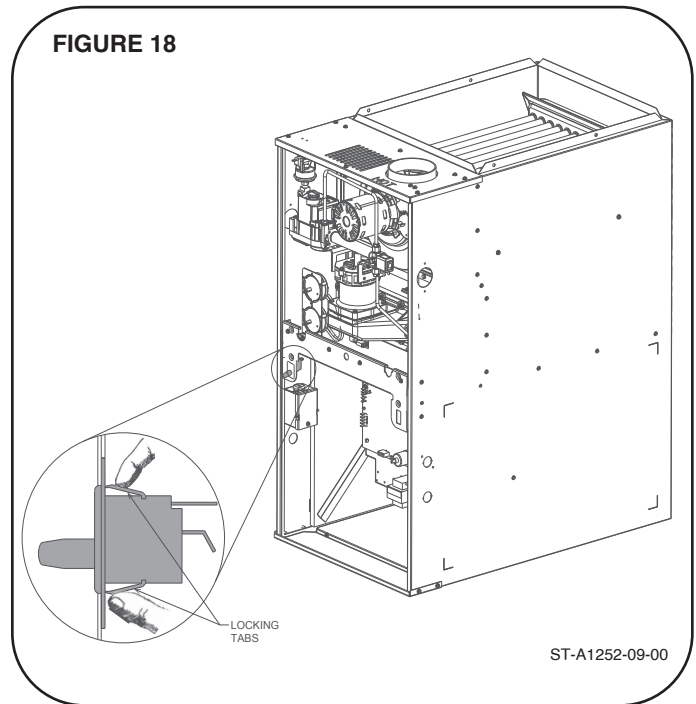

## RELOCATING THE ELECTRICAL CONNECTION (JUNCTION BOX)

**NOTE:** Relocating the junction box is not possible in 14.0 inch cabinets.

If the line voltage electrical needs to be moved to the opposite side of the furnace, the following steps should be taken:

1. The furnace must NOT be electrically connected to line voltage prior to reversing the electrical connection.
2. Disconnect the wires from the door switch.
3. Remove the junction box from the furnace cabinet wall by removing the two screws that hold it to the cabinet. Leave the wires connected to the junction box.
4. Remove 7/8" plug from hole opposite j-box location. Drill 2 @ 3/16" Ø holes in the jacket. **NOTE:** Dimples/marks are provided in the sheet metal for correct drilling location.
5. Move the junction box to the opposite side of the cabinet. Install using the two screws removed in step 3 above. Note that all screws penetrating the junction box must be blunt – no sharp tipped screws can be used.
6. Replace the plug from the opposite of the furnace (the new j-box location) to the old j-box location and install qty=2 1/4" plugs from parts bag in empty screw holes in old location of j-box into the mounting screw holes in the old junction box location.

# ELECTRICAL WIRING

## RELOCATING ELECTRICAL CONNECTION & THERMOSTAT

- Using a flat screwdriver, squeeze the retaining arms on the door switch and gently pry the door switch from its opening.
- Install the door switch in the same opening on the opposite of the furnace and reconnect the electrical connectors (removed in Step 2) to the door switch.

### THERMOSTAT

The room thermostat must be compatible with the furnace. See manufacturer's thermostat spec sheet for compatibility concerns. Generally, all thermostats that are not of the "current robbing" type are compatible with the integrated furnace control. The low voltage wiring should be sized as shown.

See: I&O Notes, Thermostat tab.

**NOTE:** Do not use 24 volt control wiring smaller than No. 18 AWG.

Install the room thermostat in accordance with the instruction sheet packed in the box with the thermostat. Run the thermostat lead wires inside the blower compartment and connect to low voltage terminals as shown on the wiring diagram. Never install the thermostat on an outside wall or where it will be influenced by drafts, concealed hot or cold water pipes or ducts, lighting fixtures, radiation from fireplace, sun rays, lamps, televisions, radios or air streams from registers.

### THERMOSTAT WIRING OPTIONS

The R801V thermostat wiring is not typical. Installer must use the ECM Interface Control (see Page 3, Furnace Components) for: AC applications - Y1 and Y2 connections.

Dual fuel applications (single-stage and two-stage) - Y1, Y2 and B connections.

**FIGURE 20**  
LINE VOLTAGE CONNECTIONS

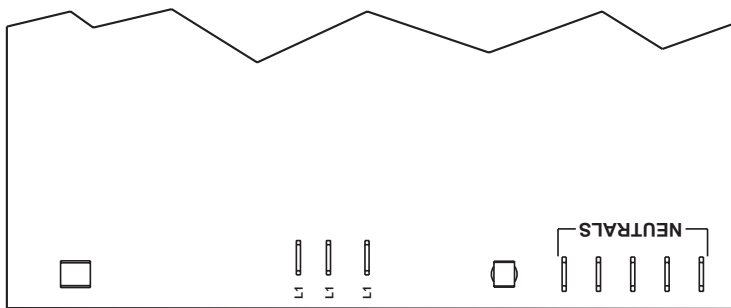

ST-A1332-03

# ELECTRICAL WIRING

## THERMOSTAT WIRING DIAGRAMS-HEAT PUMP

**FIGURE 21**

Wiring diagram for a legacy single-stage thermostat with auto-staging.

E. Air handler system with legacy thermostats.

E1. Wiring of a single-stage legacy thermostat with auto-staging selected (See Figure 21).

**FIGURE 21**

**WIRING DIAGRAM FOR A LEGACY SINGLE-STAGE THERMOSTAT WITH AUTOSTAGING.**

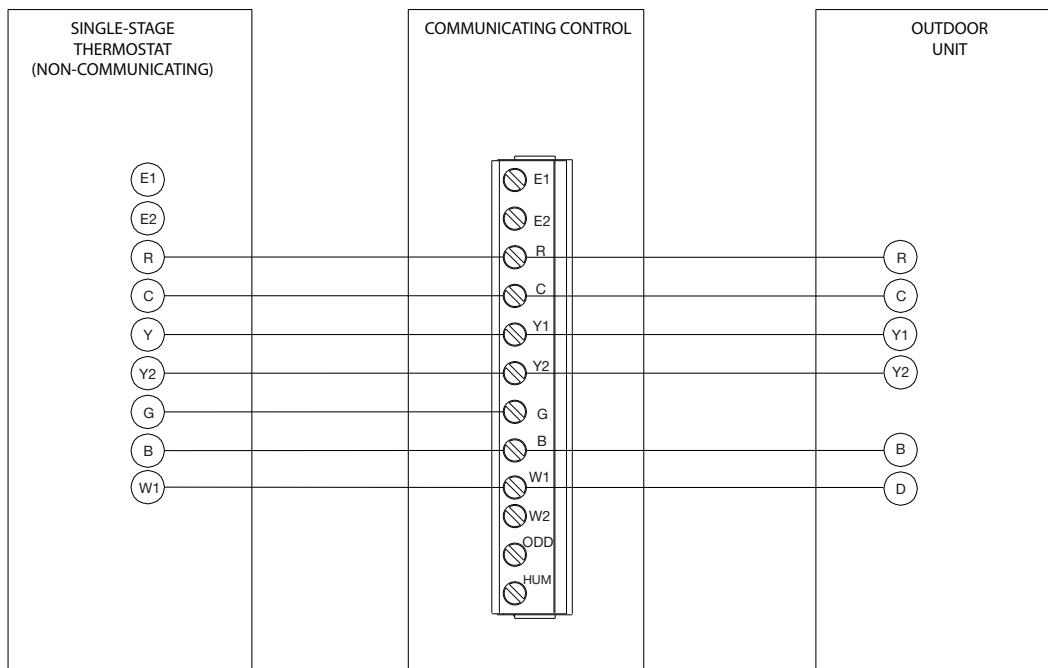

NOTE: 1.) SELECTIONS FOR TIME STAGING CAN BE MADE VIA CONTRACTOR APP WHEN CONNECTED WITH BLUETOOTH.

2.) FOR SINGLE STAGE COOLING A JUMPER BETWEEN Y1 AND Y2 IS REQUIRED.

ST-A1332-01

# ELECTRICAL WIRING

## THERMOSTAT WIRING DIAGRAMS-CONDENSING UNIT (NON-COMMUNICATING)

**FIGURE 22**

Wiring diagram for a legacy single-stage thermostat with auto-staging.

E. Air handler system with legacy thermostats.

E1. Wiring of a single-stage legacy thermostat with auto-staging selected (See Figure 22).

**FIGURE 22**  
WIRING DIAGRAM FOR A LEGACY SINGLE-STAGE THERMOSTAT WITH AUTOSTAGING.

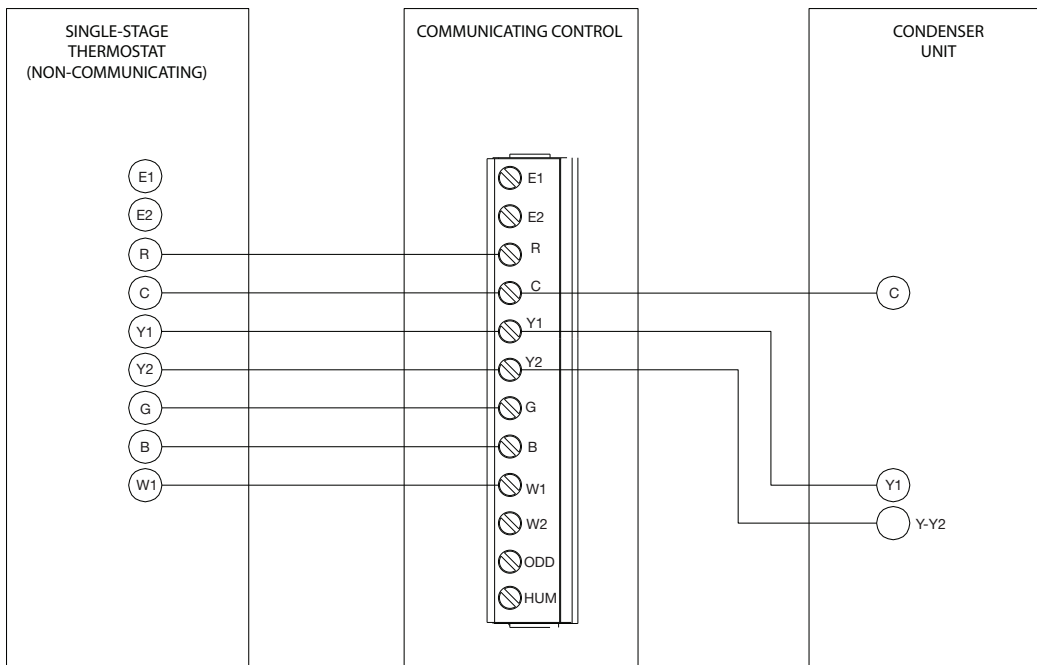

NOTE: 1.) SELECTIONS FOR TIME STAGING CAN BE MADE VIA CONTRACTOR APP WHEN CONNECTED WITH BLUETOOTH.

2.) FOR SINGLE STAGE COOLING A JUMPER BETWEEN Y1 AND Y2 IS REQUIRED.

ST-A1332-02

# ELECTRICAL WIRING

## THERMOSTAT WIRING DIAGRAMS-CONDENSING UNIT (NON-COMMUNICATING)

**FIGURE 23**

Wiring diagram for a legacy single-stage thermostat with auto-staging.

E. Air handler system with legacy thermostats.

E1. Wiring of a single-stage legacy thermostat with auto-staging selected (See Figure 23).

**FIGURE 23**  
WIRING DIAGRAM FOR A LEGACY SINGLE-STAGE THERMOSTAT WITH AUTOSTAGING.

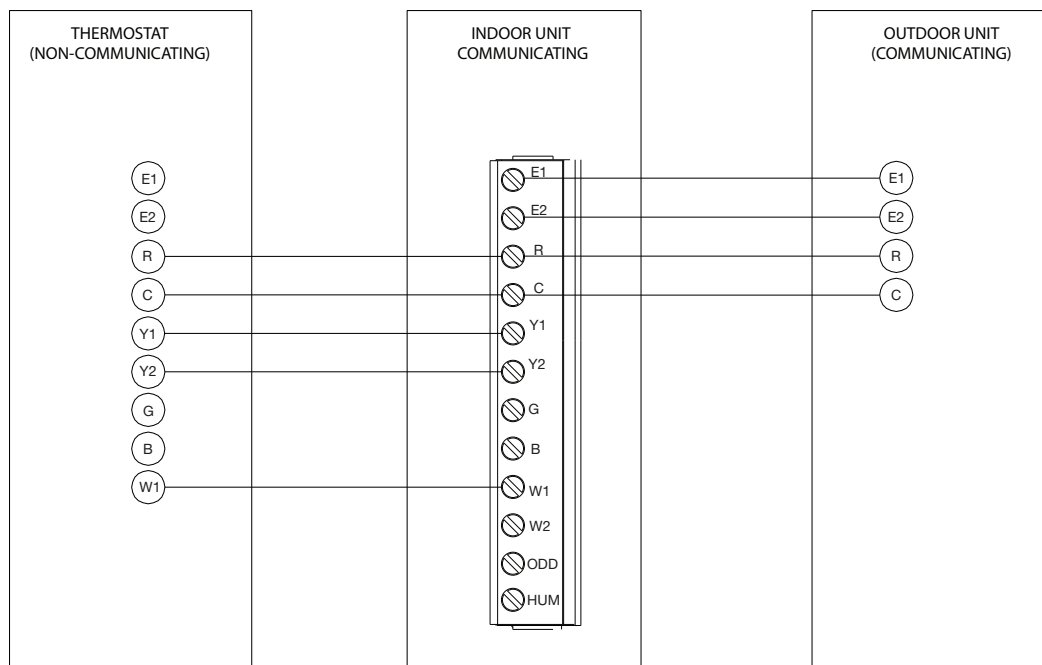

NOTE: 1.) SELECTIONS FOR TIME STAGING CAN BE MADE VIA CONTRACTOR APP WHEN CONNECTED WITH BLUETOOTH.

ST-A1332-05

# ELECTRICAL WIRING

## THERMOSTAT WIRING DIAGRAMS-CONDENSING UNIT (NON-COMMUNICATING)

FIGURE 24

Wiring diagram for a fully communicating system.

Electrical Wiring

FIGURE 24  
WIRING DIAGRAM FOR A FULLY COMMUNICATING SYSTEM.

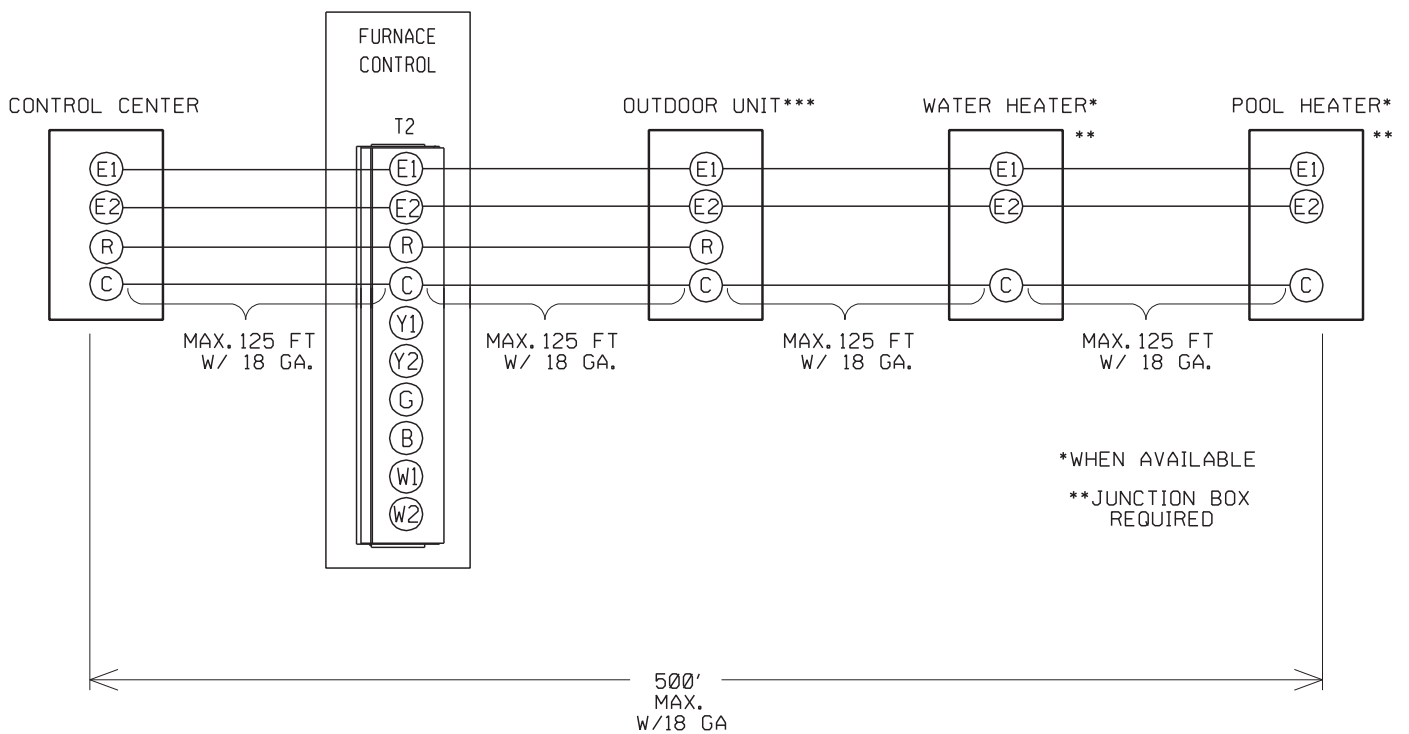

THIS IS THE ONLY APPROVED CONFIGURATION

ST-A1325-10

# ACCESSORIES

## FIELD INSTALLED OPTIONAL ACCESSORIES

### ELECTRONIC AIR CLEANER

Line voltage power can be supplied from the terminal labeled “EAC” and a line voltage neutral terminal on the control board. This will power the electronic air cleaner whenever the circulating air blower is in operation.

### HUMIDIFIER

Line voltage power is supplied from the terminal labeled “HUM” to a line voltage neutral terminal on the control board. This will power the humidifier whenever the induced draft motor is energized.

**NOTE:** Maximum current – 1.0 amps for each option (humidifier or electronic air cleaner).

### FILTERS (See Figures 25 and 26)

Keep filters clean at all times. **A filter is not provided with the furnace, but one must be field-supplied and installed.**

It is recommended to replace the furnace filter periodically to maintain optimum furnace performance.

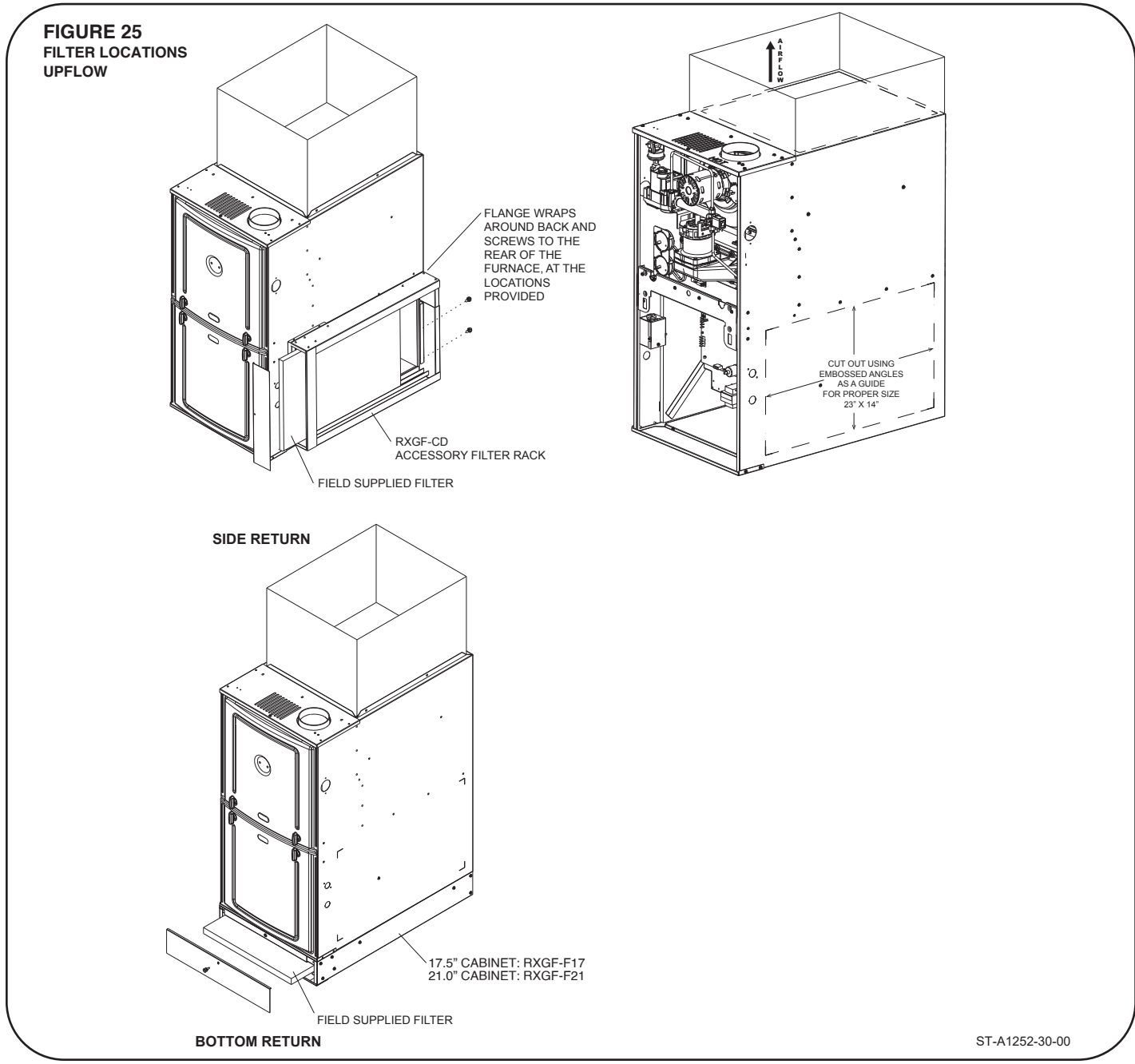

# ACCESSORIES

## FIELD INSTALLED OPTION ACCESSORIES (cont.)

Accessories

**FIGURE 26**  
HORIZONTAL FILTER KITS

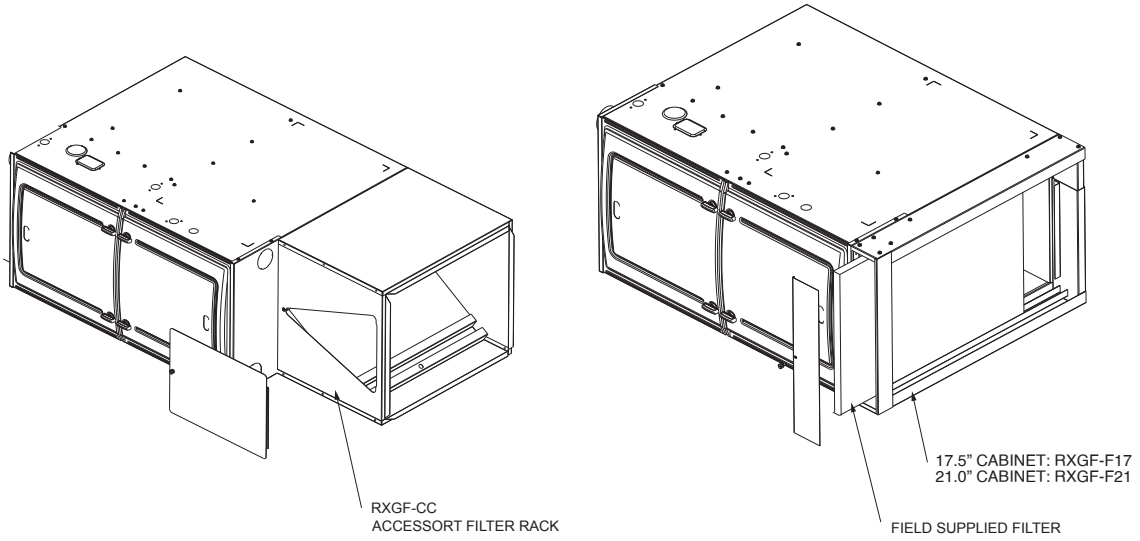

ST-A1252-22-00

# START-UP PROCEDURES

## SEQUENCE OF OPERATIONS

This furnace is equipped with an intermittent pilot control. Each time the room thermostat calls for heat, the ignitor lights the pilot which lights the burner directly. See the lighting instructions on the furnace.

### TO START THE FURNACE

1. Remove the burner compartment control access door.
2. **IMPORTANT:** Be sure that the manual gas control has been in the "OFF" position for at least five minutes. Do not attempt to manually light the main burners.
3. Turn off the furnace electrical power and set the room thermostat to its lowest setting.
4. Turn the gas control to the "ON" position or move the gas control lever to the "On" position.
5. Replace the burner compartment control access door.
6. Turn on the furnace electrical power.
7. Set the room thermostat to a point above room temperature to light the main burners.
8. After the burners are lit, set the room thermostat to a desired temperature.
9. Operate gas heat for a minimum period of 15 minutes and adjust input rate. It is important that the input to this furnace be adjusted correctly. See Section 19 for more detail.

### TO SHUT DOWN THE FURNACE

1. Set the room thermostat to its lowest setting and wait for furnace to shut down.
2. Remove the burner compartment control access door.
3. Shut off the gas to the main burners by turning the gas control to the "OFF" position.

#### **WARNING**

**SHOULD OVERHEATING OCCUR OR THE GAS SUPPLY FAIL TO SHUT OFF, CLOSE THE MANUAL GAS VALVE FOR THE APPLIANCE BEFORE SHUTTING OFF THE ELECTRICAL SUPPLY. FAILURE TO DO SO CAN CAUSE AN EXPLOSION OR FIRE RESULTING IN PROPERTY DAMAGE, PERSONAL INJURY OR DEATH.**

**NOTE:** It is important to remove as much air from the gas lines as possible before attempting to light. It may require multiple trials for ignition before successful initial ignition.

## 80+ ULN SEQUENCE OF OPERATIONS

### Learning/Calibration Cycle:

- This cycle is performed after power is cycled.
- Once every 100 heat calls.
- When the previous attempt at calibration failed.
- When the ignition or combustion pressure switch fails to close within 60 seconds during a noncalibration cycle.
- The next heat attempt after either the ignition or combustion pressure switch opens long enough to interrupt the heat cycle.

### Learning/Calibration Cycle Configuration:

A call for heat closes R and W on the control. The IFC (Internal Furnace Control) turns the IDB (Induced Draft Blower) on at 2000 RPM and then begins to ramp up 25 RPM every 4 seconds until the ignition pressure switch closes then adds 300 RPM and saves this value as the "Ignition Speed." The IFC then continues to ramp up the IDB speed 25 RPM every 4 seconds until the combustion pressure switch closes. The IFC then drops the IDB speed 25 RPM every 2.5 seconds until the combustion pressure switch opens then adds 500 RPM and saves this value as the "Cold Heat Speed." The IDB then steps up to the "Cold Heat Speed."

After 25 seconds of operation at the "Cold Heat Speed" the IFC drops the IDB speed back down to the "Ignition Speed." After operating at the "Ignition Speed" for 10 seconds the IFC proceeds to the "Trial for Ignition." During the "Trial for Ignition" the IFC energizes the gas valve pilot solenoid. One second later the external solenoid and sparker are energized. (The PSLD stays energized for 4 seconds after the main gas valve is energized.) When flame is sensed the IFC de-energizes the sparker. Gas valve pilot solenoid and the PSLD remain energized. Once flame has been present for 2 seconds the main valve opens and the IFC starts to slowly ramp the IDB speed back up to the "Cold Heat Speed" within 120 seconds. The indoor blower comes on 20 seconds after the main gas valve is energized.

After 2 minutes the IFC performs a warm calibration. The IFC starts to drop the IDB speed 25 RPM every 2.5 seconds until the combustion pressure switch opens. Once the combustion pressure switch opens the IFC increases the IDB speed back up until the combustion pressure switch closes then adds 400 RPM and saves this value as the "Warm Heat Speed."

### Noncalibration Cycle "Normal Heat Cycle":

A call for heat closes R and W on the IFC. The IFC turns on the IDB at the "Cold Heat Speed" and confirms that the ignition pressure switch and combustion pressure switch are closed.

After 25 seconds of operation at the "Cold Heat Speed" the IFC drops the IDB speed back down to the "Ignition Speed." After running at the "Ignition Speed" for 10 seconds the IFC proceeds to the "Trial for Ignition." During the "Trial for Ignition" the control energizes the gas valve pilot solenoid. One second later the PSLD and sparker are energized. (The PSLD stays energized for 4 seconds after the main gas valve is energized.) When flame is sensed the IFC de-energizes the sparker. Gas valve pilot solenoid and the PSLD remain energized. Once flame has been present for 2 seconds the main valve opens and the IFC starts to slowly ramp the IDB speed back up to the "Warm Heat Speed" within 120 seconds. The indoor blower comes on 20 seconds after main gas valve is energized.

### Hot Ignition Sequence:

If a call for heat or fault recycle is made within 10 minutes of termination of the previous heat cycle the IDB and the main blower will be energized for a 2 minute cool down period prior to the non-calibration cycle above.

### Power Interruption:

If main power is interrupted the IDB and main blower will be energized for a 2 minute period prior to the learning cycle above.

# INTEGRATED FURNACE CONTROL

## HUMIDIFICATION/DEHUMIDIFICATION

An optional 24VAC humidistat can be installed as shown in Figures 30 thru 33. With the optional humidistat, two separate conditions must be met before humidification can begin 1). There must be a call for heat and the blower must be engaged and 2.) The humidistat must determine that there is a need for humidification. Note: Enable humidification/dehumidification via Bluetooth app. However, it has no affect on humidification operation. If this switch is set to the "ON" position and no humidistat is installed, the cooling airflow will be permanently reduced by approximately 15% giving less than optimal performance and possibly causing problems. It is not recommended to leave this switch in the "ON" position without a humidistat installed.

Control of dehumidification in cooling and/or humidification in heating can be done with a variety of methods depending on whether there is a communicating thermostat or a humidistat available and depending on the type of operation desired.

With systems configured with communicating thermostats and condensers, dehumidification is controlled by the thermostat. To determine which wiring diagram and method to use, select from the following configuration:

### A. HUMIDIFICATION CONTROL ONLY WITH NO DEHUMIDIFICATION (REQUIRES OPTIONAL HUMIDIFIER).

#### A1. WITH COMMUNICATING THERMOSTAT

Humidifier control is included with EcoNet communicating thermostats. To wire the furnace for humidification control using an EcoNet communicating thermostat, refer to the wiring diagram in Figure 29. Be sure not to install the jumper between "R" and "HUM

STAT" on the furnace control. Installing this jumper will operate the humidifier any time there is a heat call. Without the jumper, the humidification call from the thermostat must be active and a heat call must be present with the blower running.

#### A2. WITH NON-COMMUNICATING THERMOSTAT

##### A2-1 CONTINUOUS HUMIDIFIER OPERATION DURING HEATING.

For continuous humidifier operation during heating, refer to Figure 29 and make sure to install the jumper between the thermostat terminals labeled "R" and "HUM STAT".

A separate humidistat is not required for this configuration and the humidifier will turn on whenever there is a call for heat and the blower is running.

##### A2-2 CONTROLLED HUMIDIFIER OPERATION USING A HUMIDISTAT (REQUIRES OPTIONAL HUMIDISTAT).

Controlled humidification can be accomplished using a humidistat as shown in Figures 31 or 32. These figures show installation of a humidifier with external and internal power supplies respectively. Dehumidification will be enabled via Bluetooth app.

### B. DEHUMIDIFICATION CONTROL WITH NO HUMIDIFICATION

#### B1. WITH COMMUNICATING THERMOSTAT

For communicating thermostats listed with this furnace, dehumidification is controlled automatically when selected at the thermostat and additional wiring is not necessary. The actual airflow demand (reduced for dehumidification) is requested of the furnace by the thermostat.

#### B2. WITH NON-COMMUNICATING THERMOSTAT (REQUIRES OPTIONAL HUMIDISTAT)

Control of dehumidification only (no humidification) can be accomplished by installing an optional humidistat as shown in Figure 32. If dehumidification is enable via Bluetooth app with no humidistat airflow will be reduced by approximately 15%.

### C. HUMIDIFICATION AND DE-HUMIDIFICATION CONTROL (REQUIRES OPTIONAL HUMIDIFIER).

#### C1. WITH COMMUNICATING THERMOSTAT

Humidifier control is included with EcoNet communicating thermostats. To wire the furnace for humidification and dehumidification control using an EcoNet communicating thermostat, refer to the wiring diagram in Figure 21 Option A. Be sure not to install the jumper between "R" and "HUM STAT" on the furnace control for thermostat controlled option. Without the jumper, a humidification call from the thermostat must be active and a heat call must be present with the blower running for the "HUM" relay contacts to close.

Installing this jumper between "R" and "HUMSTAT" as shown in Figure 21 Option B will operate the humidifier any time there is a heating call. Dehumidification will never take place when in cooling. This option can be used for communicating and noncommunicating thermostats.



# INTEGRATED FURNACE CONTROL

**FIGURE 29**  
**WIRING FOR OPTIONAL DE-HUMIDIFICATION AND HUMIDIFICATION WITH OPTIONAL HUMIDIFIER (HUMIDIFIER WITH INTERNAL POWER SUPPLY).**

NOTE: FOR USE WITH NON-COMMUNICATING SYSTEMS.

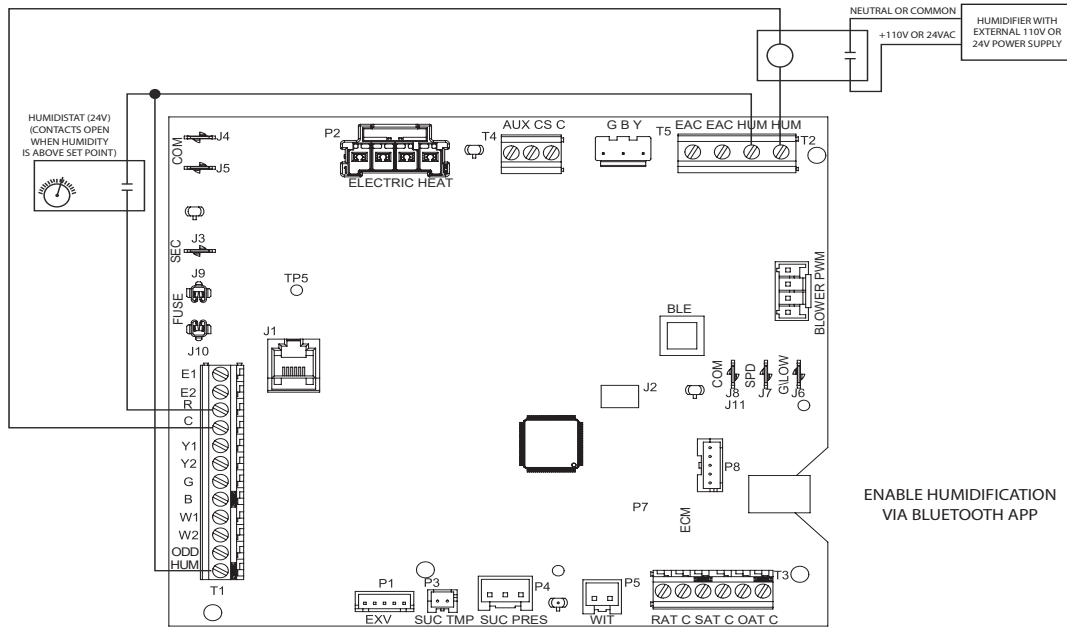

ST-A1336-25-00

**FIGURE 30**  
**HUMIDISTAT USED TO CONTROL DEHUMIDIFICATION IN COOLING ONLY (NO HUMIDIFIER).**

NOTE: FOR USE WITH NON-COMMUNICATING THERMOSTATS.

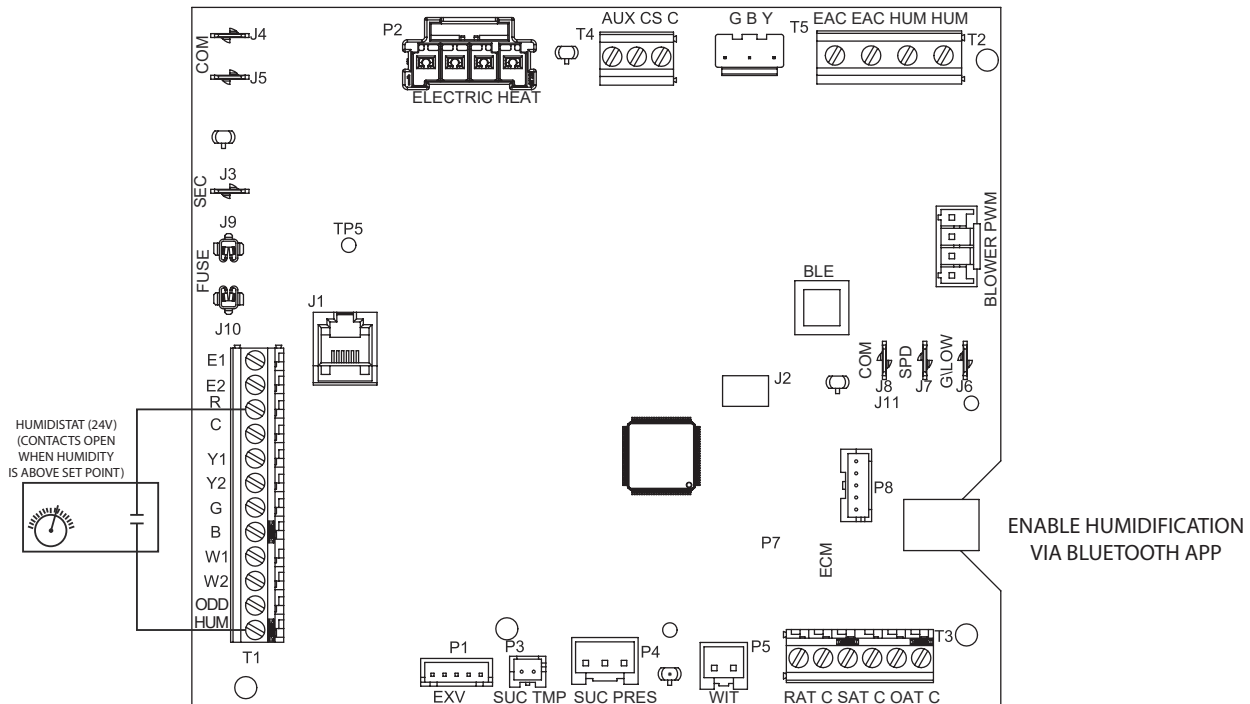

ST-A1336-26-00

# INTEGRATED FURNACE CONTROL

## SUPPLY & OUTDOOR AIR TEMPERATURE SENSORS

### 1. P1 (4-Pin), P2 (7-Pin) and P5 (5-Pin) - Low-Voltage Internal Wiring

Connections – Connect main twistlock wire harness to these connections. Pre-wired from the factory.

### 2. RJ-11 CONNECTOR (J1)

#### **WARNING**

**DO NOT CONNECT A TELEPHONE OR PHONE LINE TO THE CONNECTOR (JACK) AT POSITION J-11. DOING SO COULD CAUSE IRREPARABLE DAMAGE TO EITHER THE FURNACE CONTROL (I.F.C.) OR THE TELEPHONE (OR TELEPHONE LINE) OR BOTH.**

This connector is used to program the furnace control at the factory. It should never be connected to a telephone line or a telephone. Doing so could damage the furnace control or the telephone (or telephone lines) or both.

### 3. SPARK IGNITION TRANSFORMER (T1)

The spark ignition transformer resides on the furnace control. The transformer provides spark energy at approximately 60 hz frequency and a minimum of 12KV.

### 4. LINE VOLTAGE CONNECTIONS (120VAC, L1)

¼" Quick-Connect style terminals are provided for internal connections and accessories.

### 5. INDUCED DRAFT MOTOR (INDUCER) OUTPUT (P3)

This three-pin Mate-n-Lok style connector provides power to both the high and low speed inducer outputs.

### 6. NEUTRAL TERMINALS (N)

Five ¼" Quick-Connect style terminals are provided for internal connections and accessories.

### 7. 24VAC AND COMMON CONNECTIONS (Com/CC)

For connection to the low voltage side of the control transformer. Terminals are ¼" quick-connect style.

### 8. EXV

Connector provided for Evap. Coils equipped with an EXV control.

### 9. SUC. PRESS

Connector provided for Evap. Coils equipped with an EXV Control System.

### 10. FUSE

A fuse is provided to protect low-voltage (24VAC) circuits from shorts between 24VAC and Ground or Common. A fault code 30 is reported via Bluetooth app when the fuse has been opened.

### 11. ELECTRONIC AIR CLEANER (E.A.C.) OUTPUT (T3)

This output is used to energize an electronic air cleaner. The output will provide 1.0 amp at 115 VAC. This output is energized any time the blower motor is above the airflow CFM values specified below. Airflow below this value is not considered to be enough for a typical electronic air cleaner to perform properly.

For ½ HP motors - Electronic air cleaner is energized any time the blower is above 500 CFM

For ¾ HP motors - Electronic air cleaner is energized any time the blower is above 600 CFM

For 1 HP motors - Electronic air cleaner is energized any time the blower is above 700 CFM

Some lower fan speeds may not deliver enough airflow to operate an electronic air cleaner. The IFC determines the minimum airflow necessary to operate an electronic air cleaner and will not turn on the electronic air cleaner unless the airflow is high enough for the EAC.

### 12. HUMIDIFICATION (T3) AND DEHUMIDIFICATION

**HUMIDIFIER** – The humidifier contacts (labeled “HUM” (2)) are “dry” contacts on the I.F.C. This means that the terminals are connected directly to the contacts of a board-mounted relay. The coil of the relay is controlled by the microprocessor of the IFC. The coil is engaged roughly any time the heat speed blower is engaged and (1) 24VAC is present on the thermostat terminal of the IFC labeled “HUM STAT” or (2) a communicating thermostat with humidification and dehumidification capability is installed with call for humidification present. (See Figure 28 for location of humidification/ dehumidification inputs on furnace control.)

# INTEGRATED FURNACE CONTROL

## SUPPLY & OUTDOOR AIR TEMPERATURE SENSORS

### 13. SUPPLY AND OUTDOOR AIR TEMPERATURE

#### SENSOR INPUTS (T4)

Optional field installed supply air SA1, SA2 outdoor air sensors (10K NTC thermistor) shall be read from the T4 screw terminal block.

Control to resolve temperature within  $\pm 2^{\circ}\text{F}$  at  $70^{\circ}\text{F}$ . There is to be an automatic detection of the supply and outdoor air sensors. If the resistance between the terminals is within a valid 10K thermistor range (supply air temp range =  $-40^{\circ}\text{F}$  to  $200^{\circ}\text{F}$ , outdoor air temp range =  $-40$  to  $200^{\circ}\text{F}$ ), both sensors temperatures will be accessible.

If the resistance between the supply air terminals is determined to be out of range to a high resistance, it shall be interpreted as an uninstalled supplied air sensor and shall not cause an error condition unless a valid thermistor value was previously sensed on the same power cycle. If the sensor was determined to be present and then is opened the control should display a fault code. The app will report a fault code for 3 minutes and will not inhibit furnace operation. Also, if the resistance between the terminals is determined to be out of range to a low resistance and a valid thermistor value was sensed on the same power cycle, a fault code is to be

displayed on the seven segment displays. If the resistance between the outdoor air terminals (OAT) is determined to be out of range to a high resistance, it shall be interpreted as an uninstalled supplied outdoor air sensor and shall not cause an error condition unless a valid thermistor value was previously sensed on the same power cycle. If the sensor was determined to be present and then is opened the control should display a fault code. The app will report a fault code for 3 minutes and will not inhibit furnace operation.

Also, if the resistance between the terminals on the OAT is determined to be out of range to a low resistance, a fault code is to be displayed via Bluetooth app only if a valid thermistor value was previously sensed on the same power cycle.

Fault codes shall only be present for three minutes after the fault is detected. After three minutes has expired, the fault will no longer be set even if the condition creating the fault is still present. These faults are also only logged into the fault buffer one time. Should the sensor error later clear and then appear again the same sequence as noted previously will be repeated.

Communicating Furnace

FIGURE 31

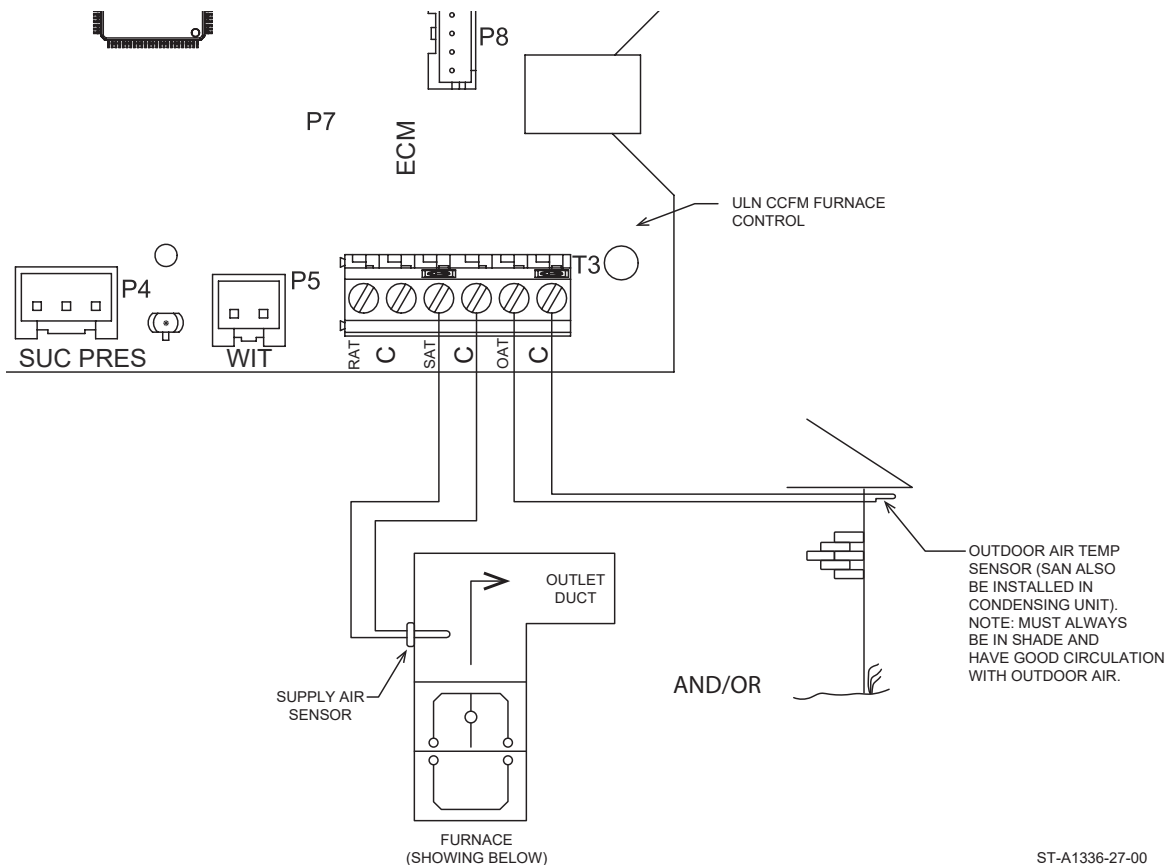

ST-A1336-27-00

# INTEGRATED FURNACE CONTROL

## AUXILIARY INPUTS

### 14. AUXILIARY INPUTS (COMMUNICATING SYSTEMS ONLY) (T4) (SEE FIGURE 32)

Terminal T4 is provided for field installation of up to two auxiliary switches. The auxiliary inputs shall be used for smoke detectors, freeze switches, etc. The inputs are to be labeled CS (Condensate Switches).

CS input shall be used to provide a mean of using traditional drain pan switches. One or both inputs can be configured at the communicating thermostat as either normally-opened or

normally closed contacts. System operation when the contacts either open or close can be configured at the communicating thermostat.

A resistance of greater than 1k ohms to common shall be detected as an open switch and a resistance of less than 100 ohms shall be recognized as a closed switch.

FIGURE 32

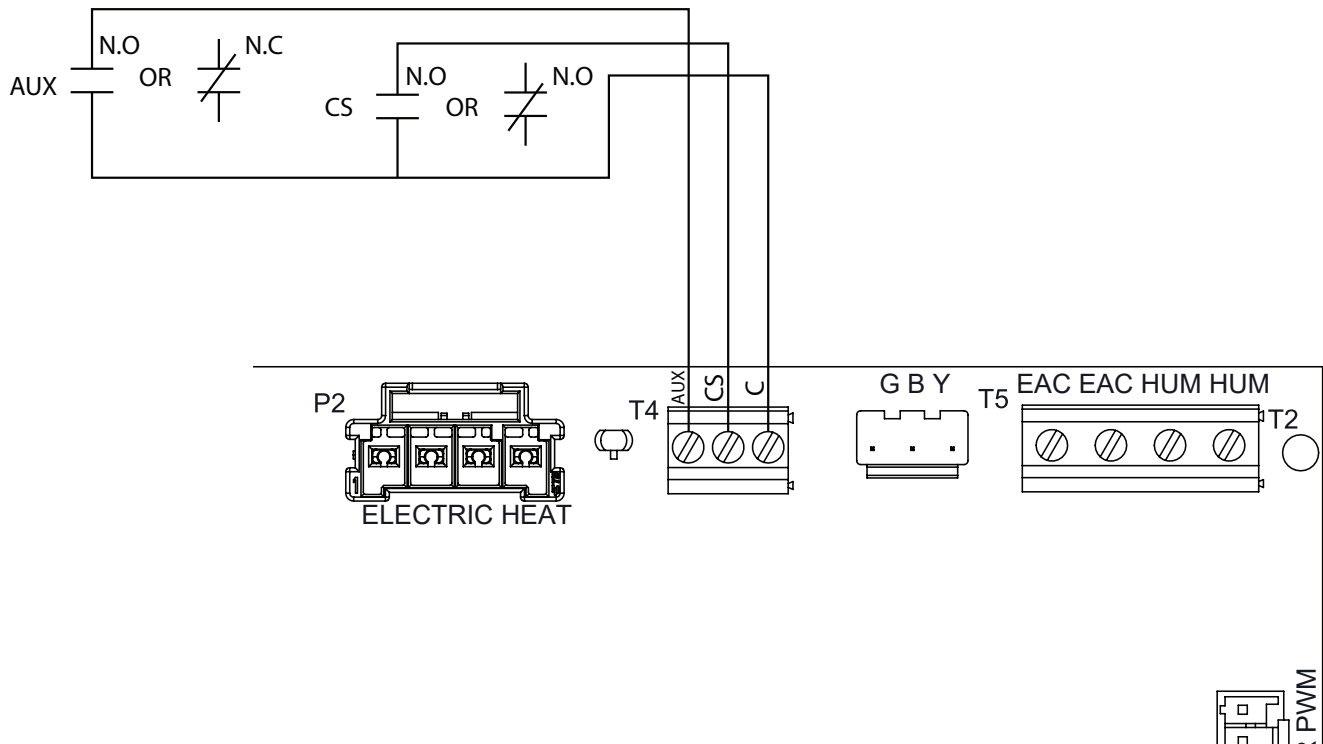

ST-A1336-28-00

# TIMING DIAGRAM

On this page are timing diagrams for heat sequences. These diagrams assume no faults are present during the heat call.

**TABLE 7**  
80+ ULN CALIBRATION CYCLE

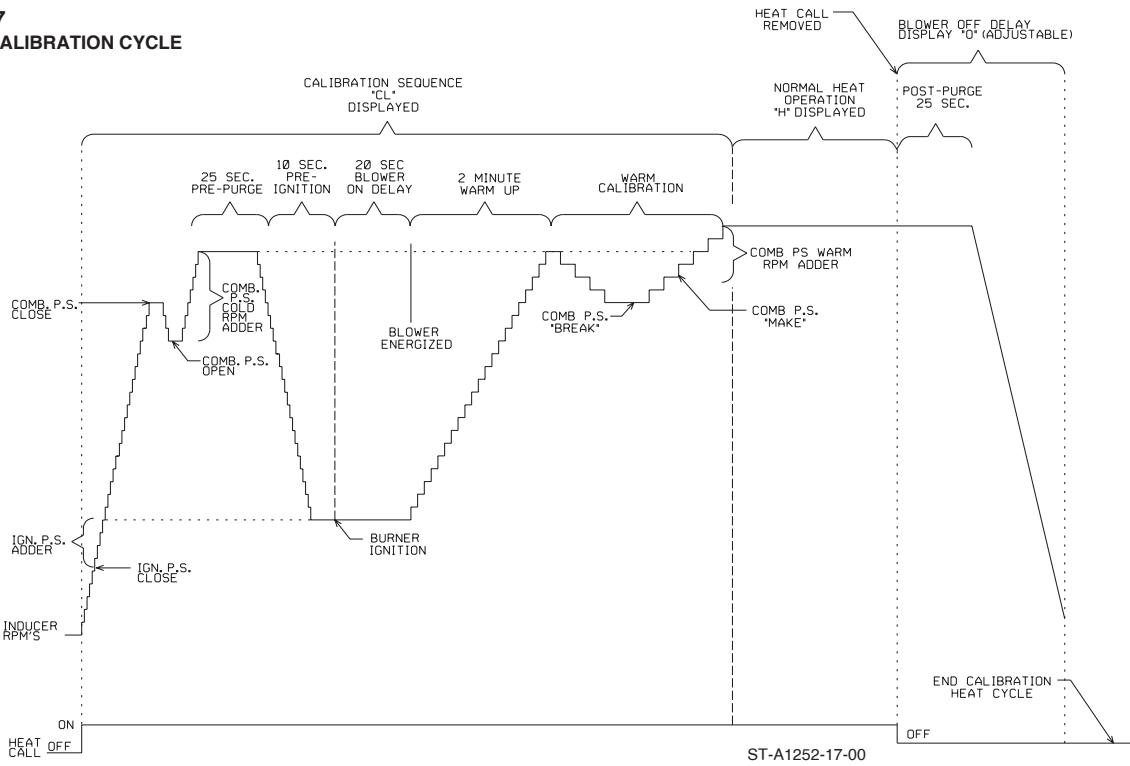

**TABLE 8**  
80+ ULN NORMAL HEAT CYCLE

NOTE:  
IF A CALL FOR HEAT IS MADE WITHIN 10 MINUTES OF TERMINATION OF THE PREVIOUS HEAT CYCLE, THE IDB AND MAIN BLOWER WILL BE ENERGIZED FOR A 2 MINUTE COOL DOWN PERIOD PRIOR TO THIS NORMAL HEAT SEQUENCE.

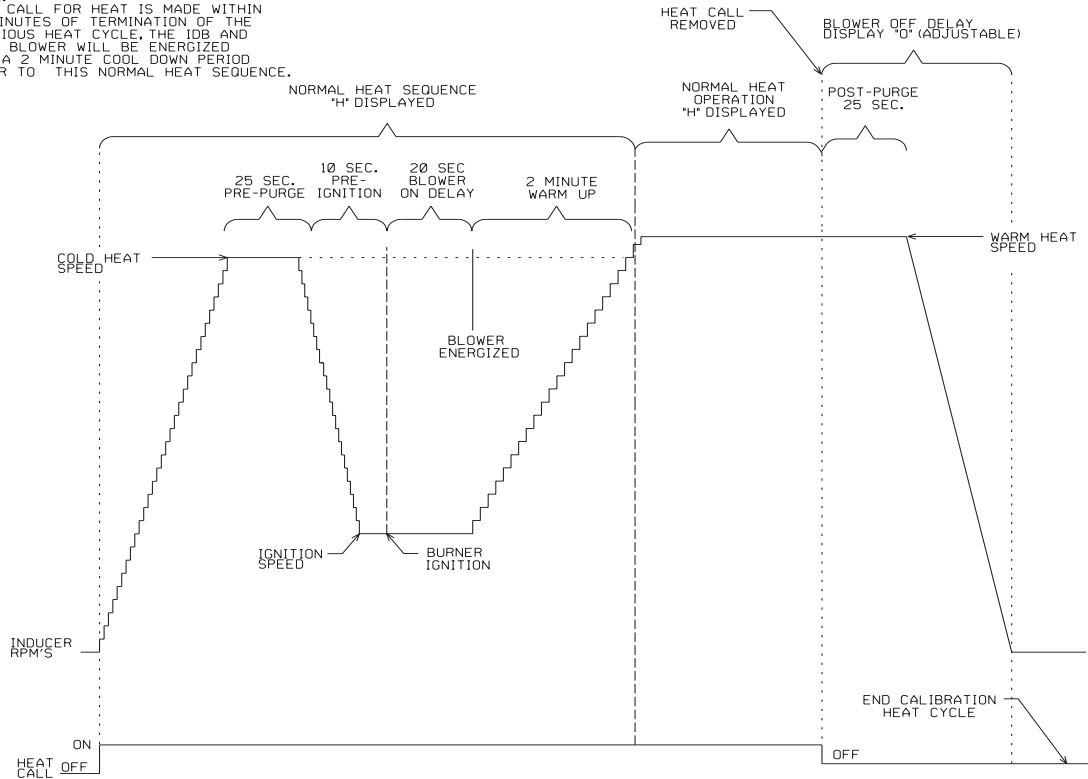

# FIELD SELECTIONS & ADJUSTMENTS

## FIELD ADJUSTMENTS

**NOTE:** For systems that are NOT fully communicating, Bluetooth connection and the contractor app will be required for proper airflow selections. Locate the QR Code on the exterior of the furnace and download the contractor app.

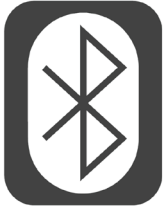

**Note:**  
For detailed fault codes and troubleshooting locate the QR code on the gas furnace to download the contractor app.

### 1. Outdoor Unit Stages:

Select the Outdoor unit number of stages. If it is connected to a single stage Outdoor unit, select 1. If the furnace is connected to a two stage Outdoor unit, select 2.

### 2. Outdoor Unit Tonnage:

Select the Outdoor unit size. A higher tonnage means the outdoor unit has a bigger capacity.

### 3. Airflow Trim:

Select airflow trim percent will increase performance either on cooling or heating.

### 4. High Gas Heat Rise:

Factory Setting = Value Specified on Rating Label.

Side return = Recalibrates motor for side return.

Approx. +7°F = Decreases Airflow by approximately 13% to achieve approximately +7°F temperature-rise.

Approx. +12°F = Decrease Airflow by approximately 20% to achieve approximately +12°F temperature-rise.

Approx. +12°F = Decrease airflow by approximately 24% to achieve approximately +12°F temperature-rise.

### 5. EXV Superheat Setpoint. (This only shows up if the control board shows the EXV input is enabled):

EXV uses inputs from suction line thermistor and suction pressure transducer to precisely calculate suction superheat and makes necessary adjustments to the refrigerant flow through the EXV to maintain the optimum superheat level. The set point is the most efficient setpoint for each coil as the factory default, however, a range is provided to further optimize for different installations.

### 6. HP/ Cooler Blower Off Delay:

This is the time that the blower would keep engaged after a heat pump or a cooling call is removed.

**7. Thermostat Heat Stage Type:** Select 1 if wiring to a single stage thermostat. Select two if wiring to a two-stage thermostat.

### 8. On-Demand Dehumidification:

This will enable or disable dehumidification feature. Make sure On Demand Dehumidification is wired on the control board.

### 9. AC Blower Airflow Reduction (This only shows if ODD is enabled above):

If On-Demand Dehumidification is enabled, this will allow a selection by percentage to reduce airflow while cooling to bring down indoor humidity. Please note, if -10% airflow trim was selected above, this will cause more reduction.

# FAULT CODES

**Note:**

For detailed Fault Code and trouble-shooting information download contractor app and scan QR code on furnace.

## FAULT CODES

### DIAGNOSTICS AND FAULT CODES

All furnace controls come standard with a 7-segment diagnostic display. During standby mode with no fault codes present, the display will read “0” (zero). During normal thermostat heating, cooling or continuous fan operation, a letter will be displayed to describe the mode of operation as follows:

H = Gas Heating Operation

When the control senses a fault present, it will display a code to help in diagnoses. A list of normal operating codes and potential fault codes follows:

The method for displaying a two-digit fault is to display the first (most significant) digit for one second immediately followed by the second digit – which is also displayed for a duration of one second. A ½ second pause is then displayed. Cycle repeats until the fault is cleared. Each fault is flashed (displayed) a minimum of two times even if the fault condition has cleared before the fault can be displayed twice.

### DUAL FAULTS DISPLAYED

In some cases when two faults are present simultaneously, both faults are displayed. These exceptions for dual faults are noted below.

Sequence of display:

- A. The first two-digit fault will be displayed once as described above.
- B. The upper-most horizontal segment of the seven-segment display is energized for ½ second.
- C. The second two-digit fault is displayed once as described above.
- D. The upper-most horizontal segment of the seven-segment display is energized for ½ again.

This cycle repeats until one fault is gone (in which case the remaining fault will be displayed as described above) or both faults are gone or otherwise as noted below:

1. When a failed ignition has occurred four times in a row, the control enters one-hour lockout and fault codes “10” and “11” will be displayed alternately as described above.
2. When flame is lost five times in a row, the control enters one-hour lockout and fault codes “10” and “13” will be displayed alternately as described above (A-D).
3. While the control is in one-hour lockout due to an unexpected flame, the fault codes “14” (unexpected flame) and “10” (soft lockout) will be displayed alternately at the seven-segment display as described above (A-D).
4. While the control has entered a one-hour lockout after declaring a dead blower after the main limit control has been open for more than 150 seconds, the fault codes “61” (Non-operational blower) and “10” (soft lockout) will be displayed alternately as described above (A-D). Note: the dead blower fault and associated one-hour lockout will occur up to four times in one heat call. Upon declaring this fault for the fourth time in one heat call, the control will enter hard lockout.
5. When the main limit has been open during a gas heat call for more than 150 seconds and has not yet re-closed, the fault codes “61” (Non-operational blower) and “22” (open limit) will be displayed alternately as described above (A-D) until the limit re-closes.

The higher priority fault code will be displayed until the condition is corrected then the lower priority fault code will display (provided the fault condition is still present).

DISPLAY CODES		
Priority	Fault Code	Description
29	0	Standby
28	F	Call for Continuous fan present
25	CL	Inducer speed calibration running
19	10	1 Hour Lockout
21	11	Failed Ignition
23	12	Low Flame Sense
24	13	Flame Lost
7	14	Unexpected Flame
10	22	Main / Aux Limit Open
22	26	L1 and Neutral reversed
8	33	Rollout switch open
12	34	Induced Draft Motor overcurrent
30	42	Flame LED not Detected
16	43	Ignition Pressure Switch closed when should be open
14	55	Combustion Pressure Switch closed when should be open
17	56	Ignition Pressure switch open when should be closed
15	57	Combustion Pressure Switch open when should be closed
18	58	Water sensor jumper not attached
20	61	Blower Fault
13	71	Inducer Fault
11	74	Gas Inlet Pressure switch open
9	75	Venturi Air Inlet Pressure switch open
1	93	Control fault

**Note 1:** Multiple fault scenarios are displayed by priority. A lower number indicates a more critical fault. Most critical fault has priority=0.

92-104632-06-03

Fault Codes



**Note:**

For systems that are not fully communicating, Bluetooth connections and the contractor app will be required for proper airflow selections. Locate the QR code on the exterior of the furnace and download the contractor app.

# 1-STAGE LOCKOUT

## LOCKOUT

All lockout conditions can be cleared immediately provided that the original fault causing the lockout is cleared and power to the unit is cycled off and then back on again or (soft lockout only) if a heat call is cycled off for greater than 2 seconds but less than 20 seconds.

The IFC will not initiate a heat cycle during any lockout condition.

### FIVE-MINUTE LOCKOUT

A five minute “soft” lockout will be initiated if the low pressure switch fails to close after 60 seconds of continuous inducer operation at the beginning of a normal heat cycle (pressure switch proving period). The seven-segment display will display the appropriate fault. Lockout will automatically be reset after five minutes.

### ONE-HOUR LOCKOUT

A one hour “soft” lock out will be initiated when:

- Flame has not been detected after four ignition trials.
- Flame has been lost for five times in one heat call.
- Undesired flame has been detected. The one-hour period will commence after flame is no longer detected.
- Dead Blower has been detected (main limit circuit open for more than 150 seconds)
- When voltage has unexpectedly been detected on the gas valve circuit and voltage goes away when inducer is shut off.

The seven-segment display will alternately display “10” and the code number for the fault causing the lockout. Lockout will automatically be reset after one hour.

### HARD LOCKOUT

Three conditions shall cause a hard lockout:

1. The control senses an unspecified internal fault. Fault code “93” is set and displayed. This lockout condition cannot be reset by cycling the heat call.
2. Voltage is detected unexpectedly on the gas valve contacts (welded relay) and will not clear by cycling the inducer. Fault code “93” is set and displayed. This lockout condition cannot be reset by cycling the heat call.
3. The furnace control will declare that the blower motor is inoperable (dead) if the main limit control has been open for more than 150 seconds. Gas heating is terminated. However, the control continues to try to operate heating for up to four attempts in case the blower motor starts working again. If a dead blower has been declared four times in one heat call, the furnace control enters a hard-lockout. Fault code “61” is set and displayed. This lockout condition **CAN** be reset by cycling the heat call.

**TABLE 9**  
**FAULT CODES WITH DESCRIPTIONS AND SOLUTIONS**

<b>FAULT CODE DISPLAYED AT SEVEN-SEGMENT DISPLAY OF CONTROL</b>	<b>DUAL FAULTS DISPLAYED</b>
	The method for displaying a two-digit fault is to display the first digit (most significant) digit for one second immediately followed by the second digit - which is also displayed for a duration of one second. A 1/2 second pause is then displayed. Cycle repeats until the fault is cleared. Each fault is flashed (displayed) a minimum of two times even if the fault condition has cleared before the fault can be displayed twice.
	A. The first two-digit fault will be displayed once as described above
	B. The upper-most horizontal segment of the seven segment display is energized for 1/2 second
	C. The second two-digit fault is displayed once as described above
D. The upper-most horizontal segment of the seven segment display is energized for 1/2 second again	

**NORMAL OPERATION CODES**

<b>0</b>	<b>STANDBY MODE</b>
	<b>DESCRIPTION:</b> This code is displayed anytime there is no fault present and no thermostat call present. The furnace is idle
<b>H</b>	<b>GAS HEAT MODE</b>
	<b>DESCRIPTION:</b> This code is displayed anytime there is a call for gas heat.
<b>CL</b>	<b>CALIBRATION MODE</b>
	<b>DESCRIPTION:</b> This code is displayed at initial heat call following power up and every 100 cycles after that to calibrate the inducer speed

**FAULT CODES**

<b>10</b>	<b>ONE-HOUR LOCKOUT</b>
	<b>STATUS:</b> This is a critical fault. The furnace will not operate in gas heat modes but all other modes (e.g. cooling) should function.
	<b>DESCRIPTION:</b> This fault is displayed under the following conditions:
	1. When a failed ignition has occurred four times in a row, the control enters one-hour lockout and fault codes "10" and "11" will be displayed alternately at the seven-segment display. See fault code 11 for a description on expected operation, causes and solutions for this fault code.
	2. While the control has entered a one-hour lockout after declaring a dead blower after the main limit control has been open for more than 150 seconds, the fault codes "61" (Non-operational blower) and "10" (soft lockout) will be displayed alternately at the seven-segment display. Note: the dead blower fault and associated one-hour lockout will occur up to four times in one heat call. Upon declaring this fault for the fourth time in one heat call, the control will enter hard lockout requiring manual reset of power to the furnace. See fault code 61 for a description on expected operation, causes and solutions for this fault code.
	3. When IFC is in soft lockout and fault "93" is active, the fault code "93" is to be displayed alternately with the fault code "10" at the furnace seven-segment display. See fault code 93 for a description on expected operation, causes and solutions for this fault code.
	4. When flame is lost five times in a row, the control enters one-hour lockout and fault codes "10" and "13" will be displayed alternately at the IFC seven-segment display. See fault code 13 for a description on expected operation, causes and solutions for this fault code.
5. While the control is in one-hour lockout due to an unexpected flame, the fault codes "14" (unexpected flame) and "10" (soft lockout) will be displayed alternately at the furnace seven-segment display. See fault code 14 for a description on expected operation, causes and solutions for this fault code.	

**TABLE 9**  
**FAULT CODES WITH DESCRIPTIONS AND SOLUTIONS**

<b>11</b>	<b>FAILED IGNITION</b>
	<p><b>STATUS:</b> Up to three failed ignitions will not constitute a critical condition. Critical condition (with no heating operation) is only noted when the furnace has failed to ignite four or more times consecutively. After four failed ignition attempts, the IFC enters one-hour lockout and the dual faults "11" and "10" are alternately displayed at the IFC's seven-segment display.</p>
	<p><b>DESCRIPTION:</b> This fault is displayed at the furnace control after the first failed ignition attempt. It continues to be displayed until successful ignition or the furnace control has failed to ignite four consecutive times. After four attempts, the status of the fault is elevated to "10" and the furnace control (or I.F.C.) reacts as described under description for the fault code "10".</p>
	<p><b>EXPECTED OPERATION:</b> After the first failed ignition attempt, the fault ("11") is displayed and the inducer will complete a post-purge followed by a second ignition attempt. This cycle will be repeated until gas heat is established or until the fourth failed ignition attempt. After the fourth failed attempt, the furnace control (IFC) will proceed to one-hour lockout.</p>
	<p><b>CAUSE:</b> There can be several causes for a failed ignition attempt(s). The most common are:</p> <ul style="list-style-type: none"> <li>(1) The flame sense rod is unable to sense flame. It may need cleaning or may not be properly connected.</li> <li>(2) The gas valve may be turned off.</li> <li>(3) The igniter is not working properly. It may not be properly connected or the spark location may not be correct.</li> <li>(4) The furnace control may not be working properly and may need to be replaced.</li> <li>(5) Pilot circuit may be malfunctioning</li> </ul>
	<p><b>SOLUTION:</b> The solution will depend on the cause. Solutions to noted causes (1) through (5) above are:</p> <ul style="list-style-type: none"> <li>(1) Clean or replace the flame sense rod or check all connections and wire between the rod and the furnace control (or I.F.C.). Make sure furnace ground is properly connected.</li> <li>(2) Turn the valve on.</li> <li>(3) Replace or reposition the igniter or check all connections and wire between the igniter and the furnace control (or I.F.C.).</li> <li>(4) Replace the furnace control.</li> <li>(5) Check the solenoid valve and the pilot valve to determine if the pilot circuit is opening.</li> </ul>
<b>12</b>	<b>LOW FLAME SENSE</b>
	<p><b>STATUS:</b> The status of this fault is non-critical and furnace operation will continue as normal in heating (and all other) mode(s). If flame sense is low, the furnace control (or I.F.C.) may soon no longer be able to properly sense the flame and status of the problem may be elevated to the level of fault code "13" or fault "11" (if flame cannot be sensed at all).</p>
	<p><b>DESCRIPTION:</b> The flame sense current from the flame sense rod at the furnace control (or I.F.C.) is weak or marginal at best.</p>
	<p><b>EXPECTED OPERATION:</b> All operation (including gas heat) will proceed as normal with only the fault code ("12") displayed at the furnace control (I.F.C.).</p>
	<p><b>CAUSE:</b></p> <ul style="list-style-type: none"> <li>(1) The most common cause for low flame sense during heat operation is that the flame sense rod may need cleaning or may not be properly connected or wiring between the rod and the furnace control may be shorted or opened.</li> <li>(2) Another cause for low flame may be an improperly mounted or poorly grounded flame sensor.</li> </ul>
	<p><b>SOLUTION:</b></p> <ul style="list-style-type: none"> <li>(1) Clean or replace the flame sense rod or check all connections and wire between the rod and the furnace control (or I.F.C.).</li> <li>(2) Reinstall or replace flame sensor and check wiring and connections. Also make sure the furnace is properly grounded.</li> </ul>

**TABLE 9**  
**FAULT CODES WITH DESCRIPTIONS AND SOLUTIONS**

<b>FLAME LOST AFTER ESTABLISHED</b>	
<b>13</b>	<p><b>STATUS:</b> Flame loss is not a critical fault. Subsequent ignition attempts will follow and normal operation should resume. However, a lost flame can often be followed by failed ignition attempts then a one-hour lockout. Once the status has reached one-hour lockout, the fault condition is critical (although attempts at ignition will be made again after the 1 hour lockout).</p>
	<p><b>DESCRIPTION:</b> After a successful ignition trial, the flame (which was properly sensed) is no longer sensed. This can happen any time after successful ignition while a valid heat call is present.</p>
	<p><b>EXPECTED OPERATION:</b> When flame is lost, the fault code ("13") is immediately displayed at the IFC SSD's. The IBM (Indoor Blower Motor) is energized (if it was not already) at the correct speed (based on the demand from the thermostat) and completes blower off delay. The IDM (Induced Draft Motor) remains energized at the most recent speed (based on the demand from the thermostat or as required for ignition cycle) for post-purge. After both the post-purge and blower off delay are complete, the fault code ("13") is removed and a new attempt at ignition is made after a 2 minute cool down period. Often, the new ignition attempt will fail and operation will proceed as though a failed ignition has occurred from that point and will lock out (see fault code "10 &amp; 11").</p>
	<p><b>CAUSE:</b></p> <p>(1) The most common cause for low flame sense during heat operation is that the flame sense rod may need cleaning or may not be properly connected or wiring between the rod and the furnace control may be shorted or opened.</p> <p>(2) Another cause for low flame may be an improperly mounted or poorly grounded flame sensor.</p> <p>(3) Flame pattern may be unstable.</p>
	<p><b>SOLUTION:</b></p> <p>(1) Clean or replace the igniter/flame sense assembly (or check all connections and wire between the rod and the furnace control (or I.F.C.).</p> <p>(2) Reinstall or replace igniter/flame sense assembly and check wiring and connections. Also make sure the furnace is properly grounded.</p> <p>(3) Check that all burner assembly components are properly installed. Check for good seals between the igniter/flame sensor assembly and the combustion chamber.</p>
<b>UNEXPECTED FLAME</b>	
<b>14</b>	<p><b>STATUS:</b> This is an extremely critical fault and should rarely (if ever) be seen in the field. The furnace will not operate with this fault present.</p>
	<p><b>DESCRIPTION:</b> This fault indicates flame is present when it should not be. Flame is seen to be present when the gas valve and pilot valve is supposed to be off.</p>
	<p><b>EXPECTED OPERATION:</b> When unexpected flame is sensed, the IBM (Indoor Blower Motor) is energized at maximum heat speed and IDM (Induced Draft Motor) is energized at high speed. Both will remain energized until the fault is cleared. Response to any thermostat call is not permitted until the fault is cleared. Note that the gas valve circuit should not have been energized when the unexpected flame was sensed. When the condition causing the fault is cleared, the IDM will complete post-purge and the IBM will complete blower off-delay. The control will then enter a one-hour lockout and display the fault codes "10" (one-hour lockout) and "14" (unexpected flame) alternately for the duration of the one-hour lockout. Operation is returned to normal after the lockout period.</p>
	<p><b>CAUSE:</b></p> <p>(1) Field mis-wiring of 24VAC to the gas valve main solenoid.</p> <p>(2) Faulty gas valve and/or pilot valve may be stuck in the "OPEN" position.</p> <p>(3) Faulty furnace control (signal improperly sensed when it should not be sensed at all).</p>
	<p><b>SOLUTION:</b></p> <p>(1) Wire properly.</p> <p>(2) Replace gas valve or pilot solenoid as necessary.</p> <p>(3) Replace furnace control.</p>

**TABLE 9**  
**FAULT CODES WITH DESCRIPTIONS AND SOLUTIONS**

<b>MAIN LIMIT OPEN/AUXILIARY LIMIT OPEN</b>	
<b>22</b>	<p><b>STATUS:</b> This is a critical fault. The furnace will not operate in gas heat modes but all other modes (e.g. cooling) should function.</p>
	<p><b>DESCRIPTION:</b> The main limit auxiliary limit has opened or is sensed to be opened. This normally means that the temperature inside the heat exchanger area or blower area has gone above a certain predetermined critical value and heating operation is not permitted until the limit cools to within normal parameters.</p>
	<p><b>EXPECTED OPERATION:</b> When either of these limits open, the IBM (Indoor Blower Motor) will be energized at maximum heat speed. The gas valve circuit is de-energized (if it was energized) until the fault is cleared and the IDM (Induced Draft Motor) is energized at high speed and remains energized until the fault has cleared (limit has closed back). Response to thermostat cooling and fan calls will take place as normal. When the fault is cleared, the IBM will remain energized for the blower off-delay period.</p> <p>If the limit control was opened for less than 150 seconds (2m:30sec), operation will proceed as normal after the post-purge, blower off delay, and the 2 minute cool down period. However, if the limit is opened for more than 150 seconds, the control will declare a dead (non-functional) blower and proceed to a one-hour lockout and will alternately display fault codes "<b>10</b>" (one-hour lockout) and "<b>61</b>" (dead blower) at the furnace seven-segment display. Operation will proceed as described under fault code "<b>61</b>".</p>
	<p><b>CAUSE:</b></p> <ol style="list-style-type: none"> <li>(1) No airflow</li> <li>(2) Insufficient airflow</li> <li>(3) Faulty limit control</li> <li>(4) Loose or faulty wiring.</li> <li>(5) Dead (non-functional) blower.</li> <li>(6) Input too high</li> </ol> <p><b>SOLUTION:</b></p> <ol style="list-style-type: none"> <li>(1) Check for proper blower operation. Is the blower turning during heat (or any other) mode? If not, a blower motor fault should also be present. Check the wiring to the motor then check the motor. It may need replacing.</li> <li>(2) Check ductwork and filters. Determine the static pressure and make sure it is not above the published values for the furnace. Check the rate and outlet air temperature and verify they are correct. Also, perform the calibration cycle again (if the SA sensor is installed) by cycling power to the furnace.</li> <li>(3) Replace the limit control.</li> <li>(4) Check wiring and connections. Replace and/or repair as necessary.</li> <li>(5) See Fault Code 61 for description, causes, operation and solutions.</li> <li>(6) Insure properly sized burner orifices are installed. Check the manifold pressure and compare to the nameplate values. Adjust as needed.</li> </ol>
<b>LINE AND NEUTRAL REVERSED OR POOR GROUND</b>	
<b>26</b>	<p><b>STATUS:</b> This is a critical fault. The furnace will not operate in gas heat or any other modes.</p>
	<p><b>DESCRIPTION:</b> This fault code is an indication that line voltage and neutral are reversed to the furnace control or may also be an indication of a grounding issue. No operation is allowed to proceed until the problem is corrected.</p>
	<p><b>EXPECTED OPERATION:</b> No heating or cooling operation will take place.</p>
	<p><b>CAUSE:</b></p> <ol style="list-style-type: none"> <li>(1) Line and neutral to the furnace have been interchanged at the furnace.</li> <li>(2) Line voltage and neutral have been interchanged at the disconnect or at the breaker box.</li> <li>(3) Furnace control cannot properly sense ground.</li> </ol> <p><b>SOLUTION:</b></p> <ol style="list-style-type: none"> <li>(1) Check voltage with meter and reverse line and neutral if necessary in the junction box of the furnace.</li> <li>(2) Check voltage with meter and reverse line and neutral if necessary at the breaker box.</li> <li>(3) Check ground wire inside furnace cabinet is attached to sheet metal, verify ground to furnace cabinet and at breaker box.</li> </ol>
<b>MANUAL RESET OVER-TEMPERATURE SWITCH OPEN</b>	
	<p><b>STATUS:</b> This is a critical fault. The furnace will not operate in gas heat modes but all other modes (e.g. cooling) should function.</p>
	<p><b>DESCRIPTION:</b> The Manually Reset Limit Control (M.R.L.C.) is also known by the name over temperature switch. There can be several on any given furnace. When one or more of these limits open, they must be manually pushed back to the closed position (hence the name; <i>Manually</i> Reset) to force the acknowledgement of a critical fault. This fault occurs when the burner box has exceeded normal operating temperature.</p>
	<p><b>EXPECTED OPERATION:</b> When the MRLC (Manually Reset Limit Control) circuit has been opened, the IBM (Indoor Blower Motor) is energized at heating speed. The gas valve circuit is de-energized (if it was energized) and the IDM (Induced Draft</p>

**TABLE 9**  
**FAULT CODES WITH DESCRIPTIONS AND SOLUTIONS**

33	<p>Motor) is energized at high speed. Response to thermostat cooling calls will take place as normal with IBM energizing at the higher of the two blower speeds (heat or cool) when a call for cooling is also present. When the fault is cleared, the IDM will remain energized for post-purge and the IBM will remain energized for the user-selected blower off-delay period.</p> <p><b>CAUSE:</b></p> <ul style="list-style-type: none"> <li>(1) Blocked airflow through either the combustion air inlet or venturi inlet</li> <li>(2) Loose or faulty wiring.</li> <li>(3) Furnace has exceeded normal operating temperature</li> <li>(4) Broken or Cracked refractory</li> </ul> <p><b>SOLUTION:</b></p> <ul style="list-style-type: none"> <li>(1) Check for obstructions in combustion venting or venturi inlet. Clean filter if equipped.</li> <li>(2) Check wiring and connections. Replace and/or repair as necessary.</li> <li>(3) Check Rate and BTU/hour usage of furnace</li> <li>(4) Replace burner assembly.</li> </ul>
<b>INDUCED DRAFT MOTOR OVERCURRENT</b>	
34	<p><b>STATUS:</b> This is a critical fault. The furnace will not operate in gas heat modes, but all other modes (e.g. cooling) should function if present simultaneously with a heating call (e.g. defrost call in dual-fuel mode).</p> <p><b>DESCRIPTION:</b> This fault indicates that the inducer is not working properly. Note: This fault may be seen under normal operating conditions if power is lost and returned quickly (within 30 seconds) while operating in gas heating mode.</p> <p><b>EXPECTED OPERATION:</b> The fault is displayed when too much or too little current is detected on the inducer circuit.</p> <p><b>CAUSE:</b></p> <ul style="list-style-type: none"> <li>(1) Power outage</li> <li>(2) Bad wiring to inducer</li> <li>(3) Bad inducer</li> <li>(4) Bad (IFC)</li> </ul> <p><b>SOLUTION:</b></p> <ul style="list-style-type: none"> <li>(1) Reset power to unit and clear fault</li> <li>(2) Check wiring and connections between inducer and IFC. Correct or replace as necessary.</li> <li>(3) Replace inducer.</li> <li>(4) Replace IFC</li> </ul>
<b>FLAME LED NOT DETECTED</b>	
42	<p><b>STATUS:</b> This is a non critical fault. The furnace will operate in all operations even if this fault is displayed.</p> <p><b>DESCRIPTION:</b> This fault indicates that flame LED board in the burner compartment is not working.</p> <p><b>EXPECTED OPERATION:</b> This fault is displayed when there is no power being drawn from the circuit.</p> <p><b>CAUSE:</b></p> <ul style="list-style-type: none"> <li>(1) Flame LED board is unplugged.</li> <li>(2) Flame LED board has malfunctioned.</li> </ul> <p><b>SOLUTION:</b></p> <ul style="list-style-type: none"> <li>(1) Check wiring connections to the flame indicator board.</li> <li>(2) Replace the flame indicator board.</li> </ul>
<b>IGNITION PRESSURE SWITCH CLOSED WHEN SHOULD BE OPEN</b>	
43	<p><b>STATUS:</b> This is a critical fault. The furnace will not operate in gas heat modes but all other modes (e.g. cooling) should function.</p> <p><b>DESCRIPTION:</b> The ignition pressure switch should not be closed when the inducer is not running. If it is this is a sign of a serious condition. The switch may be welded closed or purposely bypassed in the field. Before any heat cycle can begin the pressure switch is tested to make sure that it is open. The switch is ignored except in gas heating modes.</p> <p><b>EXPECTED OPERATION:</b> There will be no other operation than displaying of the fault code and diagnostic messages to the homeowner and technician. The fault code is only present during a heat call before pre-purge or calibration begins.</p> <p><b>CAUSE:</b></p> <ul style="list-style-type: none"> <li>(1) Faulty switch</li> <li>(2) Pressure switch physically bypassed in the field</li> <li>(3) Loose or faulty wiring</li> <li>(4) Abnormally high negative pressure present on vent system without inducer running.</li> </ul> <p><b>SOLUTION:</b></p> <ul style="list-style-type: none"> <li>(1) Replace ignition pressure switch.</li> <li>(2) Remove bypass and restore correct operation. Determine reason for bypass and correct issue. Notify homeowner and proper authorities of illegal tampering if necessary.</li> <li>(3) Check wiring and connections. Replace and/or repair as necessary.</li> <li>(4) Check for proper venting and terminations as defined in the National Fuel Gas Code.(NFPA 54)</li> </ul>

**TABLE 9**  
**FAULT CODES WITH DESCRIPTIONS AND SOLUTIONS**

<b>55</b>	<b>COMBUSTION PRESSURE SWITCH CLOSED WHEN SHOULD BE OPEN</b>
	<b>STATUS:</b> This is a critical fault. The furnace will not operate in gas heat modes but all other modes (e.g. cooling) should function if present simultaneously with a heating call (e.g. defrost call in dual-fuel mode).
	<b>DESCRIPTION:</b> The combustion pressure switch should not be closed when the inducer is not running. If it is this is a sign of a serious condition. The switch may be welded closed or purposely bypassed in the field. Before any heat cycle can begin the pressure switch is tested to make sure that it is open. The switch is ignored except in gas heating modes.
	<b>EXPECTED OPERATION:</b> There will be no other operation than displaying of the fault code and diagnostic messages to the homeowner and technician. The fault code is only present during a heat call before pre-purge or calibration begins.
	<b>CAUSE:</b>
	<ul style="list-style-type: none"> <li>(1) Faulty switch.</li> <li>(2) Pressure switch physically bypassed in the field.</li> <li>(3) Loose or faulty wiring.</li> <li>(4) Abnormally high negative pressure present on vent system without inducer running.</li> </ul>
	<b>SOLUTION:</b>
	<ul style="list-style-type: none"> <li>(1) Replace combustion pressure switch.</li> <li>(2) Remove bypass and restore correct operation. Determine reason for bypass and correct issue. Notify homeowner and proper authorities of illegal tampering if necessary.</li> <li>(3) Check wiring and connections. Replace and/or repair as necessary.</li> <li>(4) Check for proper venting and terminations as defined in the National Fuel Gas Code.(NFPA 54)</li> </ul>
<b>56</b>	<b>IGNITION PRESSURE SWITCH OPEN WHEN SHOULD BE CLOSED</b>
	<b>STATUS:</b> This is a critical fault. The furnace will not operate in gas heat modes but all other modes (e.g. cooling) should function if present simultaneously with a heating call (e.g. defrost call in dual-fuel mode).
	<b>DESCRIPTION:</b> This fault indicates that the pressure switch is open when the inducer is energized. This fault can be displayed any time during the heat call and only after the pre-purge.
	<b>EXPECTED OPERATION:</b> <u>(1) DISPLAYED BEFORE HEAT IS ESTABLISHED:</u> The IBM (Indoor Blower Motor) will not be energized. The fault code will not be displayed until the IDM (Induced Draft Motor) has been energized for a minimum of ten seconds. The IDM will remain energized at the high speed (high speed is default pre-purge speed) for a period of five minutes after the beginning of the pre-purge attempt. After five minutes, the IDM is de-energized and second attempt at pre-purge is made (as long as the heat call is still present). This cycle is repeated indefinitely until either the pressure switch closes or the heat call is lost. <u>(2) DISPLAYED AFTER HEAT IS ESTABLISHED</u> -in steady-state heating mode, it will wait a minimum of 2 seconds before de-energizing the gas valve relay and shutting down the unit. It will perform a 2 minute cool down period before proceeding with pressure switch proving if the heat call is not satisfied.
	<b>CAUSE:</b>
	<ul style="list-style-type: none"> <li>(1) Blockage in the exhaust vent.</li> <li>(2) Faulty or disconnected inducer.</li> <li>(3) Faulty control board (inducer drive circuitry).</li> <li>(4) Loose or faulty wiring.</li> <li>(5) Disconnected, blocked, split or cut pressure switch hoses.</li> <li>(6) Faulty pressure switch.</li> </ul>
	<b>SOLUTION:</b>
	<ul style="list-style-type: none"> <li>(1) Check the vent system for blockage and proper termination and repair as necessary.</li> <li>(2) Repair or replace inducer and/or inducer wiring and/or electrical connections.</li> <li>(3) Replace control board.</li> <li>(4) Check wiring and connections. Replace and/or repair as necessary.</li> <li>(5) Replace hoses as necessary.</li> <li>(6) Replace the pressure switch.</li> </ul>

**TABLE 9**  
**FAULT CODES WITH DESCRIPTIONS AND SOLUTIONS**

<b>COMBUSTION PRESSURE SWITCH OPEN WHEN SHOULD BE CLOSED</b>	
<b>57</b>	<b>STATUS:</b> This is a critical fault. The furnace will not operate in gas heat modes but all other modes (e.g. cooling) should function if present simultaneously with a heating call (e.g. defrost call in dual-fuel mode).
	<b>DESCRIPTION:</b> This fault indicates that the pressure switch is open when the inducer is energized. This fault can be displayed any time during the heat call and only after the pre-purge or 2 minute cool down period.
	<b>EXPECTED OPERATION:</b> (1) <b>DISPLAYED BEFORE HEAT IS ESTABLISHED:</b> The IBM (Indoor Blower Motor) will not be energized. The fault code will not be displayed until the IDM (Induced Draft Motor) has been energized for a minimum of ten seconds. The IDM will remain energized at the high speed (high speed is default pre-purge speed) for a period of five minutes after the beginning of the pre-purge attempt. After five minutes, the IDM is de-energized and second attempt at pre-purge is made (as long as the heat call is still present). This cycle is repeated indefinitely until either the pressure switch closes or the heat call is lost. (2) <b>DISPLAYED AFTER HEAT IS ESTABLISHED</b> -in steady-state heating mode, it will wait a minimum of 2 seconds before de-energizing the gas valve relay and shutting down the unit. It will perform a 2 minute cool down period before proceeding with pressure switch proving if the heat call is not satisfied.
	<b>CAUSE:</b> (1) Blockage in the exhaust vent. (2) Faulty or disconnected inducer. (3) Faulty control board (inducer drive circuitry). (4) Loose or faulty wiring. (5) Disconnected, blocked, split or cut pressure switch hoses. (6) Faulty pressure switch.
	<b>SOLUTION:</b> (1) Check the vent system for blockage and proper termination and repair as necessary. (2) Repair or replace inducer and/or inducer wiring and/or electrical connections. (3) Replace control board. (4) Check wiring and connections. Replace and/or repair as necessary. (5) Replace hoses as necessary. (6) Replace the pressure switch.
<b>WATER SENSOR JUMPER NOT ATTACHED</b>	
<b>58</b>	<b>STATUS:</b> This is a critical fault experienced by the furnace. The furnace will not operate in gas heat modes but all other modes (e.g. cooling) should function if a call is present.
	<b>DESCRIPTION:</b> The IFC cannot detect electrical continuity between pins 2 and 3 of connector P3 of the furnace control. The IFC looks for continuity between these pins to determine if the water sensors (2) are present in the circuit. When both sensors are present and properly connected and wiring is not damaged, there should be electrical continuity between these pins. 80+ Furnaces do not have these water sensors and will be jumped between pins 2 and 3 of Plug 3 (PL3).
	<b>EXPECTED OPERATION:</b> No gas heating operation can proceed and the fault is displayed. All other modes (e.g. cooling) of operation should operate as normal.
	<b>CAUSE:</b> (1) Connection of P4 at the IFC is not properly made.
	<b>SOLUTION:</b> (1) Repair or replace wiring. Replace IFC

**TABLE 9**  
**FAULT CODES WITH DESCRIPTIONS AND SOLUTIONS**

<b>61</b>	<b>BLOWER FAULT - DEAD BLOWER</b>
	<b>STATUS:</b> This is a critical fault. The furnace will not operate in any mode.
	<b>DESCRIPTION:</b> The blower has failed critically or there is a critical motor fault - such as thermal limit trip that prevents the blower motor from running.
	<b>EXPECTED OPERATION:</b> If the furnace was in heating operation when this fault occurred, blower operation will immediately stop and the furnace will shut down normally with post-purge at the correct speed. After the post purge (or immediately if no heat call was present), no other operation (including thermostat calls) will occur until this fault is cleared. This fault may be displayed in heating mode after the main limit control has been opened for more than 150 seconds (2m:30sec) each time. If this happens 4 times consecutively the IFC determines that the motor and/or blower is not functional and enters a hard lockout condition requiring repair of the blower/motor and manual reset of power to the furnace.
	<b>CAUSE:</b> (1) The motor has tripped on thermal limit because of a restriction or bearing failure. (2) Wiring to the motor has become compromised. (3) The blower wheel has become damaged or is not properly attached to the motor shaft. (4) The motor has failed catastrophically.
<b>SOLUTION:</b> (1) Remove obstruction or replace motor. (2) Inspect and replace or repair wiring or connectors to the motor as necessary. (3) Replace the blower wheel and/or attach the blower wheel to the motor shaft properly. (4) Replace the motor.	
<b>71</b>	<b>INDUCER CIRCUITRY FAULT</b>
	<b>STATUS:</b> This is a critical fault. The furnace will not operate in gas heat modes, but all other modes (e.g. cooling) should function if present simultaneously with a heating call (e.g. defrost call in dual-fuel mode).
	<b>DESCRIPTION:</b> This fault indicates that there is no communications with the motor processor.
	<b>EXPECTED OPERATION:</b> The fault is displayed when too much or too little current is detected on the inducer circuit.
	<b>CAUSE:</b> (1) Failed inducer communication circuitry on IFC. (2) Internal Control Fault
<b>SOLUTION:</b> (1) Cycle power and, if problem persists, replace the IFC. (2) Cycle power and, if problem persists, replace the IFC.	
<b>74</b>	<b>GAS INLET PRESSURE SWITCH OPEN</b>
	<b>STATUS:</b> This is a critical fault. The furnace will not operate in gas heat modes but all other modes (e.g. cooling) should function if present simultaneously with a heating call (e.g. defrost call in dual-fuel mode).
	<b>DESCRIPTION:</b> The inlet gas pressure has dropped below a point where the furnace normally operates during a call for heat.
	<b>EXPECTED OPERATION:</b> Gas inlet pressure switch is to ensure proper gas supply pressure to the furnace. If the Gas Pressure switch is open when a call for heat is present, the control will de-energize the gas valve, de-energize induced draft motor (after post purge), energize indoor blower on heat speed, and set fault code "74". When the Gas Pressure switch re-closes or call for heat is lost, the control runs the indoor blower through the selected fan off delay. The control will start/re-start the heat cycle after the blower off delay and 2 minute cool down period are completed if the call for heat is still present.
	<b>CAUSE:</b> (1) The gas line valve to the furnace is not on. (2) Undersized gas line. (3) Gas line pressure is too low.
<b>SOLUTION:</b> (1) Check the gas line valve and verify gas is flowing to the unit. (2) Gas line is too small. (3) Regulator needs adjusted or too many gas appliances running at one time.	

**TABLE 9**  
**FAULT CODES WITH DESCRIPTIONS AND SOLUTIONS**

<b>VENTURI AIR INLET PRESSURE SWITCH OPEN</b>	
<b>75</b>	<b>STATUS:</b> This is a critical fault. The furnace will not operate in gas heat modes but all other modes (e.g. cooling) should function if present simultaneously with a heating call (e.g. defrost call in dual-fuel mode).
	<b>DESCRIPTION:</b> There is an obstruction at or near the inlet of the fuel and air mixing venturi.
	<b>EXPECTED OPERATION:</b> If the venturi air inlet pressure switch is open when a call for heat is present and the MRLC over temperature switch, gas pressure switch, and the main limit are closed. The control will de-energize the gas valve, de-energize induced draft motor after post purge, energize indoor blower on heat speed and set the fault to "75". When the switch re-closes or call for heat is lost, the control runs the indoor blower through the selected fan off delay. If the heat call remains, the control will complete the blower off delay and blower cool down before re-starting the heat cycle.
	<b>CAUSE:</b> (1) Dirty venturi inlet filter (2) Obstructed venturi inlet (3) Faulty Switch
	<b>SOLUTION:</b> (1) Clean filter (2) Remove obstruction (3) Replace switch
<b>INTERNAL CONTROL FAULT DETECTED</b>	
<b>93</b>	<b>STATUS:</b> This is a critical fault. The furnace will not operate in any mode of operation.
	<b>DESCRIPTION:</b> This is a severe fault that should rarely (if ever) be discovered in the field. It is an indicator of a circuitry fault or internal microprocessor fault on the furnace control (or I.F.C.) or voltage applied to the main gas valve solenoid when there should be none.
	<b>EXPECTED OPERATION:</b> The furnace was in heating operation when this fault occurred, the gas valve will immediately close (flame will be lost), IBM (Indoor Blower Motor) operation will immediately stop and the furnace will shut down normally (except without IBM operation) with IDM (Induced Draft Motor) post-purge at the correct speed. After the post purge no other operation will occur until this fault is cleared. However, this fault may also indicate an internal microprocessor failure. This may mean that the heat call will not end as expected and that all outputs will be de-energized and gas valve closed immediately when the fault is sensed.
	<b>CAUSE:</b> (1) 24VAC or similar voltage applied to the main gas valve solenoid circuit unexpectedly. (2) Furnace control software test failure - failed furnace control (or I.F.C.).
	<b>SOLUTION:</b> (1) Check for mis-wiring in the furnace. (2) Replace the furnace control (or I.F.C.).

# FIELD SELECTIONS & ADJUSTMENTS

## FIELD SELECTIONS — DIPSWITCHES

A dipswitch bank; SW1 is provided for some field adjustments. Heating blower off delay, cooling (and heat-pump) blower off delay, display (7-Segment) orientation and fault clear are the adjustments and functions that can be handled using the dipswitches.

### Seven-Segment Display Orientation; SW1

As the control will be applied in a multi-position future furnace design a means of changing the orientation of the seven segment display is required. This dipswitch is to be labeled SW1. Factory setting of the SW1 dipswitch is OFF. The factory setting display orientation is with the control placed in a vertical orientation and the low voltage terminal block T2 is in the bottom position.

**NOTE:** This furnace is currently approved for upflow only. Leave switch in "OFF" position.

### Heat Blower-Off Delay; SW2 & SW3

A means of controlling the HEAT speed blower "off" delay time is provided. The dipswitches are labeled SW2 and SW3. The following table defines the settings:

SW2	SW3	
OFF	OFF	90 seconds
ON	OFF	120 seconds
OFF	ON	160 seconds
ON	ON	180 seconds (Factory Setting)

**FIGURE 27**  
DIPSWITCH MAP

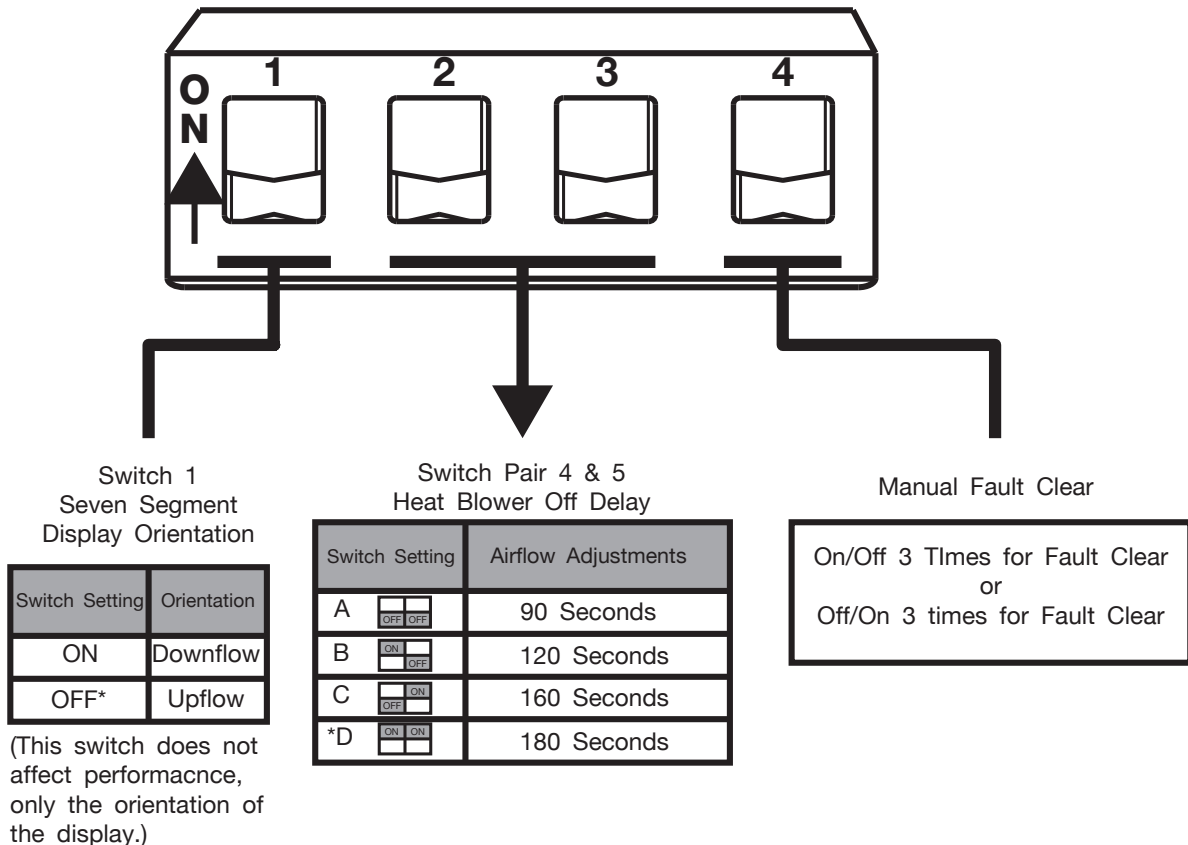

\* Factory default position

# FIELD SELECTIONS & ADJUSTMENTS

## FAULT CLEAR

### MANUAL FAULT CLEAR; SW4

Faults will automatically be cleared from the fault buffer after one week. The fault buffer can also be manually cleared if this is desired. For the first 30 seconds after a change in state of dipswitch SW4, the furnace control will wait to determine if the

switch becomes *on/off/on/off/on/off* or *off/on/off/on/off/on*

### FAULT RECALL

Upon power reset, the three most recent faults which are less than one week old will be flashed in succession from the most recent to the oldest. This will be done as a diagnostic aid to the

within 30 seconds. When this action is detected within 30 seconds, the fault code memory buffer shall be cleared. Be sure to return the dipswitch to the original state (on or off) or is in the desired position after clearing the fault buffer using this method.

field technician. After one week, a fault will be removed from the fault buffer.

## FLAME STATUS L.E.D. (AMBER)

A yellow or amber L.E.D. is provided to indicate flame status. When normal flame is sensed, the flame L.E.D. is continuously on. The flame L.E.D. will flash at a rate of one to four flashes per second if a weak flame is detected. If an unexpected flame is detected, the L.E.D. will flash rapidly. The L.E.D. is off when

there is no flame detected.

For more diagnostics information, consult the wiring diagram and diagnostics chart at the end of this book.

## ADJUSTING OR CHECKING FURNACE INPUT

The maximum gas supply pressure to the furnace should be 10.5" w.c. for natural gas. The minimum gas supply pressure for purposes of input adjustment to the furnace should be 6" w.c. for natural gas.

A calibrated manometer is required for accurate gas pressure readings.

The manifold pressure should be set at 3.5" w.c. for natural gas. Only small variations in the gas flow should be made by means of the pressure regulator adjustment. In no case should the final manifold pressure vary more than plus or minus 0.3" w.c. from the above- specified pressures. To adjust the pressure regulator, remove the regulator cap and turn the adjustment screw clockwise to increase pressure or counterclockwise to decrease pressure. Then replace the regulator cap securely. Any necessary major changes in the gas flow rate should be made by changing the size of the burner orifice. See the Orifice Selection Chart on the following page for available orifice sizes and the approximate heating value ranges they will cover.

Before changing the orifice, shut off the manual gas valve and disconnect power to the furnace.

**CHECKING FURNACE INPUT IS CRITICAL TO PREVENT UNDER FIRING OR OVER FIRING BEYOND ITS DESIGN-RATED INPUT. ADDITIONALLY, THERMAL ACOUSTICS IS AN INDICATOR OF INCORRECT OR LOW BTU INPUT.**

Use the following formula to determine input rate.

$$\text{RATE} = \frac{3600 \times \text{Heating Value of Gas in BTU/hr}}{\text{Time in seconds to use 1 ft}^3 \text{ of gas}}$$

Start the furnace and measure the time required to burn one cubic foot of gas. Prior to checking the furnace input, make certain that all other gas appliances are shut off, with the exception of pilot burners. Time the meter with only the furnace in operation. See Table 9.

# FIELD SELECTIONS & ADJUSTMENTS

**TABLE 10**  
METER TIME

METER TIME IN MINUTES AND SECONDS FOR NORMAL INPUT RATINGS OF FURNACES EQUIPPED FOR NATURAL GAS							
INPUT (BTU/HR)	METER SIZE (FT <sup>3</sup> /REV)	HEATING VALUE OF GAS (BTU/FT <sup>3</sup> )					
		990		1030		1070	
		MIN	SEC	MIN	SEC	MIN	SEC
50,000	ONE	1	12	1	15	1	18
	TEN	12	00	12	30	13	00
70,000	ONE	0	52	0	54	0	56
	TEN	8	40	9	0	9	20
98,000	ONE	0	37	0	38	0	40
	TEN	6	10	6	20	6	40

Formula: Input BTU/HR =  $\frac{\text{Heating Value of Gas (BTU/ft}^3) \times 3600 \times \text{correction factor}}{\text{Time (in seconds) for 1 cubic ft of Gas}}$

## SETTING INPUT RATE

The furnace is shipped from the factory with a specific sized orifice noted in the chart below. It is sized for natural gas having a heating value of 1030 BTU/cu. ft. and a specific gravity of .60.

See the Orifice Selection Chart below for available orifices and the approximate heating value ranges they will cover.

Since heating values vary geographically, the manifold pressure may need to be changed to adjust the furnace to its nameplate input. Consult the local gas utility to obtain the yearly average heating value. Manifold pressure should be between 3.2" and 3.8" water column.

Orifice Selection Chart				
Furnace Model Input	Orifice Size	Heating Valve Range (Approximate) in BTU/CUBIC FT	Part Number	Color
50K	#53	940-1020	62-106977-07	SILVER
	1.45 mm*	990-1070	62-106977-06	BLUE
	1.40 mm	1040-1120	62-106977-01	SILVER
70K	1.85 mm	940-1020	62-106977-02	BRASS
	1.80 mm*	990-1070	62-106977-05	GREEN
	1.75 mm	1040-1120	62-106977-04	BRASS
100K	2.20 mm	940-1020	62-106977-10	BLACK
	2.15 mm*	990-1070	62-106977-09	RED
	2.10 mm	1040-1120	62-106977-08	BLACK

\*-FACTORY ORIFICE SIZE

NOTE: HEATING VALUES LISTED ARE DRY

# HIGH ALTITUDE INSTALLATION

This Ultra Low NOx furnace maintains efficiency by operating under a specific air fuel mixture. Maintaining the proper fuel mixture is essential to proper operation of the furnace. This unit does not require any component changes from 0 - 5,500 ft. above sea level. At elevations higher than 2,000 ft. these units require a 2% de-rate for every 1,000 ft. of elevation above sea level. Over 2,000 ft. of elevation, the manifold pressure can be adjusted between 3.00" - 4.50" W.C. to maintain the proper input capacity in BTUs per hour (referred to as rate) for the altitude of the installation.

Adjust the input rate by adjusting manifold pressure to match the rate and elevation in the chart below. To calculate rate see the section ADJUSTING OR CHECKING FURNACE INPUT.

To facilitate ignition at altitudes above 2,000 ft., adjust manifold pressure to approximately 4.0". Turn the manifold adjustment screw approximately 2 turns clockwise before attempting to start the unit for the first time (this will be approximately 4.0" WC on the manifold) Once lit, monitor manifold pressure while adjusting gas valve to achieve the desired rate per the relevant elevation of the installation (see chart).

De-rate input BTU/h 2% per 1,000K ft above sea level this unit is qualified up to 5,500ft				
De-rated input = nameplate input x ((1-(elevation ft/1,000ft) X.02)				
% de-rated	Elevation FT.	98,000 BTU/h	70,000 BTU/h	50,000 BTU/h
No de-rate required	2,000 and below	98,000	70,000	50,000
4-5%	2001 to 2,500	93,100	66,500	47,500
5-6%	2501 to 3,000	92,120	65,800	47,000
6-7%	3001 to 3,500	91,140	65,100	46,500
7-8%	3501 to 4,000	90,160	64,400	46,000
8-9%	4001 to 4,500	89,180	63,700	45,500
9-10%	4501 to 5,000	88,200	63,000	45,000
10-11%	5001 to 5,500	87,220	62,300	44,500

# AIRFLOW

The importance of proper air flow over the heat exchanger cannot be over emphasized.

## CAUTION

IT IS IMPORTANT THAT EACH DUCT SYSTEM BE SIZED AND INSTALLED FOR THE SPECIFIC APPLICATION BY PROPERLY APPLYING THE APPROPRIATE INDUSTRY ACCEPTED STANDARD. IF LESS THAN MINIMUM STANDARDS ARE APPLIED, THE EQUIPMENT USER COULD EXPECT TO EXPERIENCE HIGHER UTILITY BILLS, MAJOR COMPONENT FAILURE, VARYING DEGREES OF AIR NOISE OR OTHER UNSATISFACTORY ISSUES, OVER WHICH THE MANUFACTURER HAS NO CONTROL.

One of the most common causes of heat exchanger failure is overheating due to low air flow. An air flow table is located inside the blower door and on the following pages.

### TEMPERATURE RISE CHECK

To determine if the air flow is correct, make a temperature rise check.

1. Insert a thermometer in the supply air duct as close to the furnace as possible yet out of a direct line from the heat exchanger. See Figure 29.
2. Insert a thermometer in the return air duct as close to the furnace as possible.
3. Operate the furnace.
4. When the thermometer in the supply air duct stops rising (approximately five minutes), subtract the return air temperature from the supply air temperature. The difference is the temperature rise.
5. Compare the measured temperature rise to the approved temperature rise range listed on the furnace name plate. See Figure 26.

If the measured temperature rise is above the approved range, either the air flow is too low or the manifold pressure needs to be adjusted. More air must be moved by speeding up the blower, by removing restrictions in the duct system, or by adding more supply or return air duct. If the measured temperature rise is below the approved range, either the air flow is too much or the manifold pressure needs to be adjusted. Use lower speed tap on the multi-speed blower.

**IMPORTANT:** The measured temperature rise should be in the middle of the range.

**IMPORTANT:** Some high-efficiency filters have a greater than normal resistance to airflow. This can adversely affect furnace operation. BE SURE TO CHECK AIRFLOW if using any filter other than factory-provided filter.

## WARNING

THE MEASURED TEMPERATURE RISE SHOULD BE AS CLOSE TO THE MIDDLE OF THE STATED RANGE AS POSSIBLE. FOR EXAMPLE, IF THE RISE RANGE IS 40 TO 70°F (4.5°-21°C), THE MIDDLE OF THE RISE RANGE IS 55°F (12.8°C). IN ALL APPLICATIONS, THE INSTALLER MUST ADJUST THE TEMPERATURE RISE TO THIS "MIDDLE" POINT AS CLOSELY AS POSSIBLE. ALSO, THE TEMPERATURE RISE SHOULD NEVER BE ABOVE OR FALL BELOW THE STATED RANGE. DOING SO COULD CAUSE DAMAGE TO THE HEAT EXCHANGER OR INTERMITTENT OPERATION. THIS COULD CAUSE INJURY OR DEATH AND WILL VOID THE MANUFACTURER'S WARRANTY FOR THIS PRODUCT.

FIGURE 28  
TEMPERATURE RISE MEASUREMENT

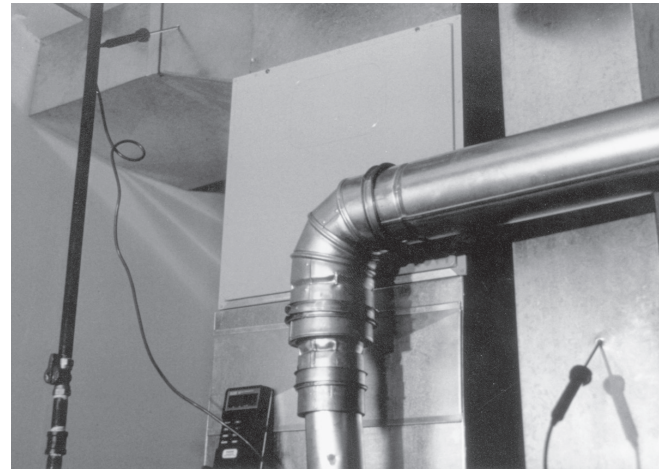

# SAFETY FEATURES

## LIMIT CONTROL

The high limit cut-off temperature is set at the factory and cannot be adjusted. The temperature setting prevents the air temperature leaving the furnace from exceeding the maximum outlet air temperature, which, if exceeded, will shut the furnace down.

There are several reasons for a limit switch to open and almost always involve low airflow through the furnace.

1. A dirty or restricted air filter.
2. A dirty or restricted cooling coil.
3. Undersized or restricted return air system.
4. Undersized or restricted supply air system.
5. A problem affecting the main blower:
  - A. A wrong speed tap selection.
  - B. Failing motor bearings.
  - C. Low voltage to the motor.
  - D. Dirty blower wheel.
  - E. Wrong motor rotation.
  - F. Blower wheel slipping on the motor shaft.
6. Overfiring the furnace with too much gas pressure.
7. Ventilation problems.
8. Failed blower motor.

## OVER TEMPERATURE SAFETY SWITCHES

Furnaces are equipped with safety switches to protect against over temperature conditions in the burner compartment, which, if tripped, will terminate the heating cycle. In the event of an over temperature condition, the switch will shut the furnace down. This switch for the furnace is located on the top, left side and right side of the burner box. If a switch is tripped, it must be manually reset. DO NOT jumper or reset this switch. If this switch should trip, a qualified installer, service agency or the gas supplier should be called to diagnose and/or correct the source of tripping. Caution must be used as some components may be hot.

## BURNER ASSEMBLY

NOTICE: This furnace is equipped with a pre-mix burner assembly. This burner assembly is non-serviceable and should be replaced as an entire assembly only. Burner assemblies are available from authorized parts dealer.

## PRESSURE SWITCHES

This furnace is equipped with (2) normally-open pressure switches that monitor pressure conditions within the furnace vent system during the heating cycle.

There are several reasons for the pressure switch not to close.

1. An inoperative induced draft blower.
2. A loose or leaky pressure switch hose.
3. A blockage in the exhaust vent.
4. Severe downdrafts canceling the draft from the inducer fan.
5. A leaky gasket at the induced draft blower.
6. Improperly sized or installed vent.

The pressure switch contacts must open before the unit can go through another heating cycle.

This furnace is also equipped with (1) normally-closed pressure switch that monitors the conditions of the inlet to the venturi/gas entry into the system. If this inlet becomes obstructed or restricted by a clogged filter (if equipped) the switch will open and shut down the system.

### WARNING

**DO NOT BYPASS, JUMPER, OR REMOVE ANY SAFETY SWITCH FROM THE FURNACE CONTROL CIRCUIT. IF A SAFETY SWITCH CAUSES THE FURNACE TO SHUT DOWN OR OPERATE INTERMITTENTLY, IT IS AN INDICATION OF A POTENTIAL SAFETY HAZARD THAT MUST BE ADDRESSED BY A QUALIFIED TECHNICIAN, SERVICE AGENCY OR THE GAS SUPPLIER. DO NOT RESET SAFETY CONTROLS WITHOUT CORRECTIVE ACTION AND/OR VERIFICATION OF PROPER SAFE OPERATION BY A QUALIFIED INSTALLER, SERVICE AGENCY OR THE GAS SUPPLIER.**

**REPLACE ANY SAFETY CONTROL COMPONENT ONLY WITH IDENTICAL OEM REPLACEMENT PARTS. WHEN A NEW SAFETY SWITCH IS INSTALLED, IT MUST BE TESTED FOR A MINIMUM OF 15 MINUTES WITH THE FURNACE OPERATING AT MAXIMUM INPUT RATE AND WITH BOTH BLOWER AND BURNER DOOR INSTALLED. IF THE FURNACE IS INSTALLED IN A CLOSET, THE CLOSET DOOR MUST ALSO BE CLOSED FOR THIS TEST. REPEAT THE TEST AT THE MINIMUM INPUT RATE IF THE FURNACE IS A MULTI-STAGE FURNACE.**

# MAINTENANCE

## MAINTENANCE

### ▲ WARNING

THESE INSTRUCTIONS ARE INTENDED AS AN AID TO QUALIFIED SERVICE PERSONNEL FOR PROPER INSTALLATION, ADJUSTMENT AND OPERATION OF THIS UNIT. READ THESE INSTRUCTIONS THOROUGHLY BEFORE ATTEMPTING INSTALLATION OR OPERATION. FAILURE TO FOLLOW THESE INSTRUCTIONS MAY RESULT IN IMPROPER INSTALLATION, ADJUSTMENT, SERVICE OR MAINTENANCE, POSSI-

BLY RESULTING IN FIRE, ELECTRICAL SHOCK, CARBON MONOXIDE POISONING, EXPLOSION, PROPERTY DAMAGE, PERSONAL INJURY OR DEATH.

DISCONNECT MAIN ELECTRICAL POWER TO THE UNIT BEFORE ATTEMPTING ANY MAINTENANCE. FAILURE TO DO SO CAN CAUSE ELECTRICAL SHOCK RESULTING IN PERSONAL INJURY OR DEATH.

## FILTERS

### ▲ CAUTION

DO NOT OPERATE THE SYSTEM FOR EXTENDED PERIODS WITHOUT FILTERS. A PORTION OF THE DUST ENTRAINED IN THE AIR MAY TEMPORARILY LODGE IN THE AIR DUCT RUNS AND AT THE SUPPLY REGISTERS. ANY RECIRCULATED DUST

PARTICLES WILL BE HEATED AND CHARRED BY CONTACT WITH THE FURNACE HEAT EXCHANGER. THIS RESIDUE WILL SOIL CEILINGS, WALLS, DRAPES, CARPETS AND OTHER HOUSEHOLD ARTICLES.

## VENTURI AIR INLET FILTER

This furnace may be equipped with a Venturi air inlet filter to prevent dust/contaminants from entering the burner assembly. This filter must be cleaned periodically for the furnace to operate properly.

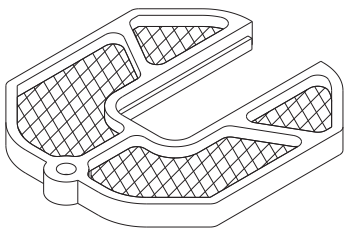

VENTURI AIR INLET FILTER: LOCATED ON TOP OF VENTURI HOUSING IN BURNER COMPARTMENT.

ST-A-1252-33\_S2-00

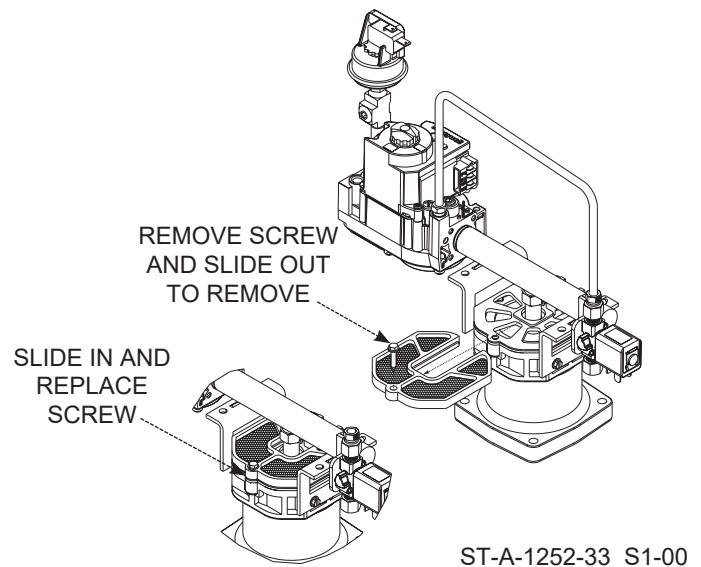

## LUBRICATION

**IMPORTANT: DO NOT** attempt to lubricate the bearings on the blower motor or the induced draft blower motor. Addition of lubricants can reduce the motor life and void the warranty.

The blower motor and induced draft blower motor are permanently lubricated by the manufacturer and do not require further attention.

It is recommended that the blower motor and induced draft blower motor be cleaned periodically by a qualified installer, service agency, or the gas supplier to prevent the possibility of overheating due to an accumulation of dust and dirt on the windings or on the motor exterior. And, as suggested elsewhere in these instructions, the air filters should be kept clean. Dirty filters can restrict airflow. The motor depends upon sufficient air flowing across and through it to keep from overheating.

## SYSTEM OPERATION INFORMATION

### ADVISE THE CUSTOMER

1. Keep the air filters clean. The heating system will operate better, more efficiently and more economically.
2. Arrange the furniture and drapes so that the supply air registers and the return air grilles are unobstructed.
3. Close doors and windows. This will reduce the heating load on the system.
4. Avoid excessive use of kitchen exhaust fans.
5. Do not permit the heat generated by television, lamps or radios to influence the thermostat operation.
6. Except for the mounting platform, keep all combustible articles 3 feet from the furnace and vent system.
7. **IMPORTANT:** Replace all blower doors and compartment covers after servicing the furnace. Do not operate the unit without all panels and doors securely in place.
8. Explain the advantages of continuous fan operation to the customer.

### ANNUAL INSPECTION

- The furnace should operate for many years without excessive scale build-up in the flue passageways. However, it is recommended that a qualified installer, service agency, or the gas supplier annually inspect the flue passageways, the vent system and the main burners for continued safe operation. Pay particular attention to deterioration from corrosion or other sources.
- **IMPORTANT:** It is recommended that at the beginning and at approximately half way through the heating season, a visual inspection be made of the main burner flames for the desired flame appearance by a qualified installer, service agency or the gas supplier. If the flames are distorted and/or there is evidence of back pressure, check the combustion and ventilation air system for blockage. If there is carbon and scale in the heat exchanger tubes, the heat exchanger assembly should be replaced.
- **IMPORTANT:** It is recommended that at the beginning of the heating season, the flame sensor be cleaned with fine steel wool or Scotch Bright Pad by a qualified installer, service agency or the gas supplier.
- **IMPORTANT:** It is recommended that an annual inspection and cleaning of all furnace markings be made to assure legibility. Attach a replacement marking, which can be obtained through the distributor, if any are found to be illegible or missing.
- **IMPORTANT:** It is recommended that the Venturi inlet filter if equipped should be removed and cleaned before each heating season and periodically during if required based on the amount of dust and lint in your area.

#### **WARNING**

**HOLES IN THE VENT PIPE OR HEAT EXCHANGER CAN CAUSE TOXIC FUMES TO ENTER THE HOME, RESULTING IN CARBON MONOXIDE POISONING OR DEATH. THE VENT PIPE OR HEAT EXCHANGER MUST BE REPLACED IF THEY LEAK.**

### REPLACEMENT PARTS

Homeowners please visit [www.rheem.com](http://www.rheem.com) for product information.

Replacement parts division visit <http://www.rheemparts.com/Catalog/>



### DIAGNOSTICS

Note:  
For detailed fault codes and troubleshooting locate the QR code on the gas furnace to download the contractor app.



### WIRING DIAGRAM

Figure 35 is a complete wiring diagram for the furnace. A wiring diagram is also available on the unit.

**FIGURE 35**

**FOR MODELS WITH UT ELECTRONIC CONTROLS 1194-200 INTEGRATED FURNACE CONTROL AND DIRECT SPARK IGNITION**

