

**38MGR
Multi-zone Outdoor Unit Ductless System
Sizes 18, 24, 30, 36 and 48**

Service Manual

TABLE OF CONTENTS

	PAGE
SAFETY CONSIDERATIONS	1
INTRODUCTION	1
MODEL/SERIAL NUMBER NOMENCLATURES	2
SPECIFICATIONS – OUTDOOR	3
COMPATIBILITY TABLE	4
DIMENSIONS – OUTDOOR	5
CLEARANCES – OUTDOOR	9
ELECTRICAL DATA	9
WIRING	10
CONNECTION DIAGRAMS	11
WIRING DIAGRAMS	13
REFRIGERATION CYCLE DIAGRAMS	20
REFRIGERANT LINES	22
SYSTEM EVACUATION AND CHARGING	23
ELECTRONIC FUNCTION	24
TROUBLESHOOTING	29
OUTDOOR UNIT DISPLAY	30
DIAGNOSIS AND SOLUTION	32
APPENDIX	62

SAFETY CONSIDERATIONS

Installing, starting up, and servicing air-conditioning equipment can be hazardous due to system pressures, electrical components, and equipment location (roofs, elevated structures, etc.).

Only trained, qualified installers and service mechanics should install, start-up, and service this equipment.

Untrained personnel can perform basic maintenance functions such as cleaning coils. All other operations should be performed by trained service personnel.

When working on the equipment, observe precautions in the literature and on tags, stickers, and labels attached to the equipment.

Follow all safety codes. Wear safety glasses and work gloves. Keep quenching cloth and fire extinguisher nearby when brazing. Use care in handling, rigging, and setting bulky equipment.

Read this manual thoroughly and follow all warnings or cautions included in literature and attached to the unit. Consult local building codes and National Electrical Code (NEC) for special requirements.

Recognize safety information. This is the safety-alert symbol . When you see this symbol on the unit and in instructions or manuals, be alert to the potential for personal injury. Understand these signal words: **DANGER**, **WARNING**, and **CAUTION**.

These words are used with the safety-alert symbol. **DANGER** identifies the most serious hazards which **will** result in severe personal injury or death. **WARNING** signifies hazards which **could** result in personal injury or death. **CAUTION** is used to identify unsafe practices which **may** result in minor personal injury or product and property damage. **NOTE** is used to highlight suggestions which **will** result in enhanced installation, reliability, or operation.



WARNING

ELECTRICAL SHOCK HAZARD

Failure to follow this warning could result in personal injury or death.

Before installing, modifying, or servicing system, main electrical disconnect switch must be in the OFF position. There may be more than 1 disconnect switch. Lock out and tag switch with a suitable warning label.



WARNING



EXPLOSION HAZARD

Failure to follow this warning could result in death, serious personal injury, and/or property damage.

Never use air or gases containing oxygen for leak testing or operating refrigerant compressors. Pressurized mixtures of air or gases containing oxygen can lead to an explosion.

CAUTION

EQUIPMENT DAMAGE HAZARD

Failure to follow this caution may result in equipment damage or improper operation.

Do not bury more than 36 in. (914 mm) of refrigerant pipe in the ground. If any section of pipe is buried, there must be a 6 in. (152 mm) vertical rise to the valve connections on the outdoor units. If more than the recommended length is buried, refrigerant may migrate to the cooler buried section during extended periods of system shutdown. This causes refrigerant slugging and could possibly damage the compressor at start-up.

INTRODUCTION

This Service Manual provides the necessary information to service, repair, and maintain the multi-zone family of heat pumps. Section 2 of this manual has an appendix with data required to perform troubleshooting. Use the Table of Contents to locate a desired topic.

MODEL/SERIAL NUMBER NOMENCLATURES

Table 1—Unit Sizes

SYSTEM TONS	kBTUh	VOLTAGE – PHASE	OUTDOOR MODEL
1.50	18	208/230–1	38MGRQ18B--3
2	24	208/230–1	38MGRQ24C--3
2.5	30	208/230–1	38MGRQ30D--3
3.00	36	208/230–1	38MGRQ36D--3
4.00	48	208/230–1	38MGRQ48E--3

INDOOR UNIT

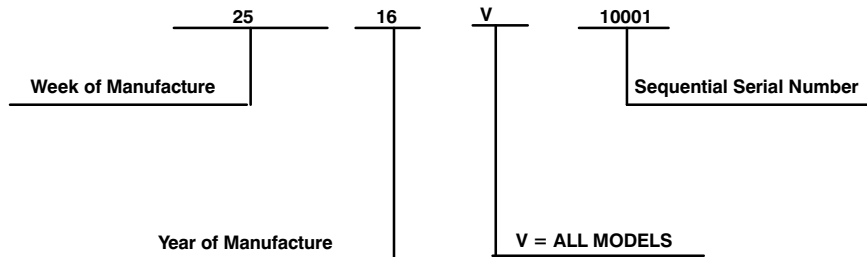
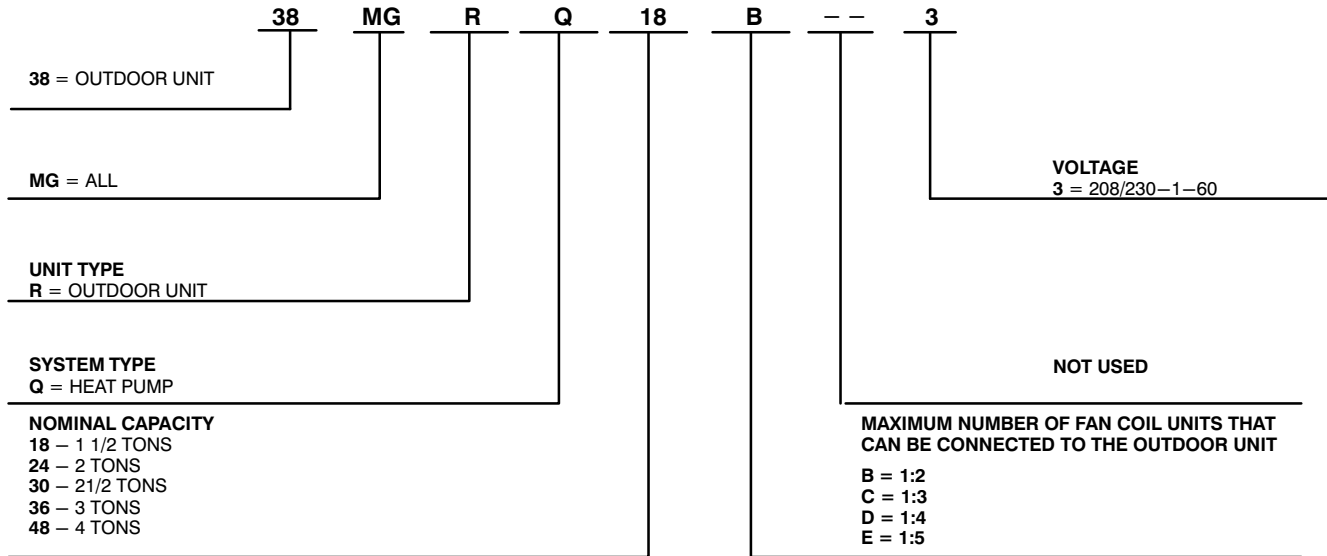

Use of the AHRI Certified TM Mark indicates a manufacturer's participation in the program. For verification of certification for individual products, go to www.ahridirectory.org.



SPECIFICATIONS – OUTDOOR

Table 2—Outdoor

		HEAT PUMP				
SYSTEM	Size	18	24	30	36	48
	Outdoor Model	38MGRQ18B---3	38MGRQ24C---3	38MGRQ30D---3	38MGRQ36D---3	38MGRQ48E---3
	Max Number of Zones	2	3	4	4	5
Performance Non-Ducted	Energy Star	YES	YES	YES	YES	YES
	Cooling System Tons	1.5	2.0	2.5	3.0	4.0
	Cooling Rated Capacity	Btu/h 18,000	24,000	30,000	36,000	48,000
	Cooling Cap. Range Min–Max	Btu/h 5810~21940	7880~33510	8090~41470	8560~45020	8560~53160
	SEER	22.5	23	23.8	21.5	22.4
	EER	12.5	12.5	12.5	13.5	12.5
	Heating Rated Capacity (47° F)	Btu/h 19,000	23,000	28,000	36,000	48,000
	Heating Rated Capacity (17° F)	Btu/h 12,000	13,600	17,400	23,200	29,600
	Heating Max. Capacity (5° F)	Btu/h 13,900	23,000	28,000	36,000	36,000
	Heating Cap. Range Min–Max	Btu/h 5760~24480	6010~36180	6350~41950	7210~50350	7210~55820
	HSPF	10.3	9.8	10.0	10.5	10.2
	COP (47° F)	W/W 3.6	3.9	3.8	3.8	3.6
COP (17° F)	W/W 2.8	2.7	2.8	2.8	2.7	
COP (5° F)	W/W 2.2	2.1	2.0	1.8	2.0	
Performance Combination Ducted and Non-Ducted	Energy Star	NO	YES	NO	NO	NO
	Cooling System Tons	1.5	1.9	2.4	3.0	4.0
	Cooling Rated Capacity	Btu/h 18,000	23,000	29,000	35,500	48,000
	Cooling Cap. Range Min–Max	Btu/h 5795~20708	7765~31955	8060~39990	8510~42635	8510~52580
	SEER	20.45	21	21.65	19.25	20
	EER	12.15	12.5	12	12.15	11.3
	Heating Rated Capacity (47° F)	Btu/h 18,750	22,000	28,000	36,000	49,000
	Heating Rated Capacity (17° F)	Btu/h 11,700	12,900	17,300	23,800	31,300
	Heating Max. Capacity (5° F)	Btu/h 14,150	22,000	28,000	35,500	36,400
	Heating Cap. Range Min–Max	Btu/h 5650~24365	5980~36190	6275~42305	7045~47800	7045~54935
	HSPF	9.9	9.9	9.5	9.9	10.2
	COP (47° F)	W/W 3.7	3.9	3.7	3.7	3.5
COP (17° F)	W/W 2.7	2.6	2.7	2.7	2.7	
COP (5° F)	W/W 2.1	2.0	2.0	1.8	1.9	
Performance Ducted	Energy Star	NO	YES	NO	NO	NO
	Cooling System Tons	1.5	1.8	2.3	2.9	4.0
	Cooling Rated Capacity	Btu/h 18,000	22,000	28,000	35,000	48,000
	Cooling Cap. Range Min–Max	Btu/h 5780~19476	7650~30400	8030~38510	8460~40250	8460~52000
	SEER	18.4	19	19.5	17	17.6
	EER	11.8	12.5	11.5	10.8	10.1
	Heating Rated Capacity (47° F)	Btu/h 18,500	21,000	28,000	36,000	50,000
	Heating Rated Capacity (17° F)	Btu/h 11,400	12,200	17,200	24,400	33,000
	Heating Max. Capacity (5° F)	Btu/h 14,400	21,000	28,000	35,000	36,800
	Heating Cap. Range Min–Max	Btu/h 5539~24249	5950~36200	6200~42660	6880~45250	6880~54050
	HSPF	9.4	8.8	9.0	9.2	10.1
	COP (47° F)	W/W 3.8	3.8	3.6	3.6	3.4
COP (17° F)	W/W 2.7	2.5	2.5	2.5	2.6	
COP (5° F)	W/W 2.1	2.0	2.0	1.7	1.8	
Operating Range	Cooling Outdoor DB Min–Max	° F(° C) -13~122 (-25~50)	-13~122 (-25~50)	-13~122 (-25~50)	-13~122 (-25~50)	-13~122 (-25~50)
	Heating Outdoor DB Min–Max	° F(° C) -22~86 (-30~30)	-22~86 (-30~30)	-22~86 (-30~30)	-22~86 (-30~30)	-22~86 (-30~30)
Piping	Total Piping Length	ft (m) 131(40)	197(60)	263(80)	328(100)	328(100)
	Piping to furthest FCU	ft (m) 82 (25)	98 (30)	115(35)	115(35)	115 (35)
	Drop (OD above ID)	ft (m) 49(15)	49(15)	49(15)	65(20)	65(20)
	Lift (OD below ID)	ft (m) 49(15)	49(15)	49(15)	65(20)	65(20)
	Pipe Connection Size–Liquid	in (mm) 1/4*2 (6.35*2)	1/4*3 (6.35*3)	1/4*4 (6.35*4)	1/4*4 (6.35*4)	1/4*5 (6.35*5)
	Pipe Connection Size–Suction	in (mm) 3/8*2 (9.52*2)	3/8*3 (9.52*3)	1/2 *1+ 3/8*3 (12.7*1+9.52*3)	1/2 *1+ 3/8*3 (12.7*1+9.52*3)	1/2 *2+ 3/8*3 (12.7*2+9.52*3)
Refrigerant	Type	R410A	R410A	R410A	R410A	R410A
	Charge	lbs (kg) 4.41 (2.0)	6.17(2.8)	6.61 (3.0)	10.13 (4.6)	10.13 (4.6)
	Metering Device	EEV	EEV	EEV	EEV	EEV
Electrical	Voltage, Phase, Cycle	V/Ph/Hz 208/230–1–60	208/230–1–60	208/230–1–60	208/230–1–60	208/230–1–60
	Power Supply	Indoor unit powered from outdoor unit				
	MCA	A. 18	25	30	35	35
Compressor	MOCOP–Fuse Rating	A. 25	35	45	50	50
	Type	Rotary Inverter	Rotary Inverter	Rotary Inverter	Rotary Inverter	Rotary Inverter
	Model	ATM150D23UFZ	ATF235D22UMT	ATF310D43UMT	ATQ360D1UMU	ATQ360D1UMU
	Oil Type	ESTER OIL VG74	ESTER OIL VG74	ESTER OIL VG74	ESTER OIL VG74	ESTER OIL VG74
	Oil Charge	Fl. Oz. 17.64	23.58	35.27	49.38	49.38
	Rated Current	RLA 10	15	19	21	21
Outdoor	Unit Width	in (mm) 37.31 (948)	41.22 (1047)	41.22 (1047)	41.15 (1045)	41.15 (1045)
	Unit Height	in (mm) 27.64 (702)	31.88 (810)	31.88 (810)	52.48 (1333)	52.48 (1333)
	Unit Depth	in (mm) 14.82 (376)	17.91 (455)	17.91 (455)	17.63 (448)	17.63 (448)
	Net Weight	lbs (kg) 105.8 (48)	149.9 (68)	156.5 (71)	221.6 (100.5)	223.8 (101.5)
	Airflow	CFM 1,390	2,130	2,130	4,500	4,500
Sound Pressure	dB(A) 62	63	62	64	64	

COMPATIBILITY TABLE

Table 3—Outdoor

INDOOR UNIT			OUTDOOR UNIT				
			38MGRQ18B--3	38MGRQ24C--3	38MGRQ30D--3	38MGRQ36D--3	38MGRQ48E--3
High Wall	40MAQB09B--3	619PEQ009BBMA	•	•	•	•	•
	40MAQB12B--3	619PEQ012BBMA	•	•	•	•	•
	40MAQB18B--3	619PEQ018BBMA		•	•	•	•
	40MAQB24B--3	619PEQ024BBMA			•	•	•
Cassette	40MBQB09C--3	619REQ009CBMA	•	•	•	•	•
	40MBQB12C--3	619REQ012CBMA	•	•	•	•	•
	40MBQB18C--3	619REQ018CBMA		•	•	•	•
Ducted	40MBQB09D--3	619REQ009DBMA	•	•	•	•	•
	40MBQB12D--3	619REQ012DBMA	•	•	•	•	•
	40MBQB18D--3	619REQ018DBMA		•	•	•	•
	40MBQB24D--3	619REQ024DBMA			•	•	•
Floor Console	40MBQB09F--3	619REQ009FBMA	•	•	•	•	•
	40MBQB12F--3	619REQ012FBMA	•	•	•	•	•

DIMENSIONS – OUTDOOR

Table 4—Dimensions

UNIT SIZE		18	24	30	36	48
Height	in (mm)	27.6 (703)	31.89 (810)	31.89 (810)	52.48 (1333)	52.48 (1333)
Width	in (mm)	33.27 (845)	37.24 (946)	37.24 (946)	41.14 (1045)	41.14 (1045)
Depth	in (mm)	13.19 (335)	15.20 (386)	15.20 (386)	14.96 (380)	14.96 (380)
Weight—Net	lbs (kg)	105.8 (48)	149.9 (68)	156.5 (71)	223.8 (101.5)	223.8 (101.5)

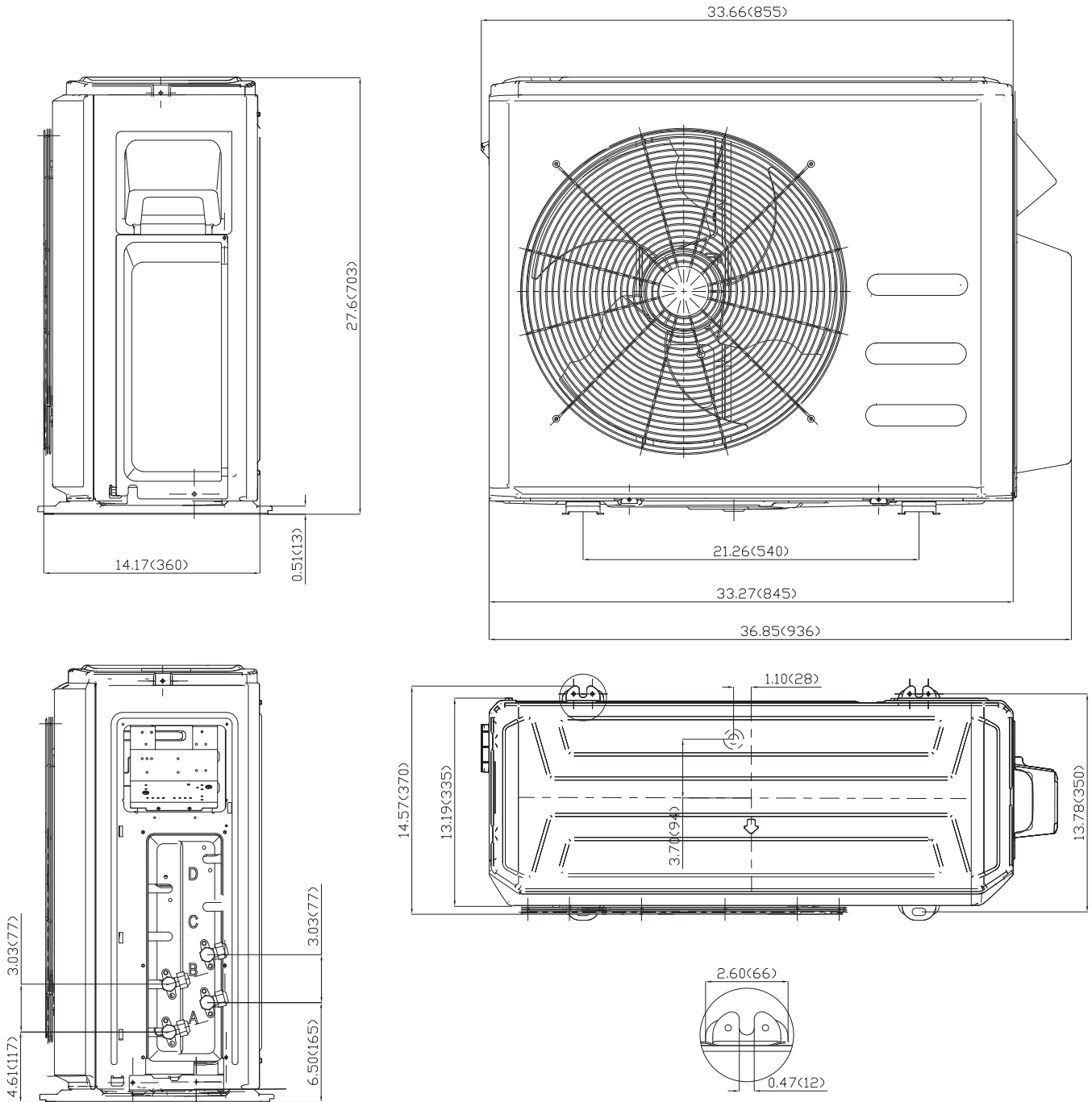

Fig. 1 – Outdoor Dimensions Size 18

NOTE: Master valves are not available on the size 18 unit.

DIMENSIONS - OUTDOOR (CONTINUED)

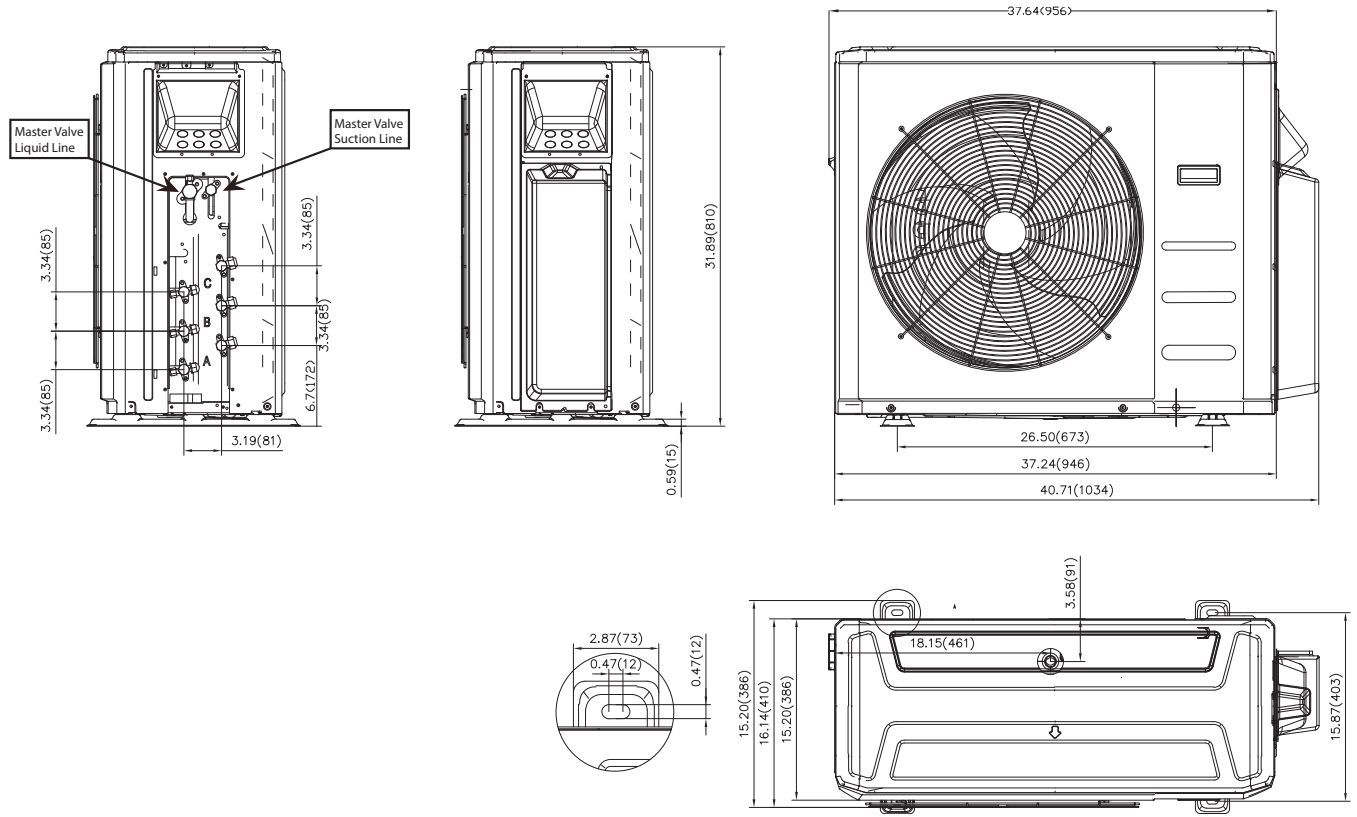

Fig. 2 – Outdoor Dimensions Size 24

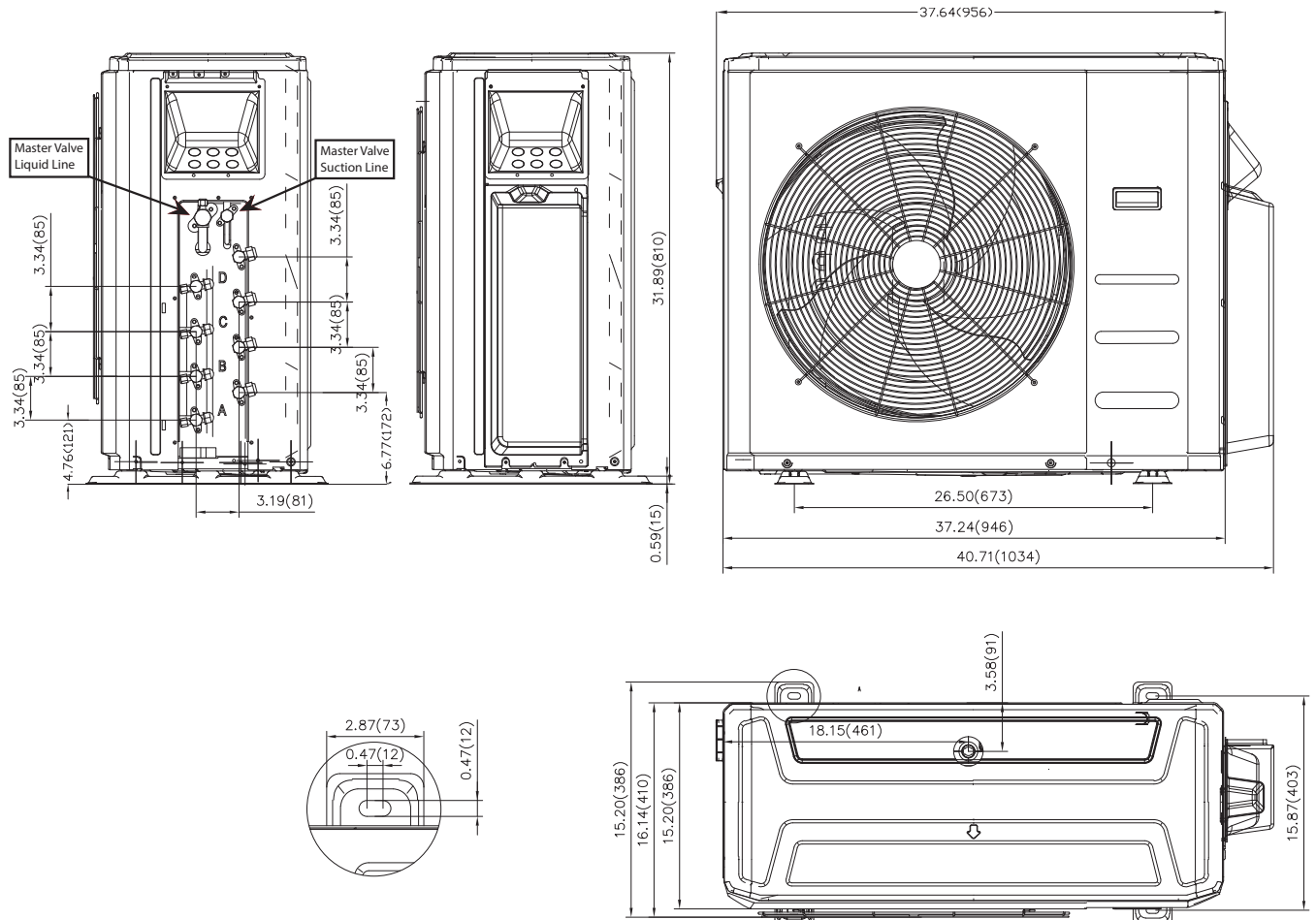

Fig. 3 – Outdoor Dimensions Size 30

DIMENSIONS - OUTDOOR (CONTINUED)

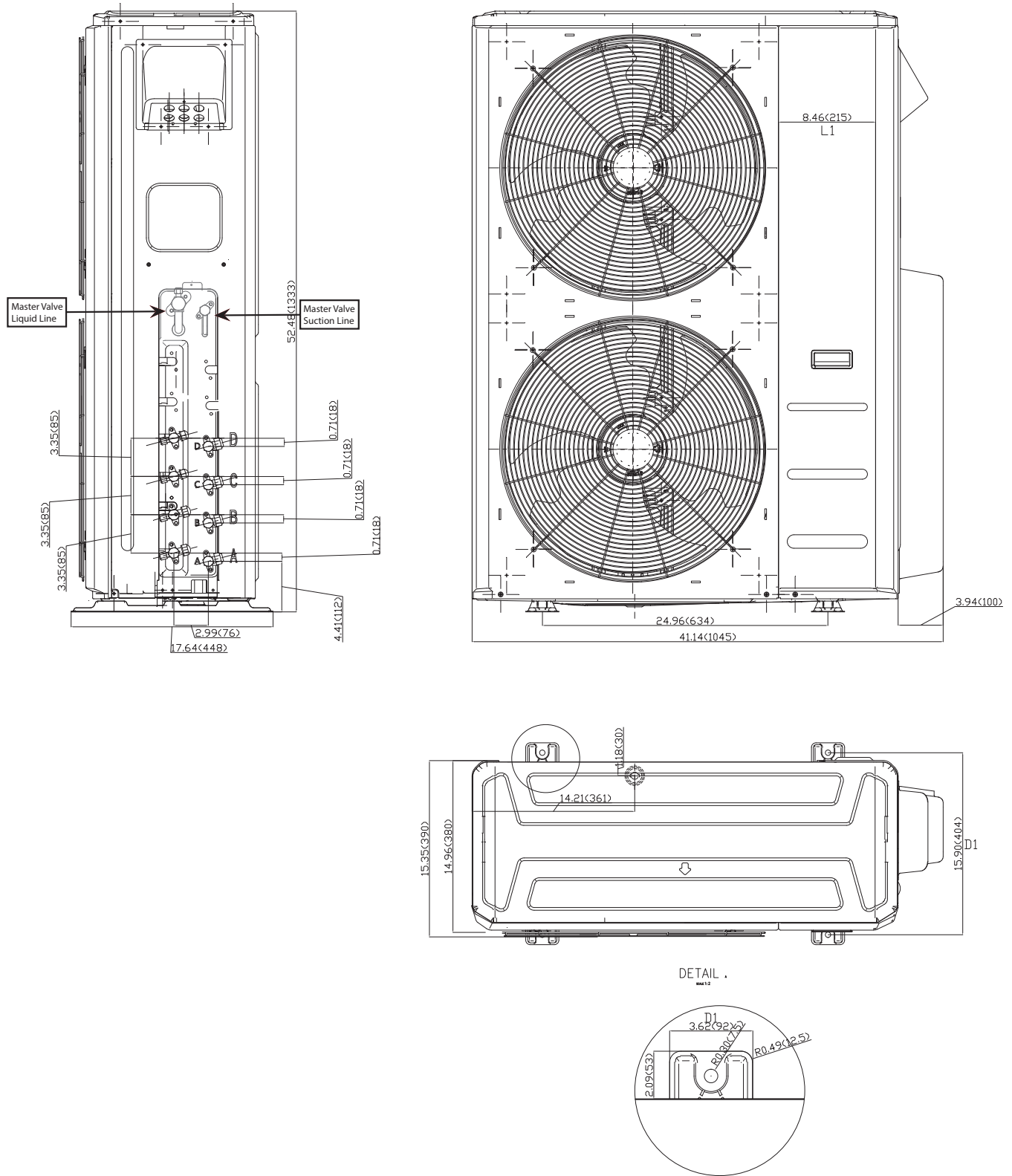

Fig. 4 – Outdoor Dimensions Size 36

DIMENSIONS - OUTDOOR (CONTINUED)

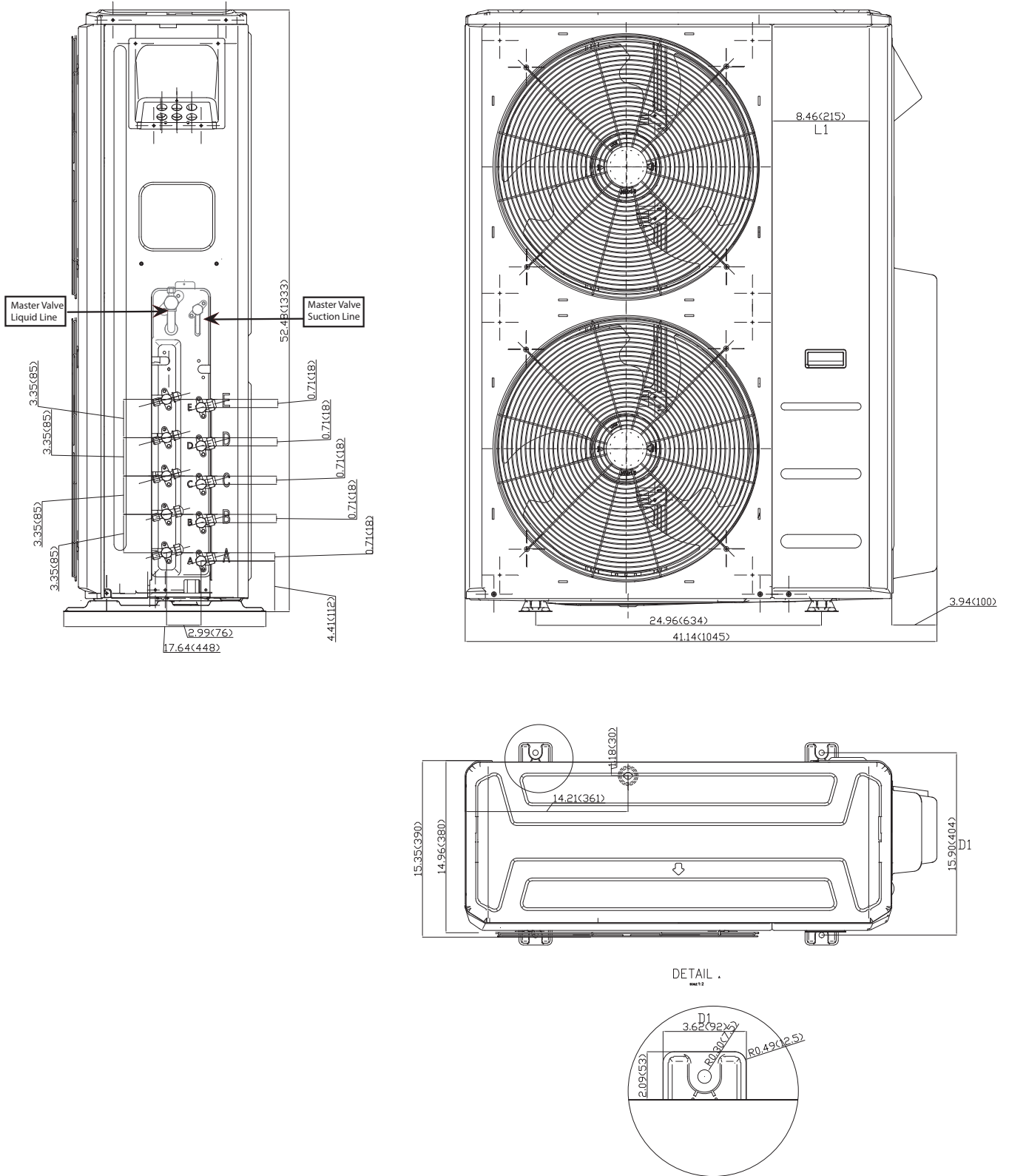

Fig. 5 – Outdoor Dimensions Size 48

CLEARANCES - OUTDOOR

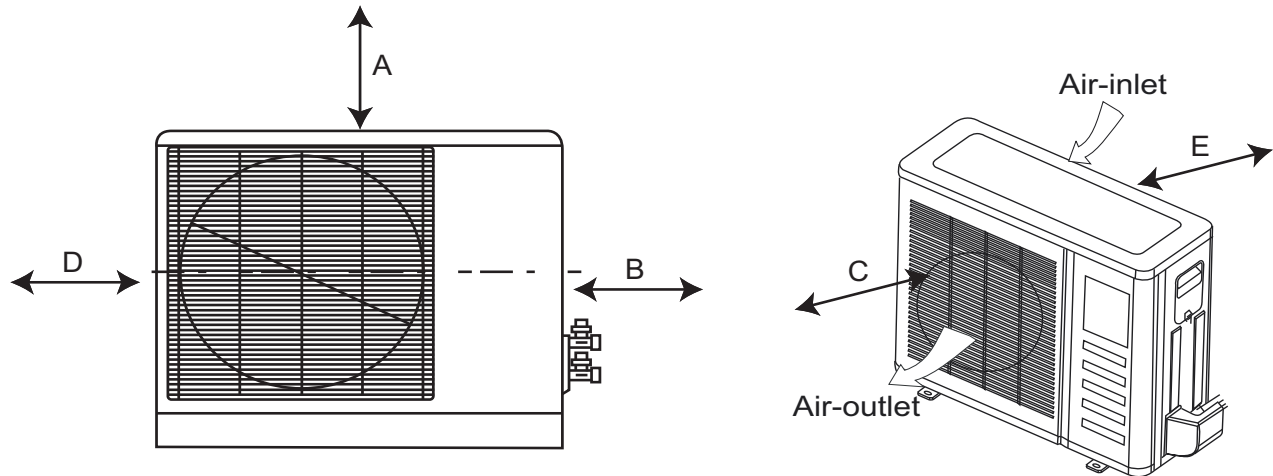

Fig. 6 – Outdoor Unit Clearance

Table 5—Outdoor

UNIT	Minimum Value in. (mm)
A	24 (609)
B	24 (609)
C	24 (609)
D	4 (101)
E	6 (152)

NOTE: Outdoor Unit must be mounted at least 2in (50mm) above the maximum anticipated snow depth.

ELECTRICAL DATA

Table 6—Multi Zone Outdoor Unit

UNIT SIZE	SYSTEM VOLTAGE	OPERATING VOLTAGE	COMPRESSOR	OUTDOOR FAN				MCA	MOCP
	VOLT / PHASE / HZ	MAX / MIN*		RLA	FLA	HP	W		
18	208-230/1/60	253 / 187	10	0.74	0.07	50	18	25	
24			15	0.9	0.16	120	25	35	
30			19	1.3	0.16	120	30	45	
36			21	1.0x2	0.11	85	35	50	
48			21	1.0x2	0.11	85	35	50	

*Permissible limits of the voltage range at which the unit will operate satisfactorily.

LEGEND

FLA - Full Load Amps
MCA - Minimum Circuit Amps
MOCP - Maximum Over Current Protection
RLA - Rated Load Amps

WIRING

All wires must be sized per NEC (National Electrical Code) or CEC (Canadian Electrical Code) and local codes. Use the Electrical Data table MCA (minimum circuit amps) and MOCP (maximum over current protection) to correctly size the wires and the disconnect fuse or breakers respectively.

Per the caution note, only stranded copper conductors with a 600 volt rating and double insulated copper wire must be used. The use of BX cable is not recommended.

Recommended Connection Method for Power and Communication Wiring –

Power and Communication Wiring:

The main power is supplied to the outdoor unit. The field supplied 14/3 power/communication wiring from the outdoor unit to the indoor unit consists of four (4) wires and provides the power for the indoor unit. Two wires are high voltage AC power, one is communication wiring and the other is a ground wire.

Recommended Connection Method for Power and Communication Wiring (To minimize communication wiring interference)

Power Wiring:

The main power is supplied to the outdoor unit. The field supplied power wiring from the outdoor unit to the indoor unit consists of three (3) wires and provides the power for the indoor unit. Two wires are high voltage AC power and one is a ground wire. To minimize voltage drop, the factory recommended wire size is 14/2 stranded with a ground.

Communication Wiring:

A separate shielded stranded copper conductor only, with a 600 volt rating and double insulated copper wire, must be used as the communication wire from the outdoor unit to the indoor unit. Please use a separate shielded 16GA stranded control wire.



CAUTION

EQUIPMENT DAMAGE HAZARD

Failure to follow this caution may result in equipment damage or improper operation.

- Wires should be sized based on NEC and local codes.
- Use copper conductors only with a minimum 600 volt rating and double insulated copper wire.



CAUTION

EQUIPMENT DAMAGE HAZARD

Failure to follow this caution may result in equipment damage or improper operation.

- Be sure to comply with local codes while running wire from the indoor unit to the outdoor unit.
- Every wire must be connected firmly. Loose wiring may cause the terminal to overheat or result in unit malfunction. A fire hazard may also exist. Therefore, ensure all wiring is tightly connected.
- No wire should be allowed to touch the refrigerant tubing, compressor or any moving parts.
- Disconnecting means must be provided and shall be located within sight and readily accessible from the air conditioner.
- Connecting cable with conduit shall be routed through a hole in the conduit panel.

CONNECTION DIAGRAMS

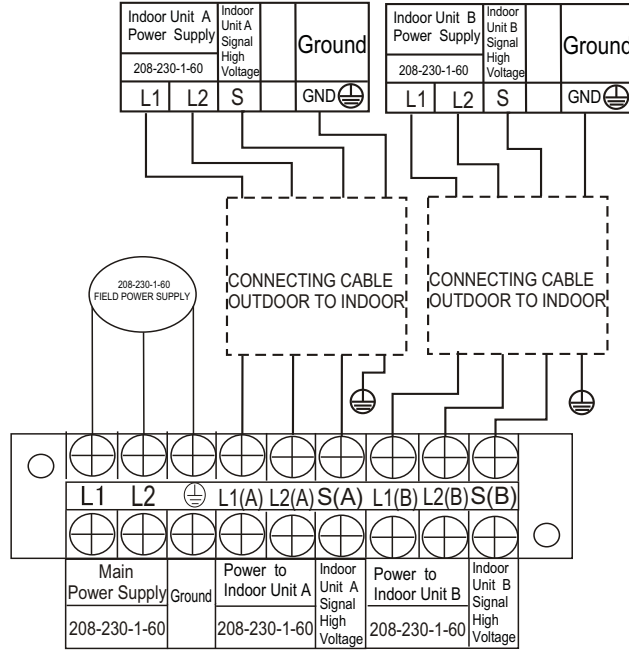

Fig. 7 – Connection Diagram Size 18K 2 Zone

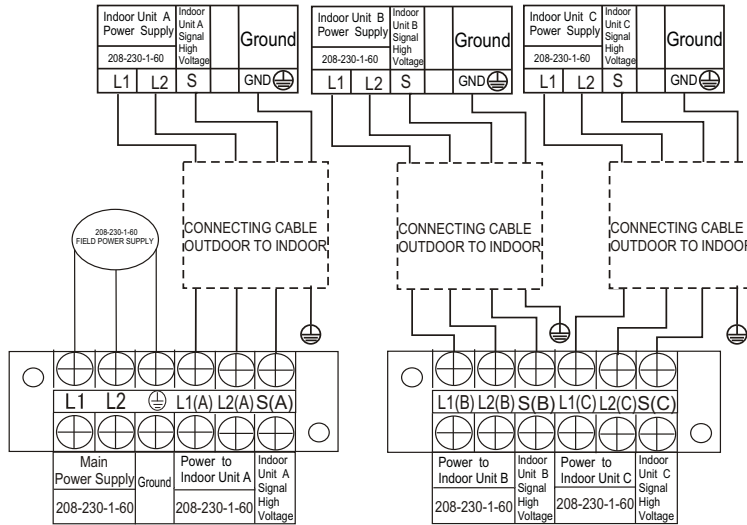

Fig. 8 – Connection Diagram Size 24K 3 Zone

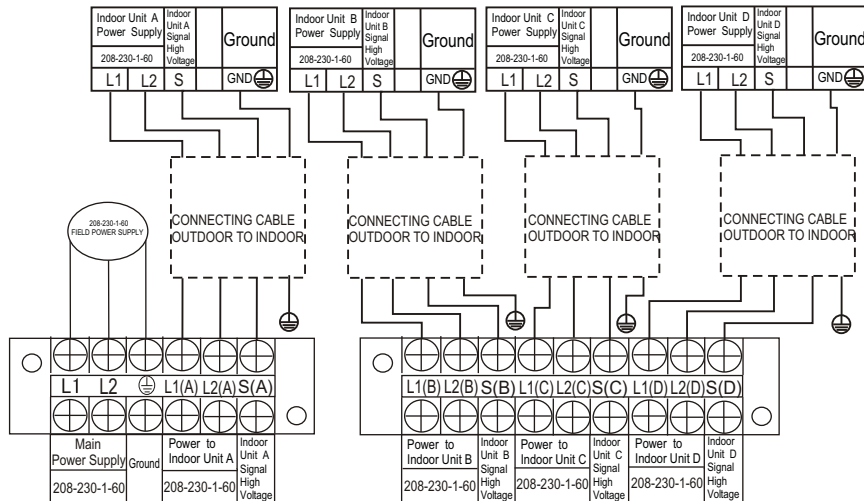

Fig. 9 – Connection Diagram Size 30K 4 Zone

CONNECTION DIAGRAMS (CONTINUED)

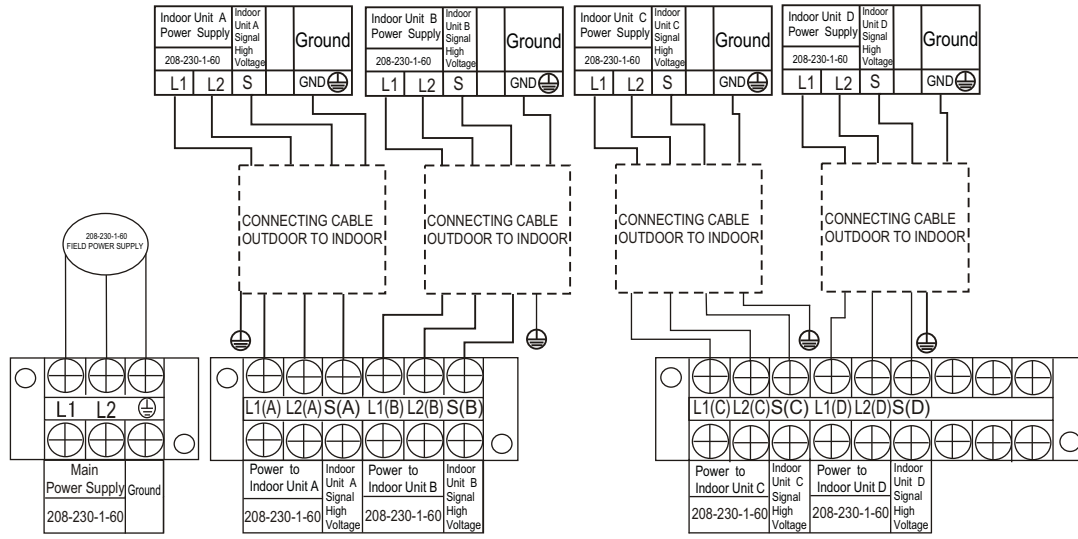

Fig. 10 – Connection Diagram Size 36K 4 Zone

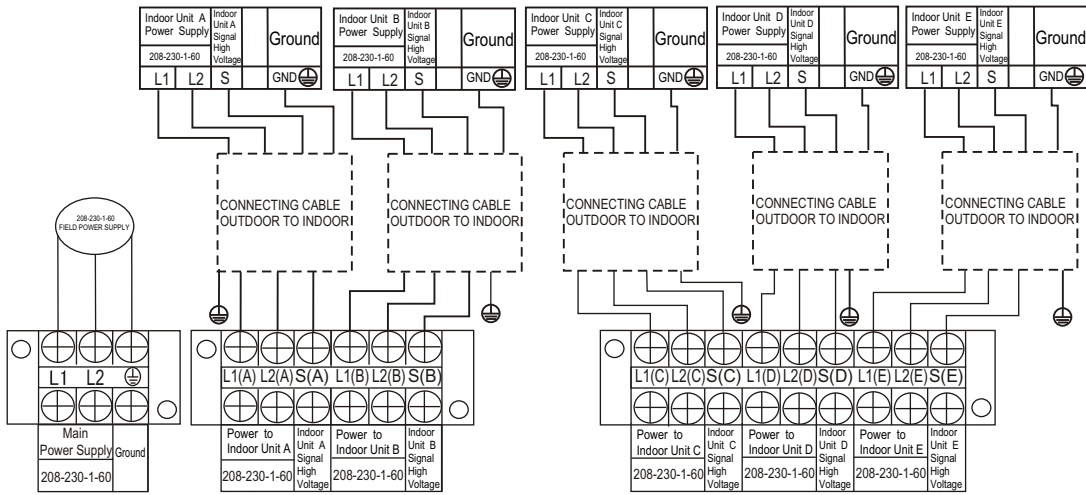

Fig. 11 – Connection Diagram Size 48K 5 Zone

WIRING DIAGRAMS

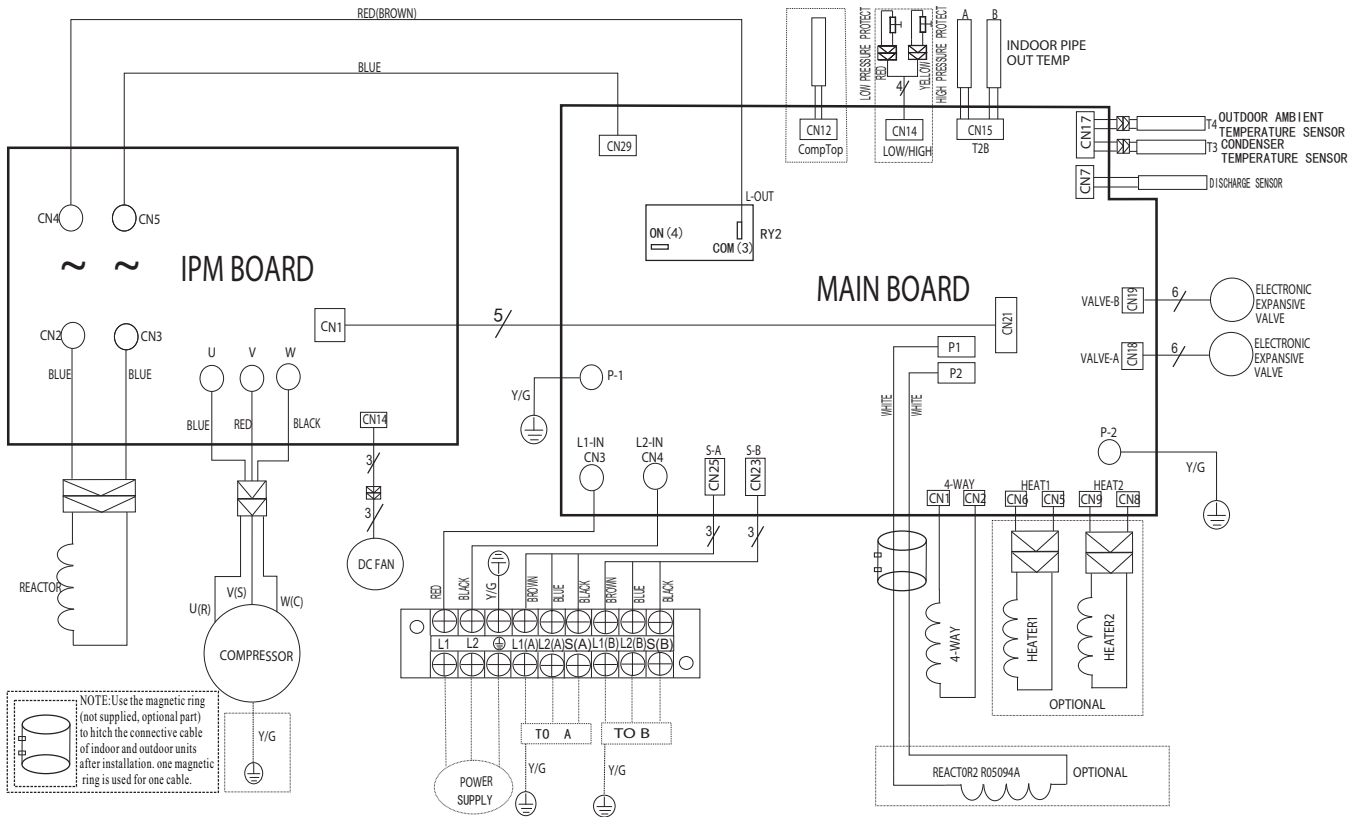

Fig. 12 – Wiring Diagram 18K – 2 Zone

Table 7—18K – 2 Zone

OUTDOOR UNIT MAIN BOARD	
CODE	PART NAME
CN3~CN4	Input: 230VAC High voltage
CN23,CN25	Output: Pin1 (Connection of the high voltage)---“S”Pin2~Pin3 (230VAC High voltage)---“L1 & L2”
P1~P2	Output: Connection of the REACTOR
CN1~CN2	Output: 230VAC High voltage----4 Way Valve
CN5~CN6	Output: 230VAC High voltage----Compressor Crankcase Heater
CN8~CN9	Output: 230VAC High voltage----Chassis Crankcase Heater
P-1~P-2	Connection to the earth
CN18, CN19	Output: Pin1–Pin4: Pulse waveform (0–12VDC), Pin5, Pin6 (12VDC)––EEV
CN7	Input:Pin1 (0–5VDC), Pin2 (5VDC)––Discharge Sensor
CN17	Input: Pin3, Pin4 (5VDC), Pin2 (0VDC), Pin1, Pin5 (0–5VDC)–Cond. and Ambient Temperature
CN15	Input: Pin1, Pin3, Pin5 (5VDC) Pin2, Pin4, Pin6 (0–5VDC)––IDU Pipe Temp
CN14	Input: Pin2, Pin4 (0VDC), Pin1, Pin3 (0–5VDC)––H/L Pressure Switches
CN12	Input: Pin1 (0–5VDC), Pin2 (5VDC)––Compressor Temp
CN29~L–OUT	Output: 230VAC High voltage––to IPM Board
CN 21	Connect to IPM BOARD

Table 8—18K – 2 Zone

OUTDOOR UNIT IPM BOARD	
CODE	PART NAME
CN4~CN5	Input: 230VAC High voltage--from the Main Board
CN2~CN3	Output: Connection of the REACTOR
U~V~W	Connection to compressor voltage among phases 0~200VAC
CN14	Connection to DC FAN
CN1	Connection to MAIN BOARD

WIRING DIAGRAMS (CONT)

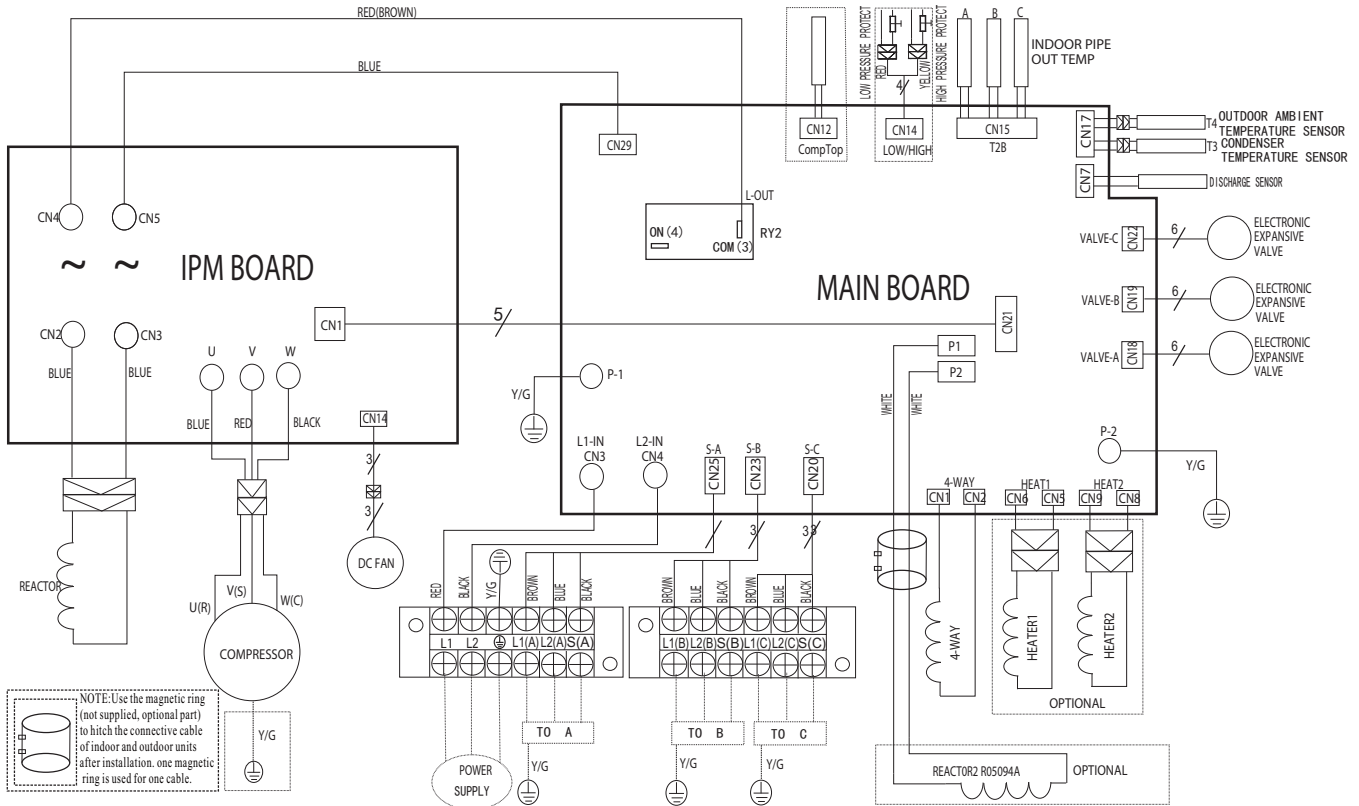

Fig. 13 – Wiring Diagrams 24K – 3 Zone Max

Table 9—24K – 3 Zone Max

OUTDOOR UNIT MAIN BOARD

CODE	PART NAME
CN3~CN4	Input: 230VAC High voltage
CN20,CN23,CN25	Output: Pin1 (Connection of the high voltage)---“S” Signal Pin2~Pin3 (230VAC High voltage)---IDU Power
P1~P2	Output: Connection of the REACTOR
CN1~CN2	Output: 230VAC High voltage---4 way Valve
CN5~CN6	Output: 230VAC High voltage---Compressor Crankcase Heater
CN8~CN9	Output: 230VAC High voltage---Chassis Crankcase Heater
P-1~P-2	Connection to the earth
CN18,CN19,CN22	Output: Pin1~Pin4: Pulse waveform (0~12VDC), Pin5, Pin6 (12VDC)---EEV
CN7	Input: Pin1 (0~5VDC), Pin2 (5VDC)--- Discharge Temp
CN17	Input: Pin3, Pin4 (5VDC), Pin2 (0VDC), Pin1, Pin5 (0~5VDC)---Conditioner and Ambient Temperature
CN15	Input: Pin1, Pin3, Pin5 (5VDC) Pin2, Pin4, Pin6 (0~5VDC)---IDU Pipe Temp
CN14	Input: Pin2, Pin4 (0VDC), Pin1, Pin3 (0~5VDC)---H/L Pressure Switch
CN12	Input: Pin1 (0~5VDC), Pin2 (5VDC)---Compressor Temp
CN29~L-OUT	Output: 230VAC High voltage to IPM Board
Cn21	Connect to the IPM BOARD

Table 10—24K – 3 Zone Max

OUTDOOR UNIT IPM BOARD

CODE	PART NAME
CN4~CN5	Input: 230VAC High voltage
CN2~CN3	Output: Connection of the REACTOR
U~V~W	Connect to compressor voltage among phases 0~200VAC
CN14	Connect to the DC FAN
CN1	Connect to the MAIN BOARD

WIRING DIAGRAMS (CONT)

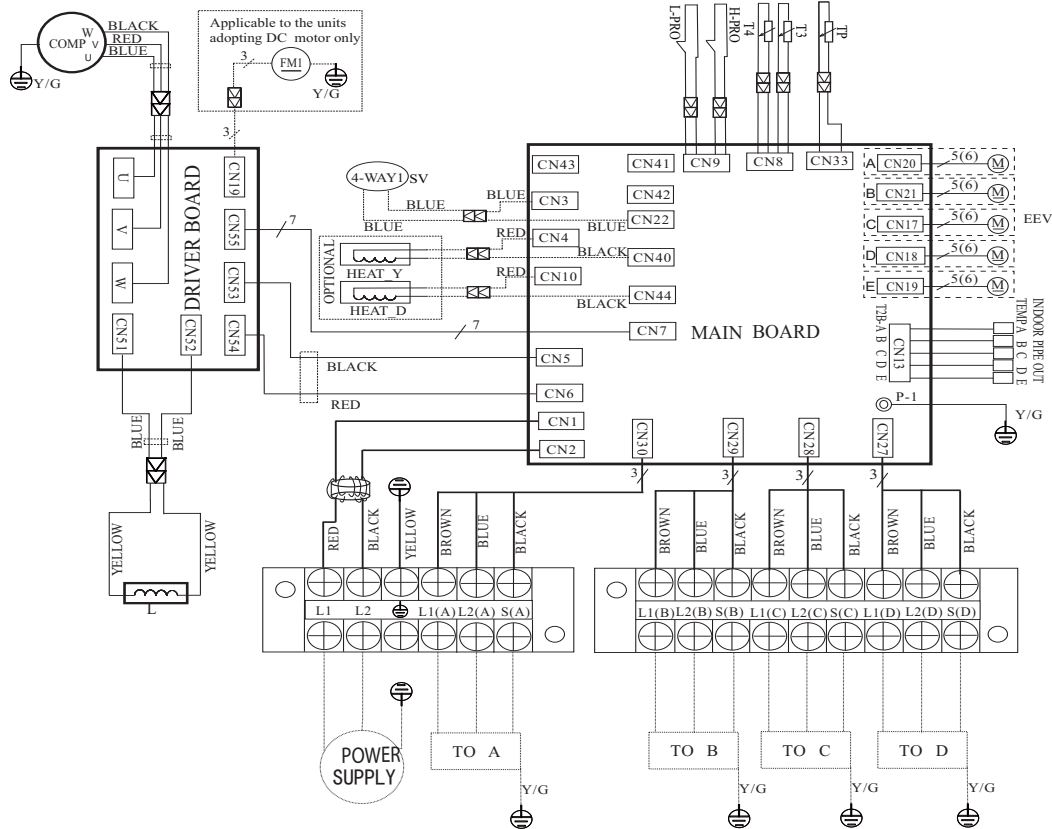

Fig. 14 – Wiring Diagrams 30K – 4 Zone Max

Table 11—30K – 4 Zone Max

OUTDOOR UNIT MAIN BOARD	
CODE	PART NAME
CN1~CN2	Input: 230VAC High voltage
CN5~CN6	Output: 230VAC High voltage
P-1	Connection to the earth
CN10~CN44	Output: 230VAC High voltage Chassis Crankcase Heater
CN4~CN40	Output: 230VAC High voltage Compressor Crankcase Heater
CN3~CN22	Output: 230VAC High voltage
CN7	Output: Pin1 (12VDC), Pin2 (5VDC), Pin3 (EARTH)
CN27~CN30	Output: Pin 2~Pin 3 (230VAC High voltage) – IDU Power & "S"
CN13	Pin1, Pin3, Pin5, Pin7, Pin9 (5VDC); Pin2, Pin4, Pin6, Pin8, Pin10 (0~5VDC)
CN33	Input: Pin1 (0~5VDC), Pin2 (5VDC) – Discharge Temp
CN8	Input: Pin3, Pin4 (5VDC), Pin2 (0VDC), Pin1, Pin5 (0~5VDC) T3 & T4
CN9	Input: Pin2, Pin4 (0VDC), Pin1, Pin3 (0~5VDC) H/L Pressure Switches

Table 12—30K – 4 Zone Max

OUTDOOR UNIT PFC & IPM BOARD	
CODE	PART NAME
CN53~CN54	Input: 230VAC High voltage
CN55	Output: Pin1 (12VDC), Pin2 (5VDC), Pin3 (EARTH)
CN19	Pin1~Pin3: Connect to FAN voltage among phases 0~200VAC
U~V~W	Connect to compressor voltage among phases 0~200VAC
CN51~CN52	CN51~EARTH, CN52~EARTH Output: 224~380VDC High voltage

Table 13—30K – 4 Zone Max

CODE	PART NAME	CODE	PART NAME
COMP	COMPRESSOR	L	PFC INDUCTOR
CAP1	FAN MOTOR CAPACITOR	L-PRO	LOW PRESSURE SWITCH
HEAT	CRANKCASE HEATING	TP	EXHAUST TEMPERATURE SENSOR
FM1	OUTDOOR DC FAN	SV	4-WAY VALVE
FAN1	OUTDOOR AC FAN	T3	CONDENSER TEMPERATURE SENSOR
EEV	ELECTRONIC EXPANSION VALVE	T4	OUTDOOR AMBIENT TEMPERATURE SENSOR
H-PRO	HIGH PRESSURE SWITCH	TH	HEATSINK TEMPERATURE SENSOR

WIRING DIAGRAMS (CONT)

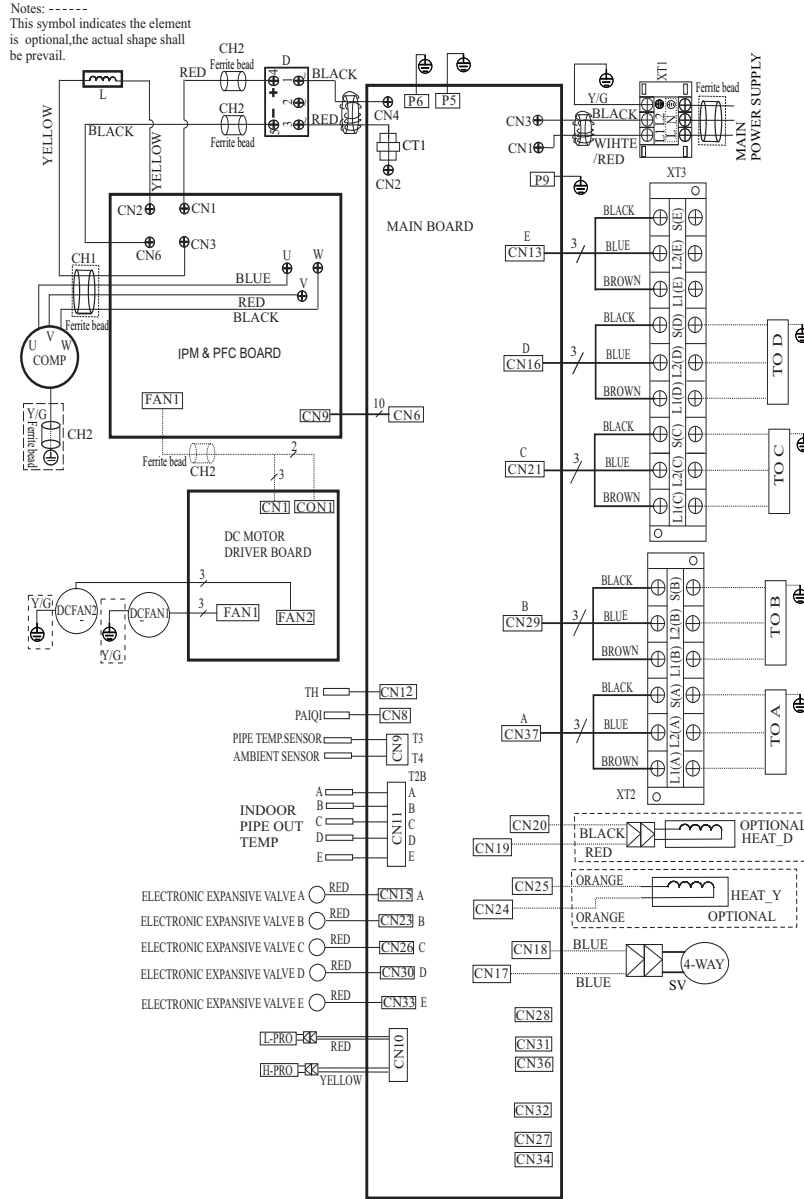

Fig. 15 – Wiring Diagrams 36K – 4 Zone Max

**Table 14—36K – 4 Zone Max
 OUTDOOR UNIT MAIN BOARD**

CODE	PART NAME
CN1~CN3	Input: 230VAC High voltage
CN13, CN16, CN21, CN29, CN37	Output: Pin1 (Connection of the high voltage) "S" Pin2~ Pin3 (230VAC High voltage) "L1&L2"
P5, P6, P9	Connection to the earth
CN22	Output: -24VDC-24VDC
CN17~CN18	Output: 230VAC High voltage to 4 way valve
CN19~CN20	Output: 230VAC High voltage Compressor Crankcase Heater
CN24~CN25	Output: 230VAC High voltage Chassis Crankcase Heater
CN11	Input: Pin1, Pin3, Pin5, Pin7, Pin9 (5VDC) Pin2, Pin4, Pin6, Pin8, Pin10 (0-5VDC) indoor pipe out sensor
CN12	Input: Pin1 (0-5VDC), Pin2 (5VDC) Heatsink Temperature Sensor
CN8	Input: Pin1 (0-5VDC), Pin2 (5VDC) Compressor top sensor (PAI/QI)
CN9	Input: Pin3, Pin4 (5VDC), Pin2 (0VDC), Pin1, Pin5 (0-5VDC) Pipe sensor and ambient sensor
CN15, CN23, CN26, CN30, CN33	Output: Pin1-Pin4: Pulse waveform (0-12VDC), Pin5, Pin6 (12VDC) to EEV
CN6	Communication: Pin1-Pin6: Pulse waveform (0-5VDC), Pin7, Pin9 (0VDC) Pin8 (0-5VDC), Pin10 (5VDC) ---to IPM & PFC board
CN2~CN4	Output: 230VAC High voltage to IPM & PFC Board
CN10	Input: Pin2, Pin4 (0VDC), Pin1, Pin3 (0-5VDC) ---H/L Pressure switch

WIRING DIAGRAMS (CONT)

Table 15—36K – 4 Zone Max

OUTDOOR UNIT PFC and IPM BOARD	
CODE	PART NAME
CN1~CN6	Output: 224~380VDC High voltage
CN2~CN6	Output: 224~380VDC High voltage
CN3~CN6	Output: 224~380VDC High voltage
U~V~W	Connect to compressor voltage among phases 0~200VAC
CN9	Communication: Pin1~Pin6: Pulse waveform (0~5VDC), Pin7, Pin9 (0VDC), Pin8 (0~5VDC), Pin10 (5VDC) to the main board
FAN1	Output: Pin1~Pin2: High voltage (224~380VDC), Pin4 (0~15VDC) Pin5 (0~5.6VDC), Pin6: Pulse waveform (0~15VDC) to drive board

Table 16—36K – 4 Zone Max

OUTDOOR UNIT DC MOTOR DRIVER BOARD	
CODE	PART NAME
CON1	Output: Pin1~Pin2:High voltage (224~380VDC)
CN1	Input:Pin4: Pulse waveform (0~15VDC), Pin3 (0~6.5VDC) Pin2 (0VDC), Pin1 (15VDC)
FAN1	Pin1~Pin3: Connect to FAN voltage among phases 0~200VAC
FAN2	Pin1~Pin3: Connect to FAN voltage among phases 0~200VAC

Table 17—36K – 4 Zone Max

CODE	PART NAME
COMP	COMPRESSOR
CAP1,CAP2	FAN MOTOR CAPACITOR
CT1	AC CURRENT DETECTOR
D	DIODE MODULE
EEV	ELECTRONIC EXPANSION VALVE
FM1, FM2	OUTDOOR DC FAN
FAN1, FAN2	OUTDOOR AC FAN
HEAT	CRANKCASE HEATING
H-PRO	HIGH PRESSURE SWITCH
L	PFC INDUCTOR
L-PRO	LOW PRESSURE SWITCH
KM	AC CONTACTOR
SV	4-WAY VALVE
TP	EXHAUST TEMPERATURE SENSOR
T3	CONDENSER TEMPERATURE SENSOR
T4	OUTDOOR AMBIENT TEMPERATURE SENSOR
TH	HEATSINK TEMPERATURE SENSOR
PAIQI	COMPRESSOR TOP SENSOR (GAS PIPE)
CH1, CH2, CH3	FERRITE BEAD

WIRING DIAGRAMS (CONT)

Notes: - - - - -

This symbol indicates the element is optional, the actual shape shall be prevail.

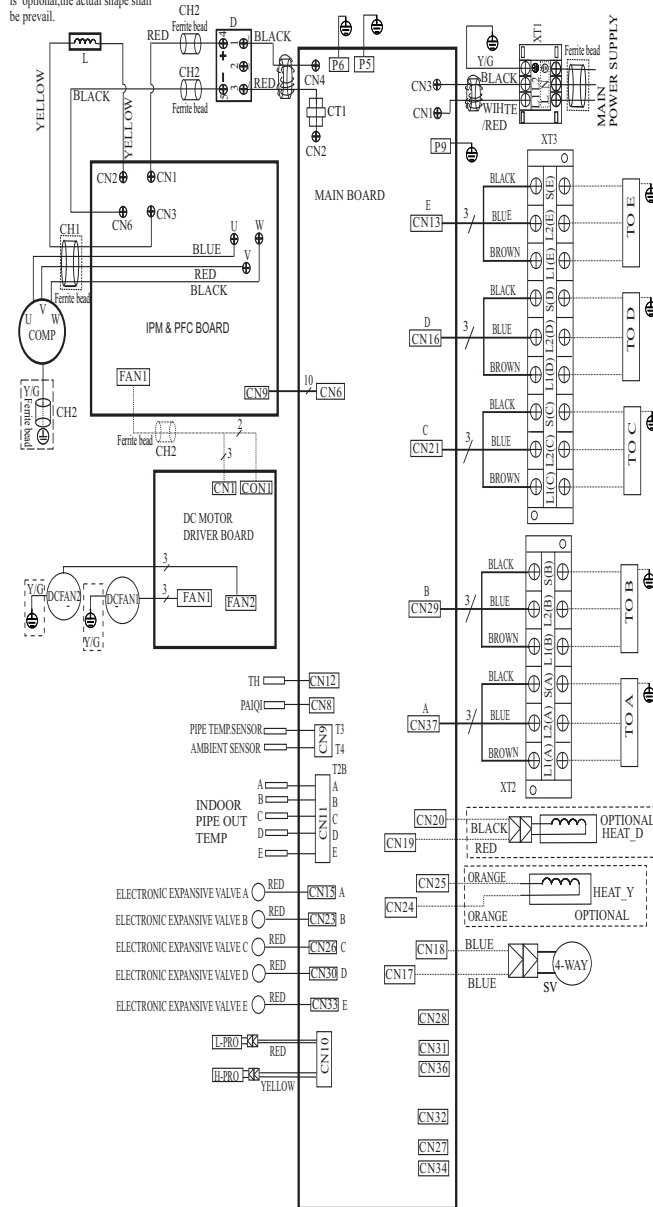

Fig. 16 – Wiring Diagrams 48K – 5 Zone Max

Table 18—48K – 5 Zone Max

OUTDOOR UNIT MAIN BOARD	
CODE	PART NAME
CN1~CN3	Input: 230VAC High voltage
CN13,CN16,CN21,CN29,CN37	Output: Pin1 (Connection of the high voltage) "S" Pin2~Pin3 (230VAC High voltage) "L1&L2"
P5,P6,P9	Connection to the earth
CN22	Output: -24VDC-24VDC
CN17~CN18	Output: 230VAC High voltage to 4 way valve
CN19~CN20	Output: 230VAC High voltage Compressor Crankcase Heater
CN24~CN25	Output: 230VAC High voltage Chassis Crankcase Heater
CN11	Input: Pin1, Pin3, Pin5, Pin7, Pin9 (5VDC) Pin2, Pin4, Pin6, Pin8, Pin10 (0-5VDC) indoor pipe out sensor
CN12	Input: Pin1 (0-5VDC), Pin2 (5VDC) Heatsink Temperature Sensor
CN8	Input: Pin1 (0-5VDC), Pin2 (5VDC) Compressor top sensor (PAIQI)
CN9	Input: Pin3, Pin4 (5VDC), Pin2 (0VDC), Pin1, Pin5 (0-5VDC) Pipe sensor and ambient sensor
CN15,CN23,CN26, CN30,CN33	Output: Pin1-Pin4: Pulse waveform (0-12VDC), Pin5, Pin6 (12VDC) to EEV
CN6	Communication: Pin1-Pin6: Pulse waveform(0-5VDC), Pin7, Pin9 (0VDC) Pin8 (0-5VDC), Pin10 (5VDC) --to IPM&PFC board
CN2~CN4	Output: 230VAC High voltage to IPM & PFC Board
CN10	Input: Pin2, Pin4 (0VDC), Pin1, Pin3 (0-5VDC) --H/L Pressure switch

WIRING DIAGRAMS (CONT)

Table 19—48K – 5 Zone Max

OUTDOOR UNIT PFC and IPM BOARD	
CODE	PART NAME
CN1~CN6	Output: 224–380VDC High voltage
CN2~CN6	Output: 224–380VDC High voltage
CN3~CN6	Output: 224–380VDC High voltage
U~V~W	Connect to compressor voltage among phases 0~200VAC
CN9	Communication: Pin1–Pin6: Pulse waveform (0–5VDC), Pin7, Pin9 (0VDC), Pin8 (0–5VDC), Pin10 (5VDC) to the main board
FAN1	Output: Pin1~Pin2: High voltage (224–380VDC), Pin4 (0–15VDC), Pin5 (0–5.6VDC), Pin6: Pulse waveform (0–15VDC) to drive board

Table 20—48K – 5 Zone Max

OUTDOOR UNIT DC MOTOR DRIVER BOARD	
CODE	PART NAME
CON1	Output: Pin1~Pin2: High voltage (224–380VDC)
CN1	Input: Pin4: Pulse waveform (0–15VDC), Pin3 (0–6.5VDC), Pin2 (0VDC), Pin1 (15VDC)
FAN1	Pin1–Pin3: Connect to FAN voltage among phases 0~200VAC
FAN2	Pin1–Pin3: Connect to FAN voltage among phases 0~200VAC

Table 21—48K – 5 Zone Max

CODE	PART NAME
COMP	COMPRESSOR
CAP1,CAP2	FAN MOTOR CAPACITOR
CT1	AC CURRENT DETECTOR
D	DIODE MODULE
EEV	ELECTRONIC EXPANSION VALVE
FM1, FM2	OUTDOOR DC FAN
FAN1,FAN2	OUTDOOR AC FAN
HEAT	CRANKCASE HEATING
H-PRO	HIGH PRESSURE SWITCH
L	PFC INDUCTOR
L-PRO	LOW PRESSURE SWITCH
KM	AC CONTACTOR
SV	4-WAY VALVE
TP	EXHAUST TEMPERATURE SENSOR
T3	CONDENSER TEMPERATURE SENSOR
T4	OUTDOOR AMBIENT TEMPERATURE SENSOR
TH	HEATSINK TEMPERATURE SENSOR
PAIQI	COMPRESSOR TOP SENSOR (GAS PIPE)
CH 1, CH 2, CH 3	FERRITE BEAD

REFRIGERATION CYCLE DIAGRAMS

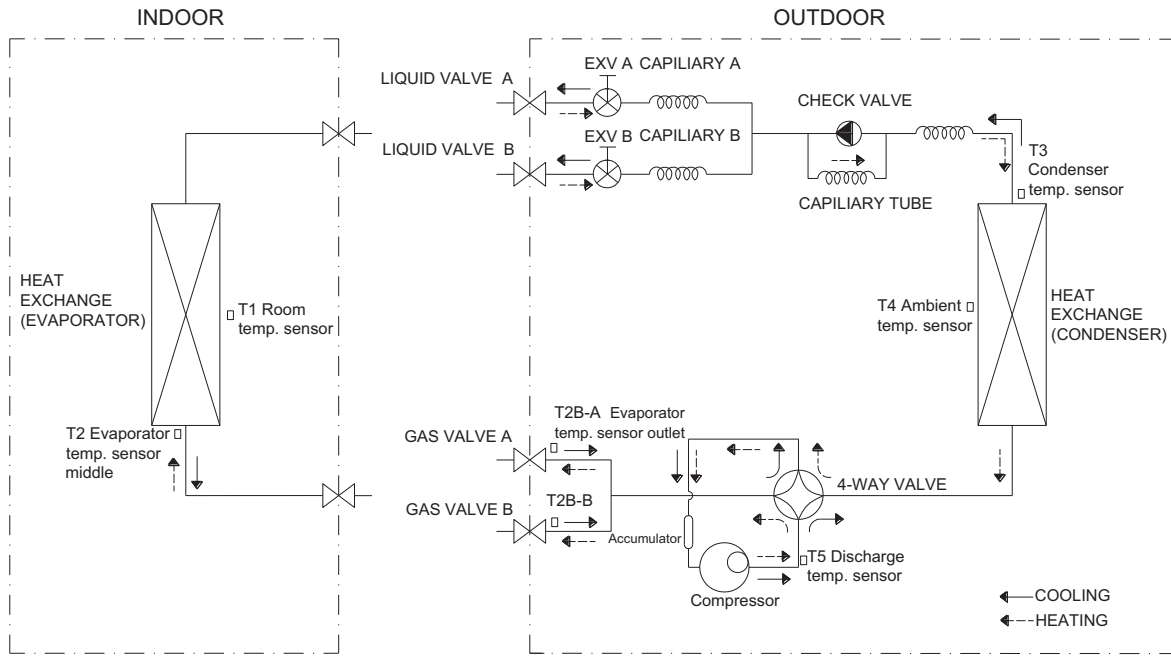

Fig. 17 – Refrigeration Cycle Diagram Size 18

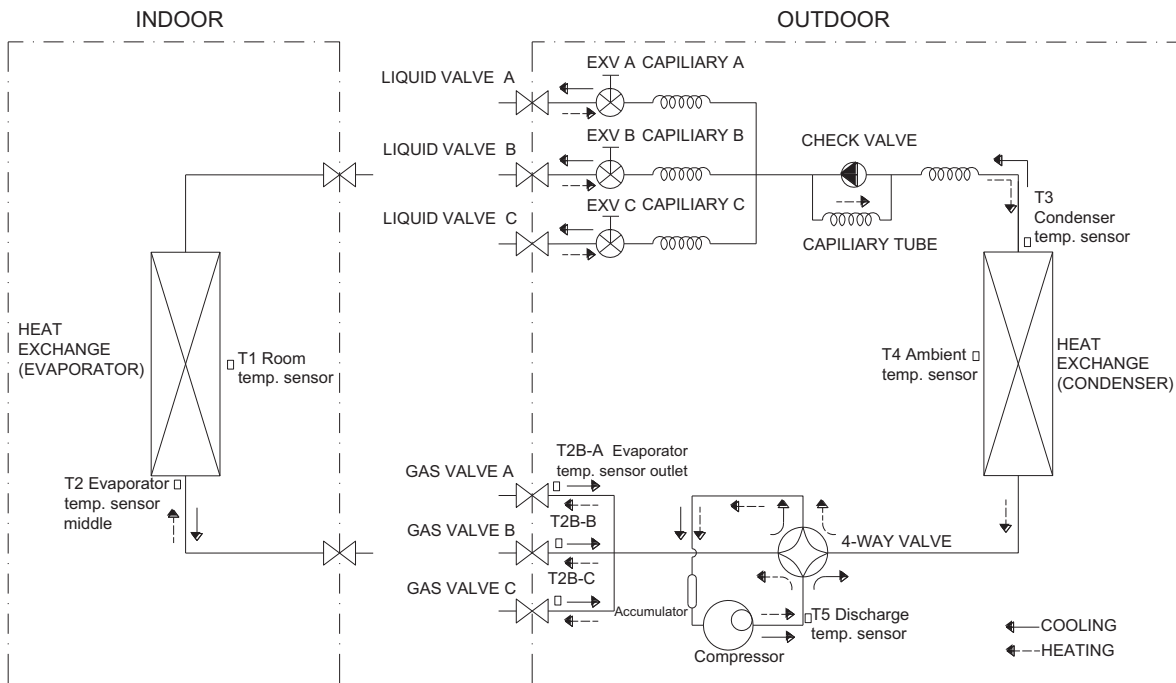

Fig. 18 – Refrigeration Cycle Diagram Size 24

REFRIGERATION CYCLE DIAGRAMS (CONTINUED)

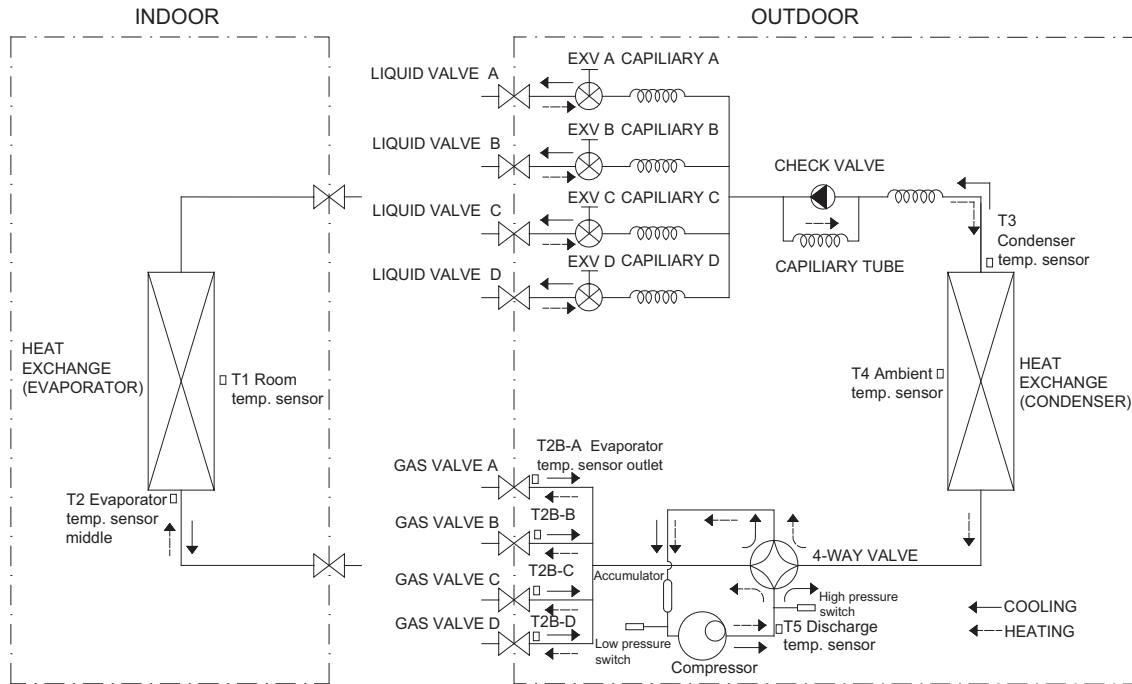

Fig. 19 – Refrigeration Cycle Diagram Sizes 30 and 36

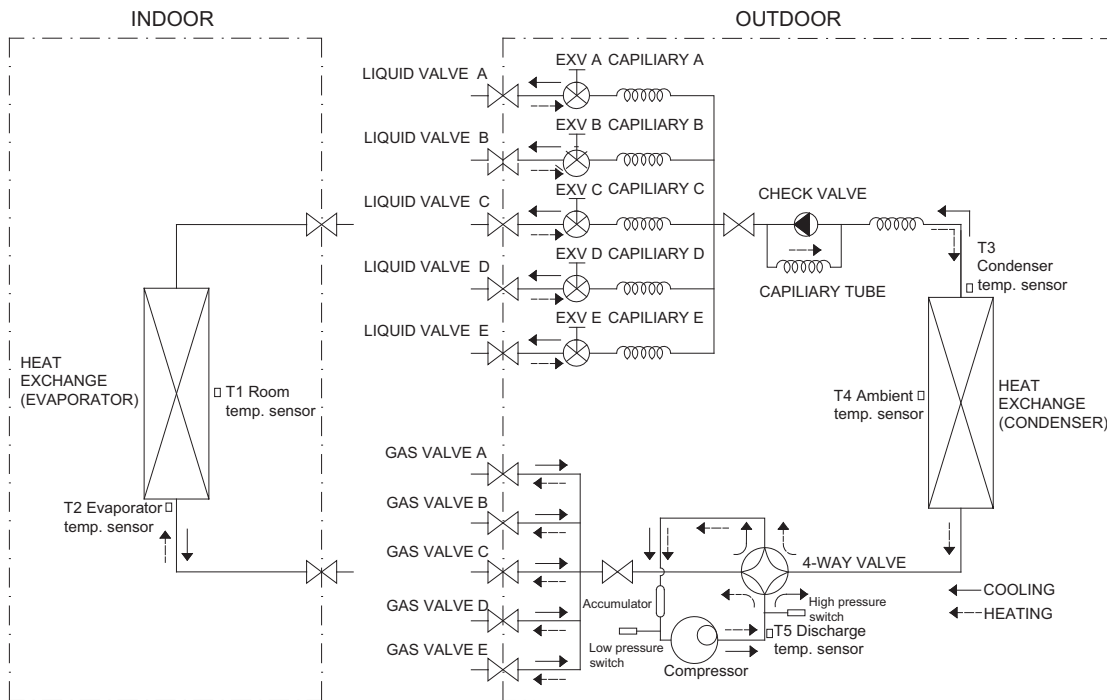

Fig. 20 – Refrigeration Cycle Diagram Size 48

REFRIGERANT LINES

General refrigerant line sizing:

- 1 The outdoor units are shipped with a full charge of R410A refrigerant. All charges, line sizing, and capacities are based on runs of 25 ft. (7.6 m) per number of zones. For runs over 25 ft. (7.6 m), consult long-line section on this page for proper charge adjustments.
- 2 Minimum refrigerant line length between the indoor and outdoor units is 10 ft. (3 m).

- 3 Refrigerant lines should not be buried in the ground. If it is necessary to bury the lines, not more than 36-in (914 mm) should be buried. Provide a minimum 6-in (152 mm) vertical rise to the service valves to prevent refrigerant migration.
- 4 Both lines must be insulated. Use a minimum of 1/2-in. (12.7 mm) thick insulation. Closed-cell insulation is recommended in all long-line applications.
- 5 Special consideration should be given to isolating interconnecting tubing from the building structure. Isolate the tubing so that vibration or noise is not transmitted into the structure.

IMPORTANT: Both refrigerant lines must be insulated separately.

- The following maximum lengths are allowed:

Table 22—Piping and Refrigerant

SYSTEM SIZE			18K	24K	30K	36K	48K
Piping	Min. Piping Length per each indoor unit	ft (m)	10 (3)	10 (3)	10 (3)	10 (3)	10 (3)
	Standard Piping Length per each indoor unit	ft (m)	25 (7.5)	25 (7.5)	25 (7.5)	25 (7.5)	25 (7.5)
	Max. outdoor–indoor height difference (OU higher than IU)	ft (m)	49 (15)	49 (15)	49 (15)	65 (20)	65 (20)
	Max. outdoor–indoor height difference (IU higher than OU)	ft (m)	49 (15)	49 (15)	49 (15)	65 (20)	65 (20)
	Max. height different between indoor units	ft (m)	32 (10)	32 (10)	32 (10)	32 (10)	32 (10)
	Max. Length per each indoor unit	ft (m)	82 (25)	98 (30)	115 (35)	115 (35)	115 (35)
	Max. Piping Length with no additional refrigerant charge per System (Standard Piping length x No. of Zones)	ft (m)	49 (15)	74 (22.5)	98 (30)	123 (37.5)	123 (37.5)
	Total Maximum Piping Length per system	ft (m)	131 (40)	197 (60)	263 (80)	328 (100)	328 (100)
	Additional refrigerant charge (between Standard – Max piping length)	Oz/ft (g/m)	0.16 (15)	0.16 (15)	0.16 (15)	0.16 (15)	0.16 (15)
	Suction Pipe Size	in (mm)	3/8*2 (9.5*2)	3/8*3 (9.5*3)	1/2*1+3/8*3 (12.7*1+9.5*3)	1/2 *2+3/8*2 (12.7*2+9.5*2)	1/2 *2+3/8*3 (12.7*2+9.5*3)
Liquid Pipe Size	in (mm)	1/4 *2 (6.3*2)	1/4 *3 (6.3*3)	1/4 *4 (6.3*4)	1/4 *4 (6.3*4)	1/4 *5 (6.3*5)	
Refrigerant	Refrigerant Type		R410A	R410A	R410A	R410A	R410A
	Charge Amount	Lbs (kg)	4.41 (2.0)	6.17 (2.8)	6.61 (3.0)	10.14 (4.6)	10.14 (4.6)

NOTE: The refrigerant charge included is adequate for the outdoor unit’s maximum number of zones multiplied by the standard piping length per zone.

Long Line Applications.:

- 1 No change in line sizing is required.
- 2 Add refrigerant per Table 23.

Table 23—Additional Charge Table Per Zone

UNIT SIZE	ZONES	CHARGE oz. (kg.)	ADDITIONAL CHARGE REQUIRED AFTER ft. (m)	ADDITIONAL CHARGE oz./ft. (g/m)	TOTAL MAXIMUM PIPING LENGTH ft. (m.)
18	2	70.55 (2.0)	49 (15)	0.16 (15)	131 (40)
24	3	98.76 (2.8)	74 (22.5)	0.16 (15)	197 (60)
30	4	105.82 (3.0)	98 (30)	0.16 (15)	263 (80)
36	4	162.26 (4.6)	123 (37.5)	0.16 (15)	328 (100)
48	5	162.26 (4.6)	123 (37.5)	0.16 (15)	328 (100)

SYSTEM EVACUATION AND CHARGING

⚠ **CAUTION**

UNIT DAMAGE HAZARD

Failure to follow this caution may result in equipment damage or improper operation.

Never use the system compressor as a vacuum pump.

Refrigerant tubes and indoor coil should be evacuated using the recommended deep vacuum method of 500 microns. The alternate triple evacuation method may be used if the following procedure is followed. Always break a vacuum with dry nitrogen.

NOTE: All units (except the 18,000 BTU model) have a Master Suction and Liquid Line Service Valve.

System Vacuum and Charge

Using Vacuum Pump

- 1 Completely tighten the flare nuts (A, B, C, D, E). Fully open all circuits service valves. Connect the manifold gage charge hose to the charge port of the low side Master service valve to evacuate all circuits at the same time (see Fig. 21).
- 2 Connect charge hose to vacuum pump.
- 3 Fully open the low side of manifold gage (see Fig. 22).
- 4 Start vacuum pump
- 5 Evacuate using the triple evacuation method.
- 6 After evacuation is complete, fully close the low side of manifold gage and stop operation of vacuum pump.
- 7 The factory charge contained in the outdoor unit is good for up to 25ft. (8 m) of line length. For refrigerant lines longer than 25ft. (8 m), add refrigerant as specified in the *ADDITIONAL REFRIGERANT CHARGE* table in this document.
- 8 Disconnect charge hose from charge connection of the low side service valve.
- 9 Securely tighten caps of service valves.

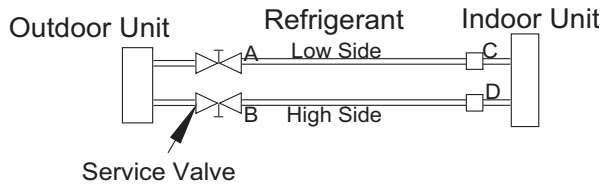

Fig. 21 – Service Valve

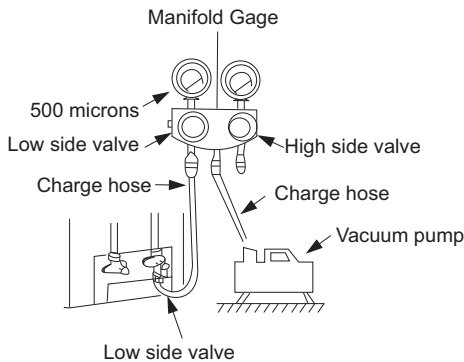

Fig. 22 – Manifold

Deep Vacuum Method

The deep vacuum method requires a vacuum pump capable of pulling a vacuum of 500 microns and a vacuum gage capable of accurately measuring this vacuum depth. The deep vacuum method is the most positive way of assuring a system is free of air and liquid water (see Fig. 23).

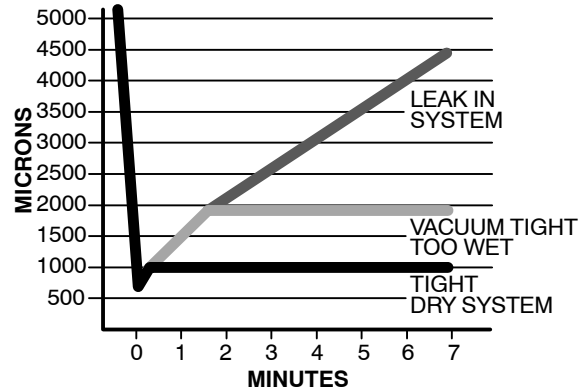

Fig. 23 – Deep Vacuum Graph

Triple Evacuation Method

The triple evacuation method should be used. Refer to Fig. 24 and proceed as follows:

- 1 Pump system down to 500 MICRONS of mercury and allow pump to continue operating for an additional 15 minutes. Unit must maintain 500 microns or less for 30 minutes or more to ensure a dry system.
- 2 Close service valves and shut off vacuum pump.
- 3 Connect a nitrogen cylinder and regulator to system and open until system pressure is 2 psig.
- 4 Close service valve and allow system to stand for 10 minutes. During this time, dry nitrogen will be able to diffuse throughout the system absorbing moisture.
- 5 Repeat this procedure as indicated in Fig. 24. System will then be free of any contaminants and water vapor.

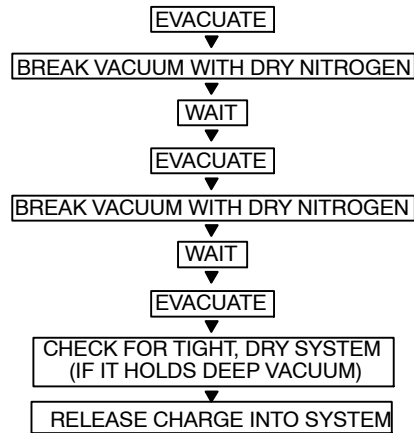

Fig. 24 – Triple Evacuation Method

Final Tubing Check

IMPORTANT: Check to be certain factory tubing on both indoor and outdoor unit has not shifted during shipment. Ensure tubes are not rubbing against each other or any sheet metal. Pay close attention to feeder tubes, making sure wire ties on feeder tubes are secure and tight.

ELECTRONIC FUNCTION

Abbreviation

- T1: Indoor ambient temperature
- T2: Middle indoor heat exchanger coil temperature
- T2B: Indoor heat exchanger exhaust coil temperature (located on the outdoor unit)
- T3: Outdoor heat exchanger pipe temperature
- T4: Outdoor ambient temperature
- T5: Compressor discharge temperature

Electric Control Working Environment

- Input voltage: 230V
- Input power frequency: 60Hz
- Indoor fan standard working amp.: <1A
- Outdoor fan standard working amp.: <1.5A.
- Four-way valve standard amp.: <1A.

Main Protection

Compressor Restart Delay

The compressor takes 1 minute to start up the first time. Further restarts take 3 minutes.

Compressor Discharge Temperature Protection

When the compressor's discharge temperature rises, the running frequency is limited according to the following rules:

- If 221°F (105°C) \cong $T5 < 230^{\circ}\text{F}$ (110°C), maintain the current frequency.
- If the temperature increases and $T5 \cong 230^{\circ}\text{F}$ (110°C), decrease the frequency to a lower level every 2 minutes until F1.
- If $T5 \cong 239^{\circ}\text{F}$ (115°C) for 10 seconds, the compressor stops and then restarts until $T5 < 194^{\circ}\text{F}$ (90°C).

Fan Speed Malfunction

If the outdoor fan speed is lower than 100RPM or higher than 2400RPM for 60 seconds or more, the unit stops and the LED displays an E8 failure code.

Inverter Module Protection

The inverter protection module ensures that faults related to current, voltage, or temperature do not damage the inverter.

Low Voltage Protection

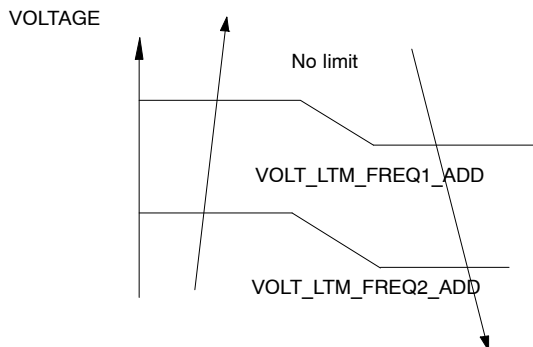

Fig. 25 – Low Voltage Protection

If these protections are triggered, the A/C unit stops and the LED displays the failure code. The unit restarts 3 minutes after the protection mechanism turns off.

NOTE: If the low voltage protection triggers and the voltage does not restore to normal within 3 minutes, the protection remains active even after a machine restart.

Compressor Current Limit Protection

The temperature interval for the current limit is the same as the range of the T4 frequency limit.

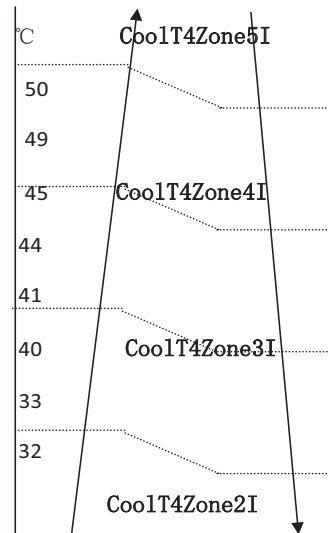

Fig. 26 – Cooling Mode

Table 24— Cooling Mode

CoolReturnI	Difference between current limit and shutdown current
CoolT4Zone5I	Cooling $T4 \geq 50^{\circ}\text{C}$ current limit value
CoolT4Zone4I	Cooling $49 > T4 \geq 45^{\circ}\text{C}$ current limit value
CoolT4Zone3I	Cooling $44 > T4 \geq 41^{\circ}\text{C}$ current limit value
CoolT4Zone2I	Cooling $40 > T4 \geq 33^{\circ}\text{C}$ current limit value
CoolT4Zone1I	Cooling $32 > T4$ current limit value
CoolStopI	Cooling stop protection current value

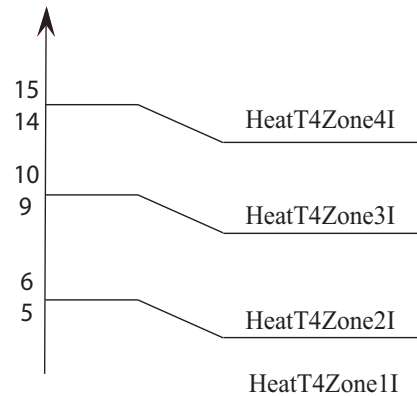

Fig. 27 – Heating Mode

Table 25—Heating Mode

HeatReturnI	Difference between current limit and shutdown current
HeatT4Zone4I	Heating $T4 \geq 15^{\circ}\text{C}$ current limit value
HeatT4Zone3I	Heating $14 > T4 \geq 10^{\circ}\text{C}$ current limit value
HeatT4Zone2I	Heating $9 > T4 \geq 6^{\circ}\text{C}$ current limit value
HeatT4Zone1I	Heating $5 > T4$ current limit value
HeatStopI	Heating stop protection current value

Indoor / Outdoor Units Communication Protection

If the indoor units do not receive the feedback signal from the outdoor units for 2 consecutive minutes, the unit stops and displays a failure code.

High Condenser Coil Temperature Protection

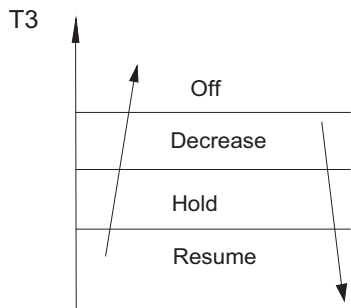

Fig. 28 – High Condenser Coil Temperature Protection

Outdoor Unit Anti-Freezing Protection

When $T2 < 39^{\circ}\text{F}$ (4°C) for 250 seconds or $T2 < 32^{\circ}\text{F}$ (0°C), the indoor unit capacity demand is zero and resumes the normal operation when $T2 > 46.4^{\circ}\text{F}$ (8°C) and the protection time is no less than 3 minutes.

Oil Return

Rules for Operation:

- 1 If the compressor frequency remains lower than the frequency set for the setting time, the unit raises the frequency to the frequency set for the setting time and then resumes the former frequency.
- 2 The EXV continues at 300p while the indoor units maintain their operation. If the outdoor ambient temperature is higher than the set frequency during the oil return, the unit stops the oil return process.

Low Outdoor Ambient Temperature Protection

When the compressor is off and $T4$ is lower than -31°F (-35°C) for 10 seconds, the unit stops and displays “LP.”

When the compressor is on and $T4$ remains lower than -40°F (-40°C) for 10 seconds, the unit stops and displays “LP.”

When $T4$ is no lower than -25.6°F (-32°C) for 10 seconds, the unit exits protection.

Controls and Functions

Capacity Request Calculation

Cooling Mode:

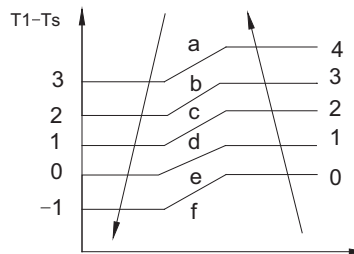

Fig. 29 – Cooling Mode

Table 26—Cooling Mode

Capacity Area	a	b	c	d	e	f
Norm code (N)	3	2	1.5	1	0.5	0

Table 27—Cooling Mode

Model	9K	12K	18K	24K
HP	1.0	1.2	1.5	2.5

NOTE: The final result is an integer.

Use Table 28 and the final capacity request to confirm the operating frequency.

Table 28—Cooling Mode

Frequency (Hz)	0	COOL_F1	COOL_F2	...	COOL_F24	COOL_F25
Amendatory Capacity Demand	0	1	2	...	24	25

The maximum running frequency is adjusted according to the outdoor ambient temperature.

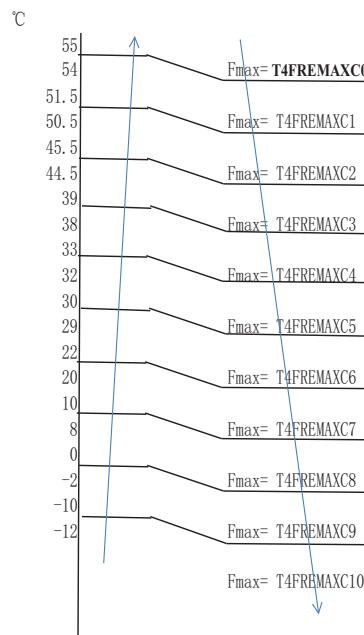

Fig. 30 – Maximum Running Frequency

Heating Mode

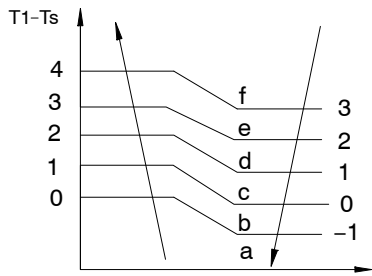

Fig. 31 – Heating Mode

Table 29—Heating Mode

Capacity Area	a	b	c	d	e	f
Norm code (N)	3	2	1.5	1	0.5	0

Table 30—Heating Mode

Model	9K	12K	18K	24K
HP	1.0	1.2	1.5	2.5

NOTE: The final result is an integer.

Modify the result according to a T2 average (correction).

NOTE: Average value of T2; sum of T2 value of all indoor units)/(indoor units number.

°C T2 average

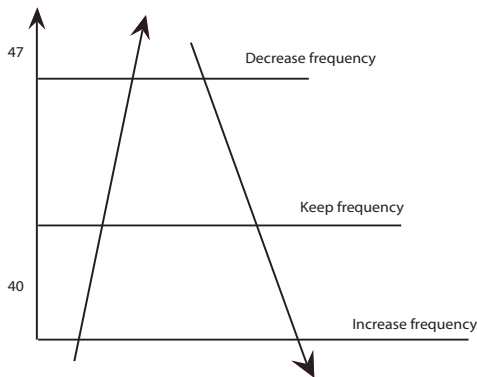

Fig. 32 – T2 Average

Use Table 31 and the final capacity request to confirm the operating frequency.

Table 31—T2 Average

Frequency (Hz)	0	HEAT_F1	HEAT_F2	...	HEAT_F24	HEAT_F25
Amendatory Capacity Demand	0	1	2	...	24	25

The maximum running frequency is adjusted according to the outdoor ambient temperature.

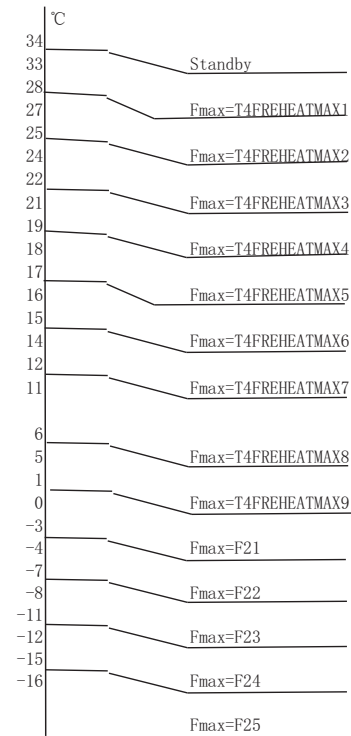

Fig. 33 – T2 Average

Defrosting Control

Defrosting Conditions

After the compressor starts and enters a normal operation, mark the minimum value of T3 from the 10th to the 15th minute as T30.

If any one of the following conditions is satisfied, the unit enters the Defrosting mode:

- 1 If the compressor's cumulative running time reaches 29 minutes and $T3 < TCDI1$ and $T3 + T30SUBT3ONE \leq T30$.
- 2 If the compressor cumulative running time reaches 35 minutes and $T3 < TCDI2$ and $T3 + T30SUBT3TWO \leq T30$.
- 3 If the compressor cumulative running time reaches 40 minutes and $T3 < -24C$ for 3 minutes.
- 4 If the compressor cumulative running time reaches 120 minutes and $T3 < -15^{\circ}C$.

Defrost Stop Conditions

If any of the following conditions is satisfied, defrosting ends and the unit returns to the normal heating mode:

- T3 rises above than TCDE1 °C
- T3 remains at TCDE2 °C or above for 80 seconds
- Machine runs for 10 consecutive minutes in Defrosting mode.

Defrosting Action

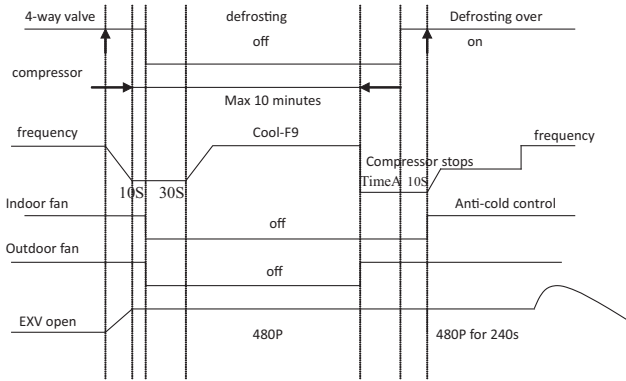

Fig. 34 – Defrosting Action

End Frosting Condition

If any one of following items is satisfied, defrosting stops and the machine enters the normal heating mode.

- 1 $T3 > \text{TempQuitDefrost_ADD } ^\circ\text{C}$;
- 2 The defrosting time achieves 10 min.
- 3 Turn to other modes or **OFF**.

Outdoor Fan Control

Cooling Mode

Under normal operating conditions, the system chooses the running fan speed according to the ambient temperature.

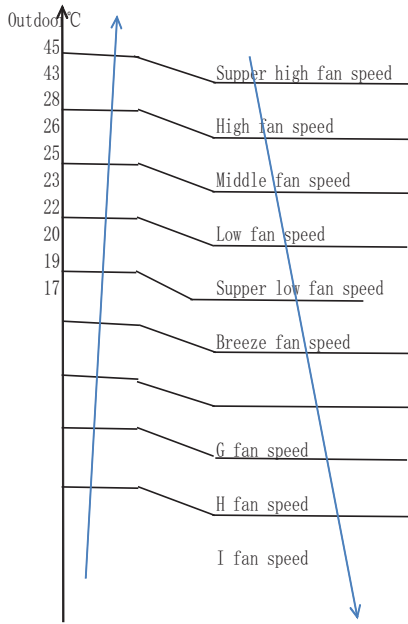

Fig. 35 – Cooling Mode

When low ambient cooling is in effect:

- The outdoor fan speed controls logic (low ambient cooling).

When $T4 < 59^\circ\text{F}$ (15°C) and $T3 < 86^\circ\text{F}$ (30°C), the unit enters into the low ambient cooling mode. The outdoor fan chooses a speed according to $T3$.

When $T3 \geq 100.4^\circ\text{F}$ (38°C) or when $T4 \geq 68^\circ\text{F}$ (20°C), the outdoor fan chooses a speed according to $T4$ again.

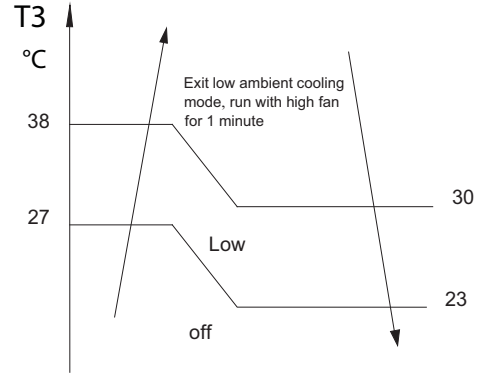

Fig. 36 – Cooling Mode

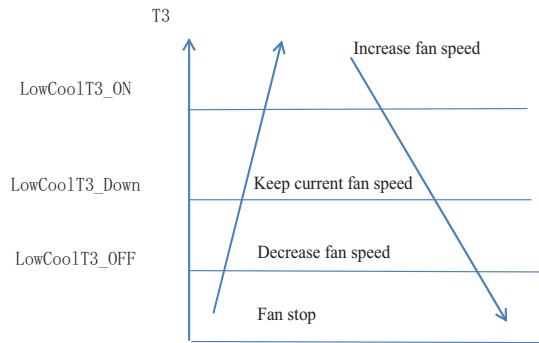

Fig. 37 – Cooling Mode

Heating Mode

Under normal operating conditions, the system chooses a running fan speed according to the ambient temperature.

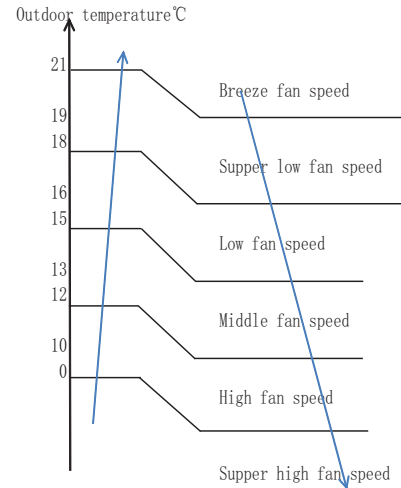

Fig. 38 – Heating Mode

Electronic Expansion Valve (EXV) Control

- 1 EXV is fully closed when power is turned on. The EXV will standby with the 350P open and then opens to the target angle after the compressor starts.
- 2 EXV will close with - 160P when the compressor stops. Then EXV will standby with the 350P open and then opens to the target angle after the compressor starts.
- 3 The action priority of the EXVs is A-B-C-D-E.
- 4 Compressor and the outdoor fan start operation only after the EXV is initialized.

Cooling mode

- 1 The initial open angle of EXV is dependent on indoor model size, adjustment range is 100-400p. When the unit starts to work for 3 minutes, the outdoor unit receives the indoor units' (of capacity demand) T2B information and calculates their average. After comparing each indoor's T2B with the average, the outdoor gives the following modification commands: if the $T2B > \text{average}$, the relevant valve needs more 16p open. If the $T2B = \text{average}$, the relevant valve's open range remains. If the $T2B < \text{average}$, the relevant valve needs more 16p close. This modification will be carried out every 2 minutes.

Heating mode

The initial open angle of EXV is 250P, dependent on indoor model size, adjustment range is 100-400p. After the unit works for 3 minutes, the outdoor unit receives the indoor units' (of capacity demand) T2 information and calculates the their average. After comparing each indoor units' T2 with the average, the outdoor unit gives the following modification commands.

If the $T2 < \text{average} + 2$, the relevant valve needs more 16p close. If $\text{average} + 2 \geq T2 \geq \text{average} - 2$, the relevant valve's open range remains. If the $T2 < \text{average} - 2$, the relevant valve needs more 16p open. This modification occurs every 2 minutes.

Four-way valve control

In the Heating mode, the four-way valve opens. In the Defrosting mode, the four-way valve operates in accordance to the Defrosting action. In other modes, the four-way valve is closed.

When the Heating mode changes to other modes, the four-way valve closes after the compressor is off for 2 minutes. Failure or protection (not including discharge temperature protection, high and low pressure protection), the four-way valve immediately shuts down.

TROUBLESHOOTING

This section provides the required flow charts to troubleshoot problems that may arise.

NOTE: Information required in the diagnoses can be found either on the wiring diagrams or in the appendix.

Required Tools:

The following tools are needed when diagnosing the units:

- Digital multimeter
- Screw drivers (Phillips and straight head)
- Needle-nose pliers
- Refrigeration gauges

Recommended Steps

- 1 Refer to the diagnostic hierarchy charts below and determine the problem at hand.
- 2 Go to the chart listed in the diagnostic hierarchy and follow the steps in the chart for the selected problem.

For the ease of service, the systems are equipped with diagnostic code display LED's on both the indoor and outdoor units. The outdoor diagnostic display is on the outdoor unit board and is limited to very few errors. The indoor diagnostic display is a combination of flashing LED's on the display panel on the front of the unit. If possible always check the diagnostic codes displayed on the indoor unit first.

The diagnostic codes for the indoor and outdoor units are listed in the appendix.

Problems may occur that are not covered by a diagnostic code, but are covered by the diagnostic flow charts. These problems are typical air conditioning mechanical or electrical issues that can be corrected using standard air conditioning repair techniques.

Diagnostic Guides

For problems requiring measurements at the control boards, note the following:

- 1 Always disconnect the main power.
- 2 When possible check the outdoor board first.
- 3 Start by removing the outdoor unit top cover.
- 4 Reconnect the main power
- 5 Probe the outdoor board inputs and outputs with a digital multi-meter referring to the wiring diagrams.
- 6 Connect the red probe to hot signal and the black probe to the ground or negative.
- 7 Note that some of the DC voltage signals are pulsating voltages for signal. this pulse should be rapidly moving at all times when there is a signal present.
- 8 If it is necessary to check the indoor unit board you must start by disconnecting the main power.
- 9 Next remove the front cover of the unit and then control box cover.
- 10 Carefully remove the indoor board from the control box, place it face up on a plastic surface (not metal).
- 11 Reconnect the main power and repeat steps 5, 6, and 7.
- 12 Disconnect main power before reinstalling board to avoid shock hazard and board damage.

Table 32—Outdoor Unit Error Display

OUTDOOR UNIT DISPLAY	LED STATUS	INDOOR UNIT DISPLAY
E0	Outdoor EEPROM malfunction	F4
E2	Communication malfunction between indoor and outdoor units	E1
E3	Communication malfunction between IPM board and outdoor main board	— —
E4	Open or short circuit of outdoor temperature sensor (T3、 T4、 T5、 T2B)	F2/F1/F3/F6
E5	Voltage protection	P1
E6	PFC module protection	— —
E8	Outdoor fan speed has been out of control (Only for DC fan motor models)	F5
E9	Wrong wiring connection of 24K indoor unit	— —
F1	No A Indoor unit coil outlet temp. sensor or connector of sensor is defective	— —
F2	No B Indoor unit coil outlet temp. sensor or connector of sensor is defective	— —
F3	No C Indoor unit coil outlet temp. sensor or connector of sensor is defective	— —
F4	No D Indoor unit coil outlet temp. sensor or connector of sensor is defective	— —
F5	No E Indoor unit coil outlet temp. sensor or connector of sensor is defective	— —
F6	No F Indoor unit coil outlet temp. sensor or connector of sensor is defective	— —
P0	Temperature protection of compressor top	P2
P1	High pressure protection	P2
P2	Low pressure protection	P2
P3	Current protection of compressor	F0
P4	Temperature protection of compressor discharge	— —
P5	High temperature protection of condenser	— —
P6	IPM module protection	P0

OUTDOOR UNIT DISPLAY

Outdoor Unit Point Function

A check switch is included on the outdoor PCB.

Push SW1 to check the unit's status while running. The digital display shows the following codes each time the SW1 is pushed.

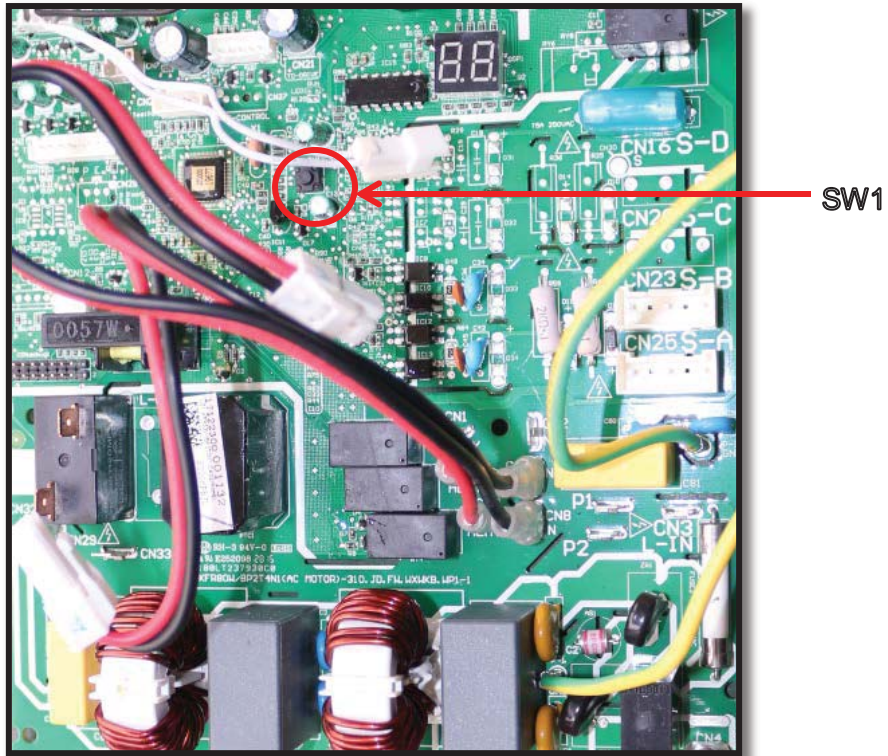

Fig. 39 – Outdoor PCB

OUTDOOR UNIT DISPLAY (CONT)

Table 33—Outdoor PCB

No. of Presses	Display	Remark		
0	Normal Display	Displays running frequency, running state, or malfunction code		
1	Quantity of indoor units with working connection	Actual Data		
		Display	Number of Indoor Units	
		1	1	
		2	2	
		3	3	
4	4			
2	Outdoor unit running mode code	Off: 0, Fan only: 1, Cooling: 2, Heating: 3, Forced cooling: 4, Forced defrost:A		
3	Indoor unit A capacity	The capacity unit is horse power. If the indoor unit is not connected, the digital display shows the following: “--” (9K:1HP;12K:1.2HP;18K:1.5HP)		
4	Indoor unit B capacity			
5	Indoor unit C capacity			
6	Indoor unit D capacity			
7	Indoor unit E capacity			
8	Indoor unit A capacity demand code	Norm code*HP (9K: 1HP;12K: 1.2HP;18K: 1.5HP)		
9	Indoor unit B capacity demand code			
10	Indoor unit C capacity demand code			
11	Indoor unit D capacity demand code			
12	Indoor unit E capacity demand code			
13	Outdoor unit amendatory capacity demand code			
14	The frequency corresponding to the total indoor units' amendatory capacity demand			
15	The frequency after the frequency limit			
16	The frequency sending to compressor control chip			
17	Indoor unit A evaporator outlet temperature (T _{2B} A)	If the temperature is lower than -9 °C, the digital display shows “-9.” If the temperature is higher than 70 °C, the digital display shows “70.” If the indoor unit is not connected, the digital display shows: “--”		
18	Indoor unit B evaporator outlet temperature (T _{2B} B)			
19	Indoor unit C evaporator outlet temperature (T _{2B} C)			
20	Indoor unit D evaporator outlet temperature (T _{2B} D)			
21	Indoor unit E evaporator outlet temperature (T _{2B} E)			
22	Indoor unit A room temperature (T ₁ A)	If the temperature is lower than 0 °C, the digital display shows “0.” If the temperature is higher than 50 °C, the digital display shows “50.” If the indoor unit is not connected, the digital display shows: “--”		
23	Indoor unit B room temperature (T ₁ B)			
24	Indoor unit C room temperature (T ₁ C)			
25	Indoor unit D room temperature (T ₁ D)			
26	Indoor unit E room temperature (T ₁ E)			
27	Indoor unit A evaporator temperature (T ₂ A)	If the temperature is lower than -9 °C, the digital display shows “-9.” If the temperature is higher than 70 °C, the digital display shows “70.” If the indoor unit is not connected, the digital display shows: “--”		
28	Indoor unit B evaporator temperature (T ₂ B)			
29	Indoor unit C evaporator temperature (T ₂ C)			
30	Indoor unit D evaporator temperature (T ₂ D)			
31	Indoor unit E evaporator temperature (T ₂ E)			
32	Condenser pipe temperature (T ₃)	The display value is between 30-129 °C. If the temperature is lower than 30 °C, the digital display shows “30.” If the temperature is higher than 99 °C, the digital display shows single and double digits. For example, if the digital display shows “0.5”, the compressor discharge temperature is 105 °C.		
33	Outdoor ambient temperature (T ₄)			
34	Compressor discharge temperature (TP)			
35	AD value of current	The display value is a hex number. For example, the digital display tube shows “Cd”, it means AD value is 205.		
36	AD value of voltage			
37	EXV open angle for A indoor unit	Actual data/4. If the value is higher than 99, the digital display shows single and double digits. For example, if the digital display shows “2.0”, the EXV open angle is 120×4=480p.		
38	EXV open angle for B indoor unit			
39	EXV open angle for C indoor unit			
40	EXV open angle for D indoor unit			
41	EXV open angle for E indoor unit			
42	Frequency limit symbol	Bit7	Frequency limit caused by IGBT radiator	The display value is a hexadecimal number. For example, the digital display show 2A, then Bit5=1, Bit3=1, and Bit1=1. This means that a frequency limit may be caused by T4, T3, or the current.
		Bit6	Frequency limit caused by PFC	
		Bit5	Frequency limit caused by T4.	
		Bit4	Frequency limit caused by T2.	
		Bit3	Frequency limit caused by T3.	
		Bit2	Frequency limit caused by T5.	
		Bit1	Frequency limit caused by current	
Bit0	Frequency limit caused by voltage			
43	Average value of T2	(Sum T2 value of all indoor units)/(number of indoor units in good connection)		
44	Outdoor unit fan motor state	Off: 0, High speed:1, Med speed: 2, Low speed: 3, Breeze:4, Super breeze: 5		
45	The last error or protection code	00 means No Malfunction and Protection		
46	F indoor unit capacity			
47	F indoor unit capacity demand code			
48	F indoor unit evaporator outlet temperature (T _{2B} F)			
49	F indoor unit room temperature (T ₁ F)			
50	F indoor unit evaporator temperature (T ₂ F)			
51	EXV open angle for F indoor unit			

DIAGNOSIS AND SOLUTION

Indoor fan speed has been out of control

Table 34—Diagnosis and Solution

Malfunction decision conditions	When the indoor fan speed remains low (300RPM) for certain period of time, the unit stops and the LED displays the failure.
Supposed causes	<ul style="list-style-type: none"> • Wiring mistake • Fan assembly faulty • Fan motor faulty • PCB faulty

Troubleshooting

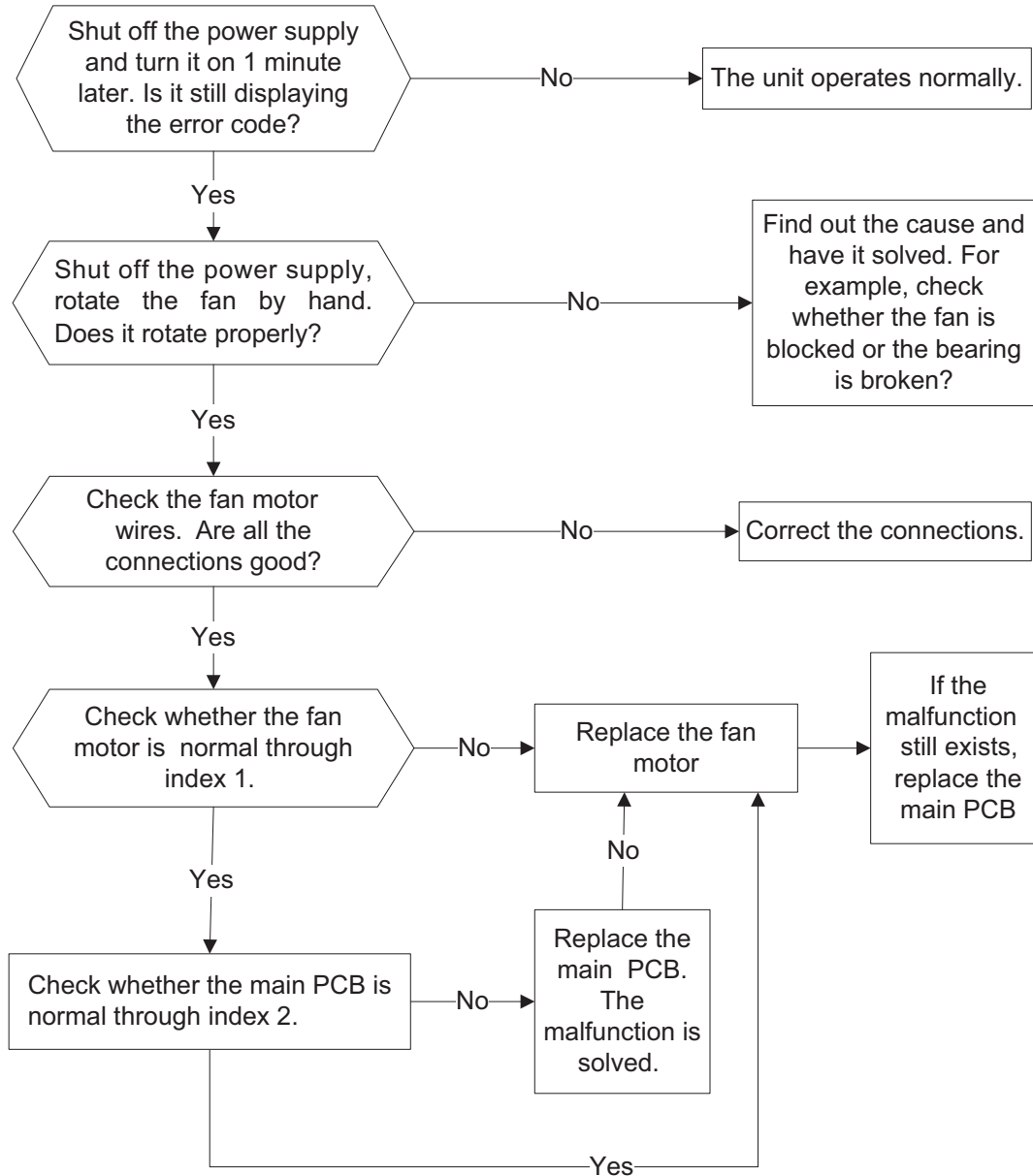

DIAGNOSIS AND SOLUTION (CONT)

Indoor units mode conflict

Table 35—Diagnosis and Solution

Error Code	P5 (old model) or – (new model)
Malfunction decision conditions	The indoor units cannot operate the Cooling mode and Heating mode at the same time. The Heating mode has the priority.
Supposed causes	<ul style="list-style-type: none"> • Suppose indoor unit A is operating under the Cooling or Fan mode, and indoor unit B is set to the Heating mode, then unit A turns off and unit B operates in the Heating mode. • Suppose indoor unit A is operating in the Heating mode, and indoor unit B is set to the Cooling or Fan mode, then unit B enters the Standby mode and unit A will not change its operation.

Table 36—Mode Conflict

	COOLING MODE	HEATING MODE	FAN	OFF
Cooling Mode	No	Yes	No	No
Heating Mode	Yes	No	Yes	No
Fan	No	Yes	No	No
Off	No	No	No	No

- **No:** No mode conflict
- **Yes:** Mode conflict

DIAGNOSIS AND SOLUTION (CONT)

EO EEPROM parameter error

Table 37—Diagnosis and Solution

Error Code	E0/F4
Malfunction decision conditions	Indoor or outdoor PCB main chip does not receive feedback from EEPROM chip
Supposed causes	<ul style="list-style-type: none">• Installation mistake• PCB faulty

Troubleshooting:

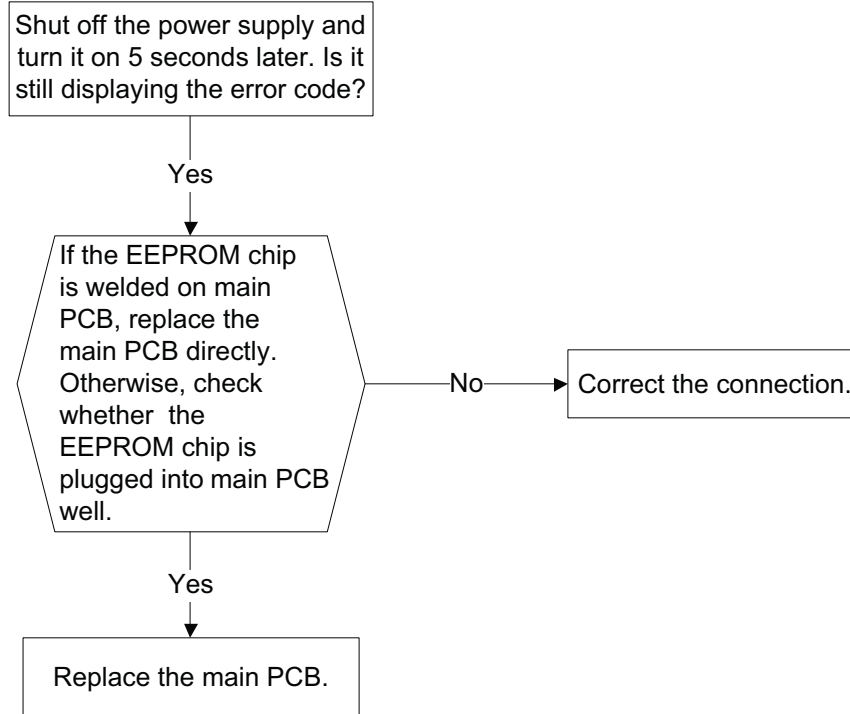

EEPROM: A read-only memory whose contents can be erased and reprogrammed using a pulsed voltage.

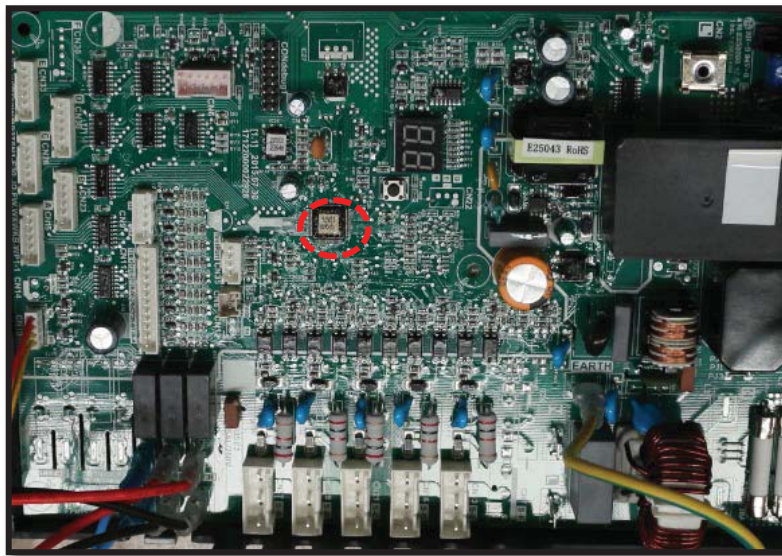

Fig. 40 – EEPROM Chip

DIAGNOSIS AND SOLUTION (CONT)

E2 error (Communication malfunction between the indoor and outdoor units)

Table 38—Diagnosis and Solution

Error Code	E2/E1
Malfunction decision conditions	Indoor unit does not receive feedback from the outdoor unit during 120 seconds or the outdoor unit does not receive feedback from any indoor unit during 180 seconds.
Supposed causes	<ul style="list-style-type: none"> • Wiring mistake • Indoor or outdoor PCB faulty

Troubleshooting

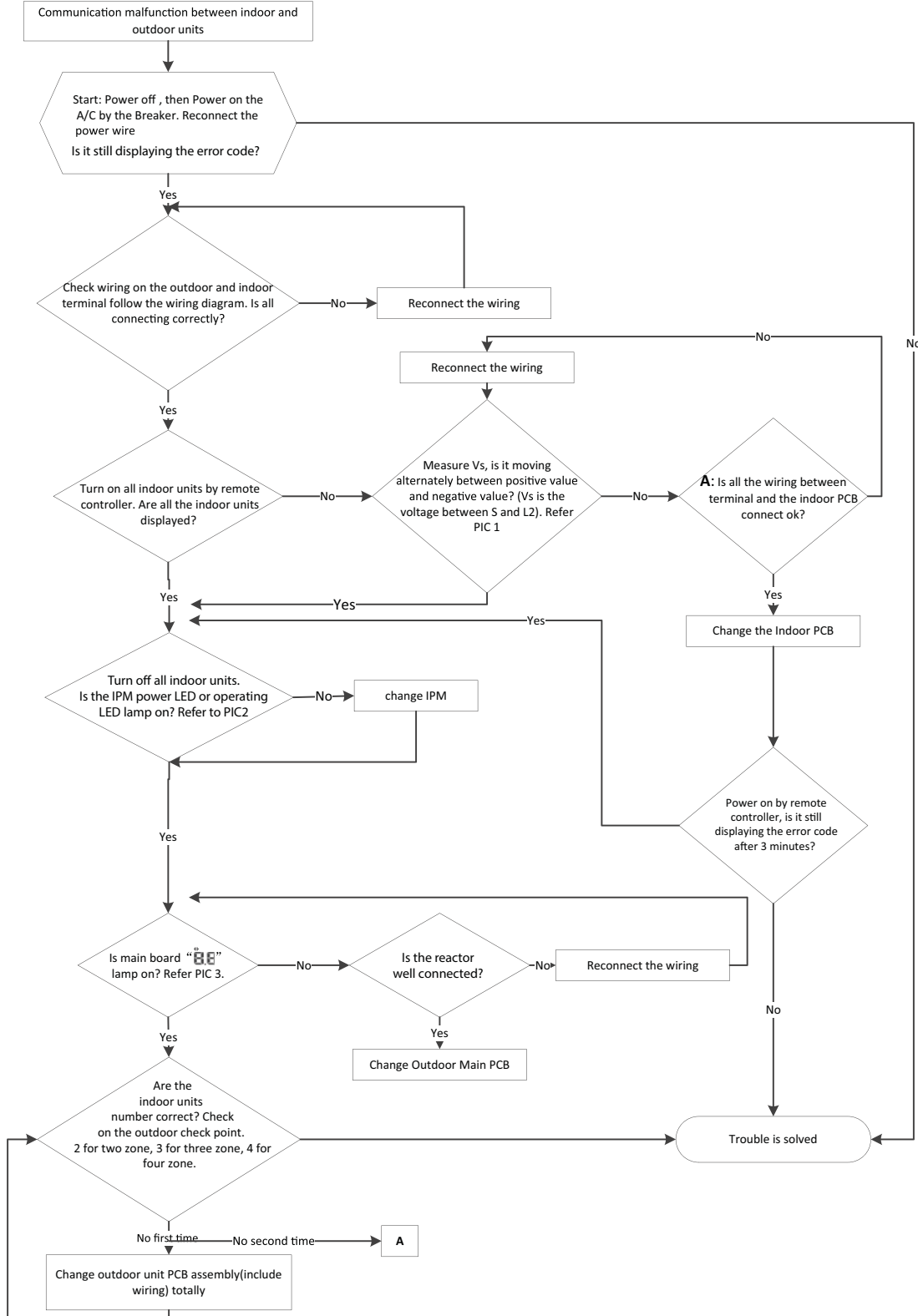

DIAGNOSIS AND SOLUTION (CONT)

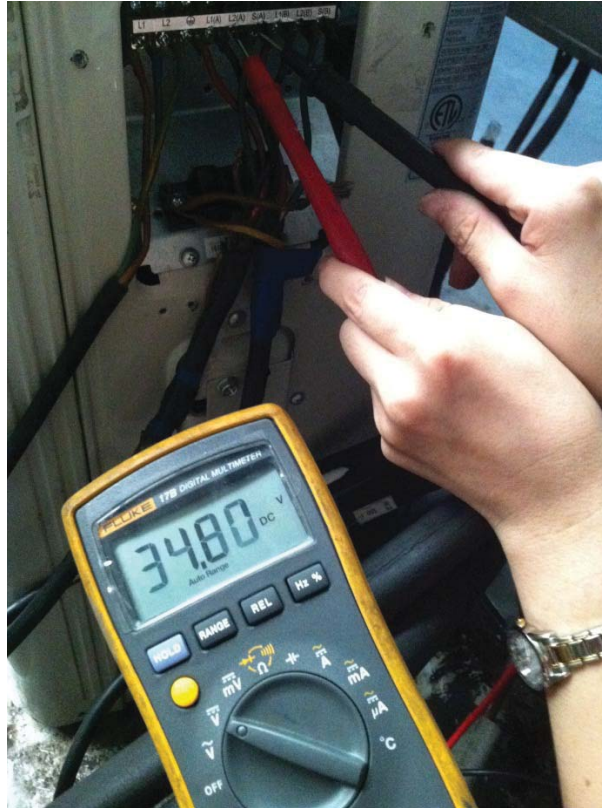

Fig. 41 – Test the DC voltage

Use a multimeter to test the DC voltage between the L2 port and S port of the outdoor unit. The red pin of the multimeter connects with the L2 port while the black pin is for the S port. When AC is normal running, the voltage will move alternately between positive value and negative value.

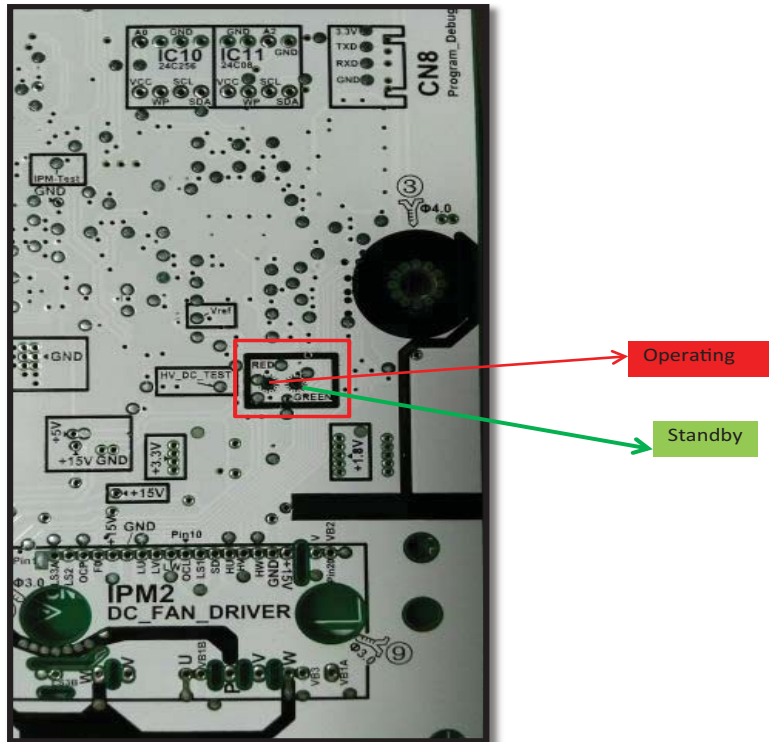
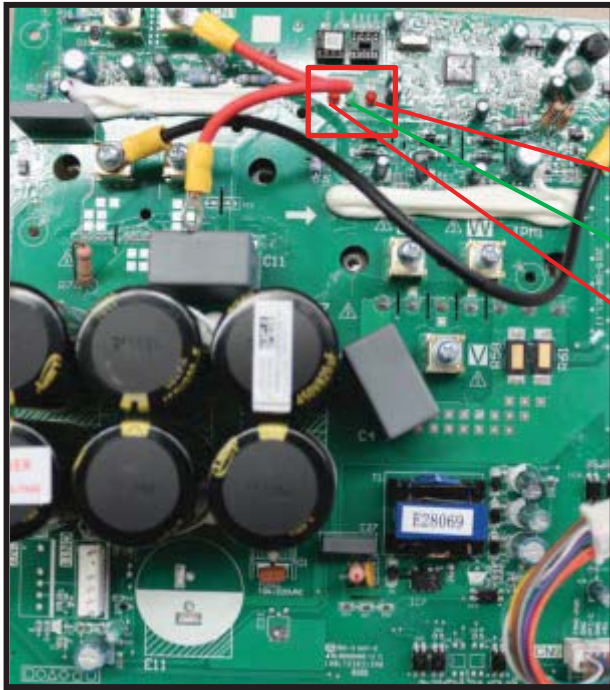

Fig. 42 – IPM (For dual/tri-zone)

DIAGNOSIS AND SOLUTION (CONT)



Pic 2: IPM (For four or five zone)

Operating

Standby

Power

Fig. 43 – IPM for four or five zone



Fig. 44 – Main Board

The main board LED when power on and unit standby.

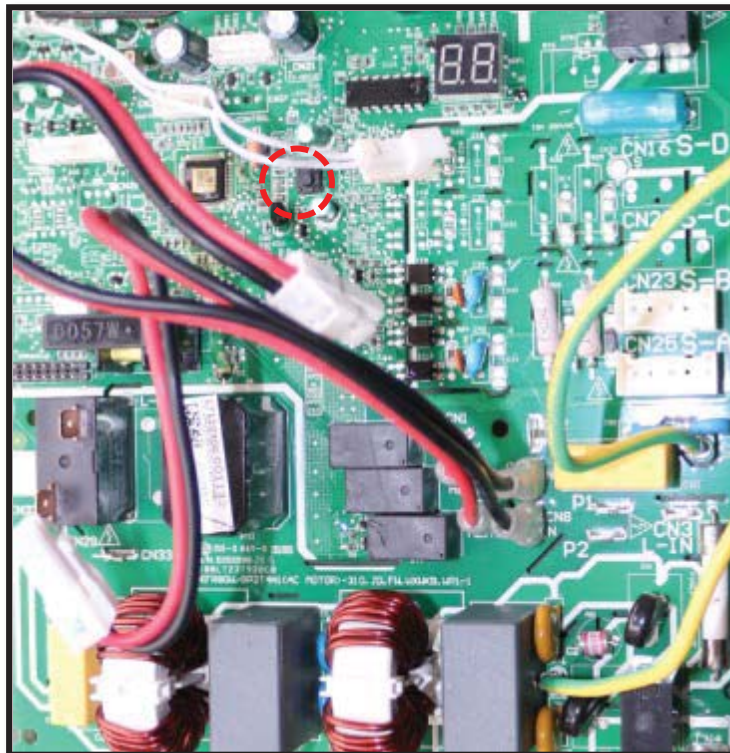

Fig. 45 – Main Board

Check the point button. Press one (1) time to determine how many indoor units are connected.

DIAGNOSIS AND SOLUTION (CONT)

Zero Crossing Detection Error Diagnosis and Solution

Table 39—Diagnosis and Solution

Error Code	E2
Malfunction decision conditions	When PCB does not receive zero crossing signal feedback for 4 minutes or the zero crossing signal interval is abnormal
Supposed causes	<ul style="list-style-type: none">• Connection mistake• PCB faulty

Troubleshooting:

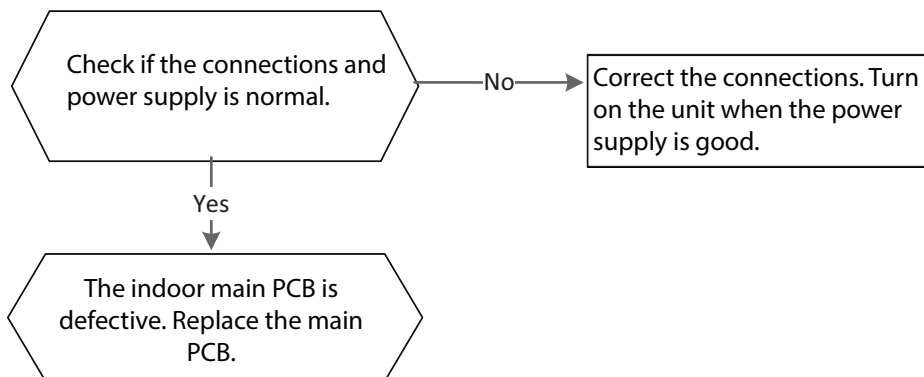

DIAGNOSIS AND SOLUTION (CONT)

E3 (Communication malfunction between IPM board and outdoor main board) error diagnosis

Table 40—Diagnosis and Solution

Error Code	E3
Malfunction decision conditions	PCB main chip does not receive feedback from IPM module during 60 seconds.
Supposed causes	<ul style="list-style-type: none"> • Wiring mistake • PCB faulty

Troubleshooting

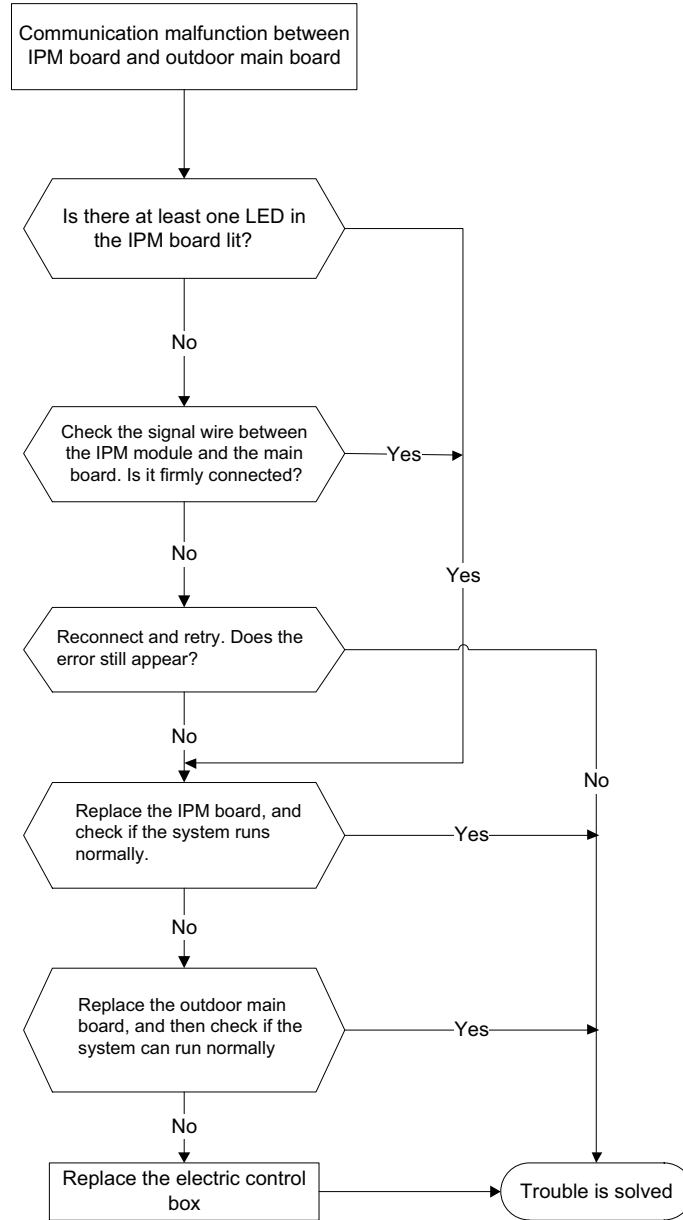

DIAGNOSIS AND SOLUTION (CONT)

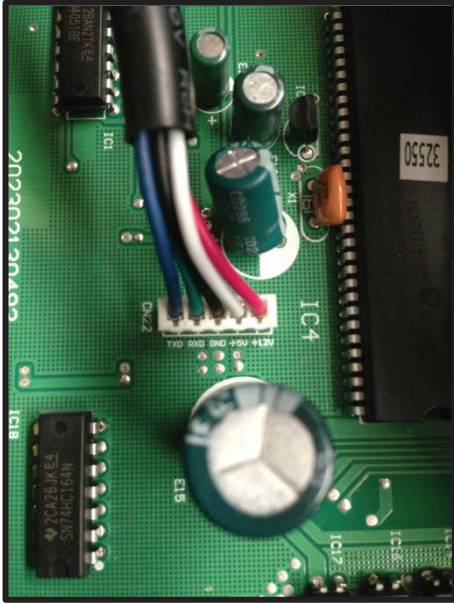

Remark:

Use a multimeter to test the DC voltage between black pin and white pin of signal wire. The normal value should be around 5V.

Use a multimeter to test the DC voltage between black pin and red pin of signal wire. The normal value should be around 12V.

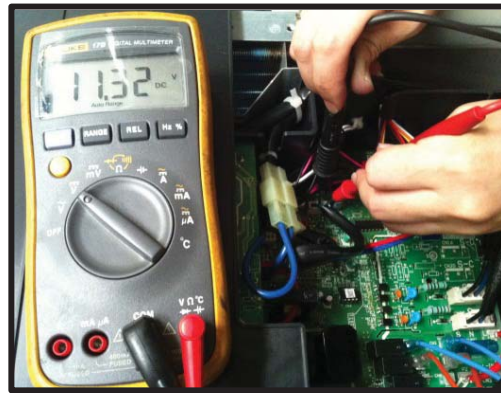
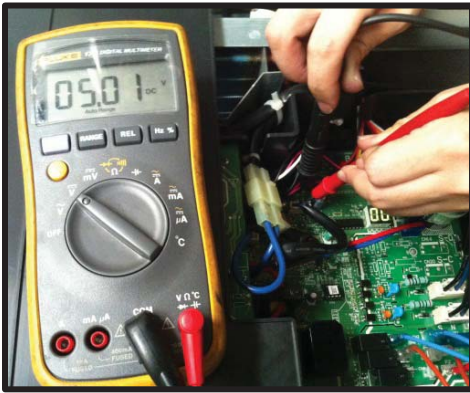

Fig. 46 – Test the DC Voltage

DIAGNOSIS AND SOLUTION (CONT)

E4 (open or short circuit of outdoor temperature sensor) diagnosis and solution F1/F2/F3/F4/F5 (open or short circuit of indoor coil temperature sensor) diagnosis and solution

Table 41—Diagnosis and Solution

Error Code	E4/F1/F2/F3/F4/F5/F6
Malfunction decision conditions	If the sampling voltage is lower than 0.06V or higher than 4.94V, the LED displays the failure.
Supposed causes	<ul style="list-style-type: none"> • Wiring mistake • Sensor faulty • PCB faulty

Troubleshooting

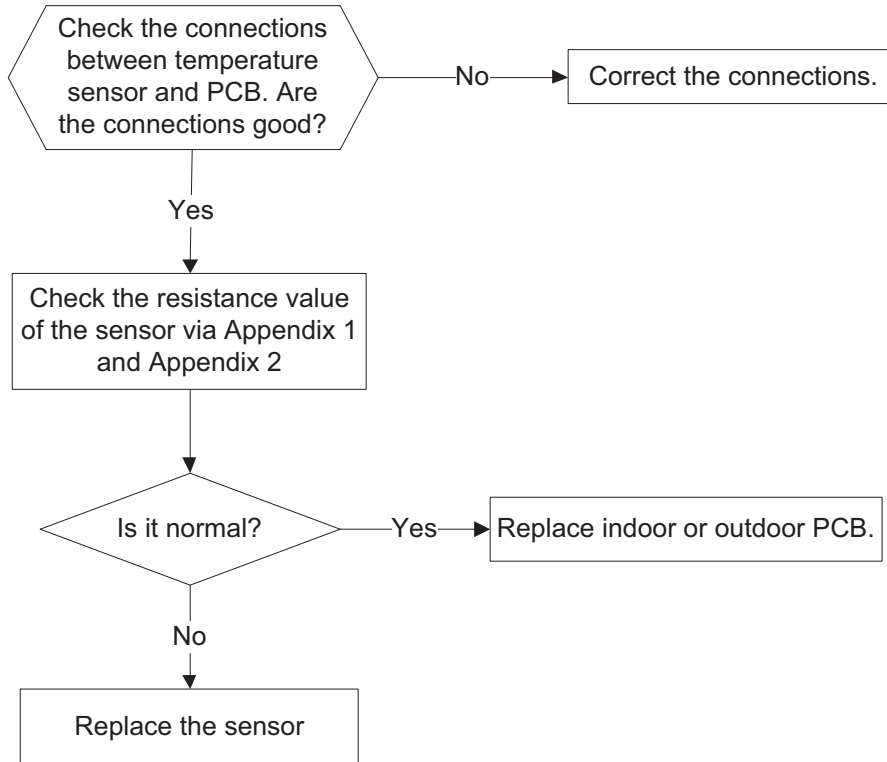

Fig. 47 – Check the Sensor Value

DIAGNOSIS AND SOLUTION (CONT)

E5 (Voltage protection) error

Table 42—Diagnosis and Solution

Error Code	E5
Malfunction decision conditions	An abnormal voltage rise or drop is detected by checking the specified voltage detection circuit.
Supposed causes	<ul style="list-style-type: none"> • Power supply problems • System leakage or block • PCB faulty

Troubleshooting

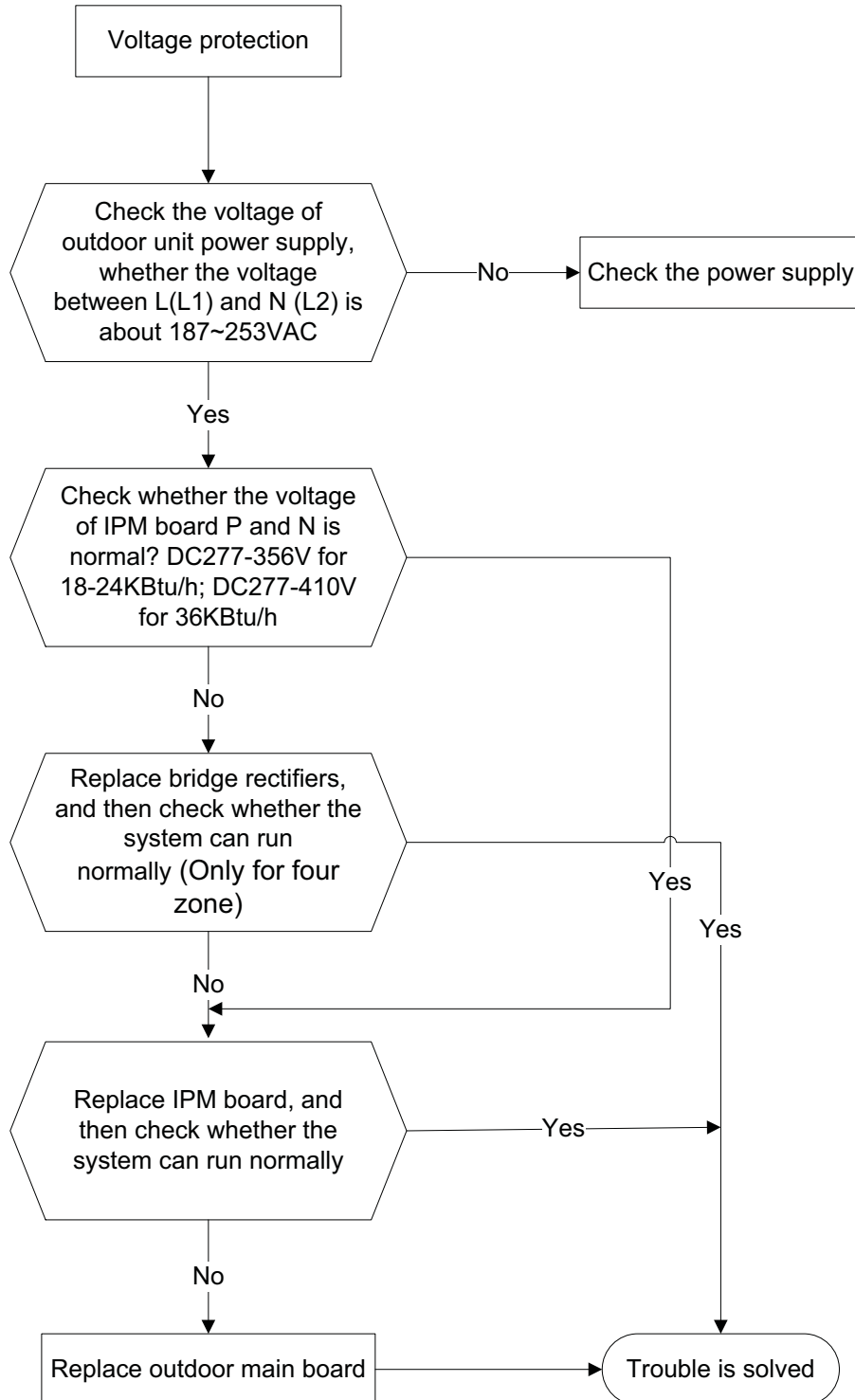

DIAGNOSIS AND SOLUTION (CONT)

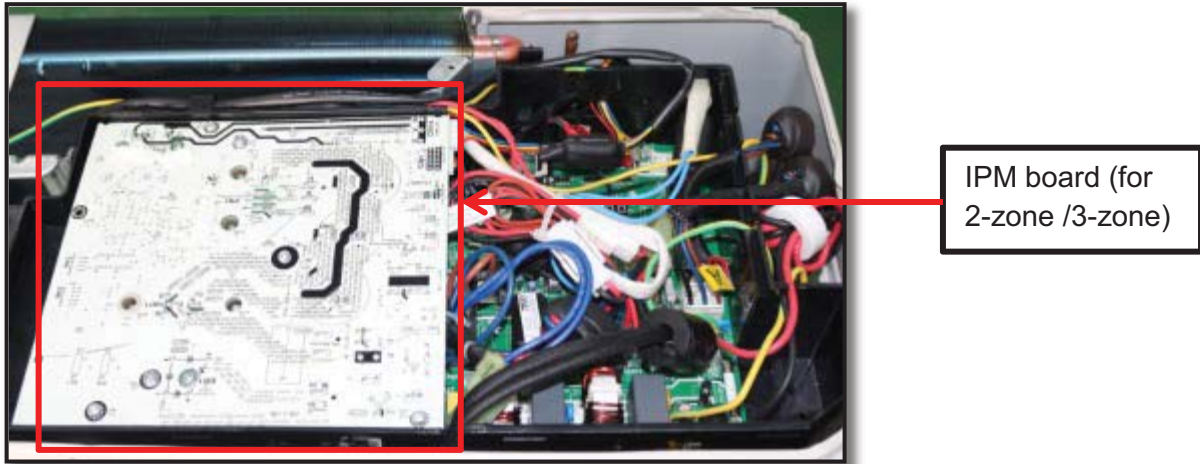

IPM board (for 2-zone /3-zone)

Fig. 48 – IPM Board (for 2–zone/3–zone)

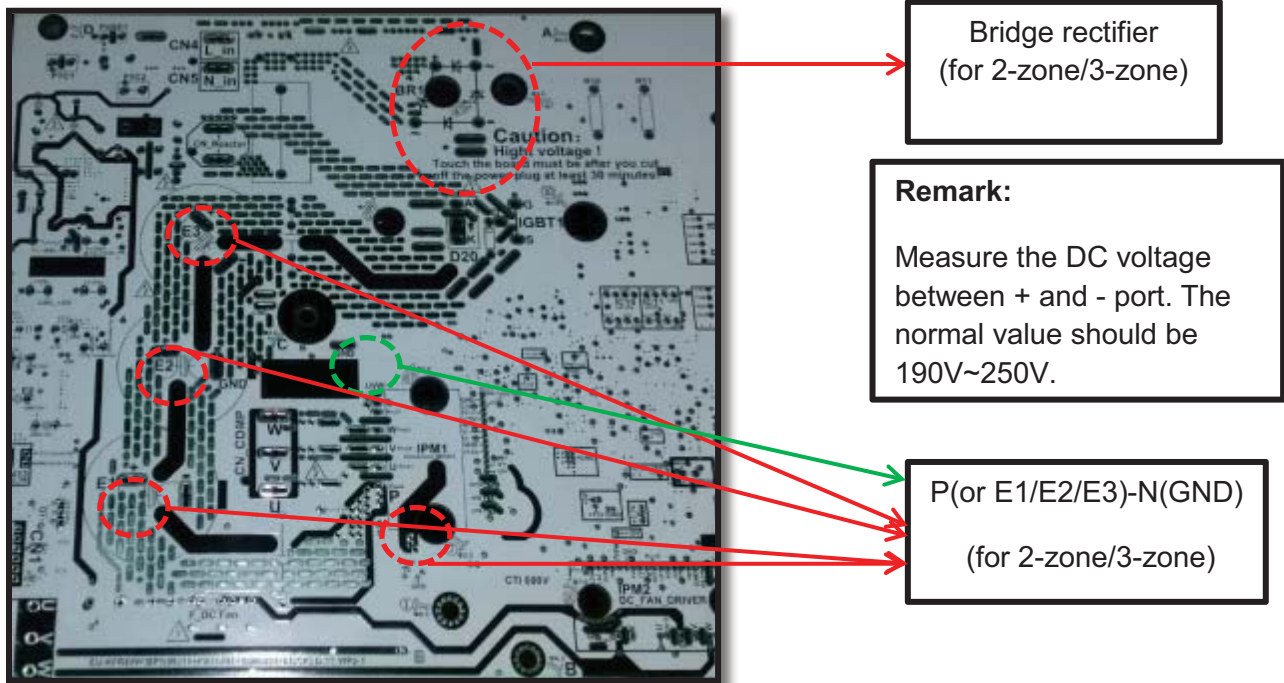

Bridge rectifier (for 2-zone/3-zone)

Remark:
Measure the DC voltage between + and - port. The normal value should be 190V~250V.

P(or E1/E2/E3)-N(GND) (for 2-zone/3-zone)

Fig. 49 – Bridge rectifier (for 2–zone/3–zone)

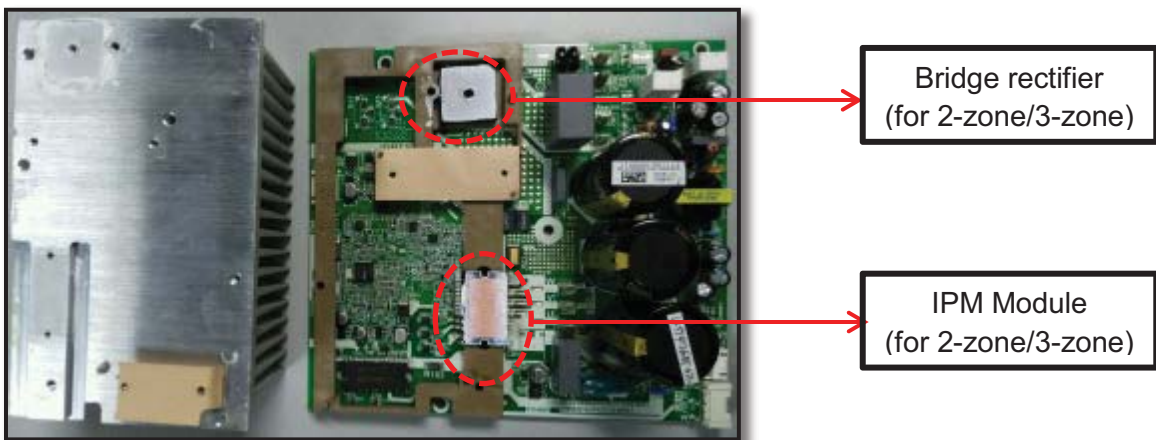

Bridge rectifier (for 2-zone/3-zone)

IPM Module (for 2-zone/3-zone)

Fig. 50 – Bridge Rectifier (for 2–zone/3–zone) and IPM Module (for 2–zone/3–zone)

DIAGNOSIS AND SOLUTION (CONT)

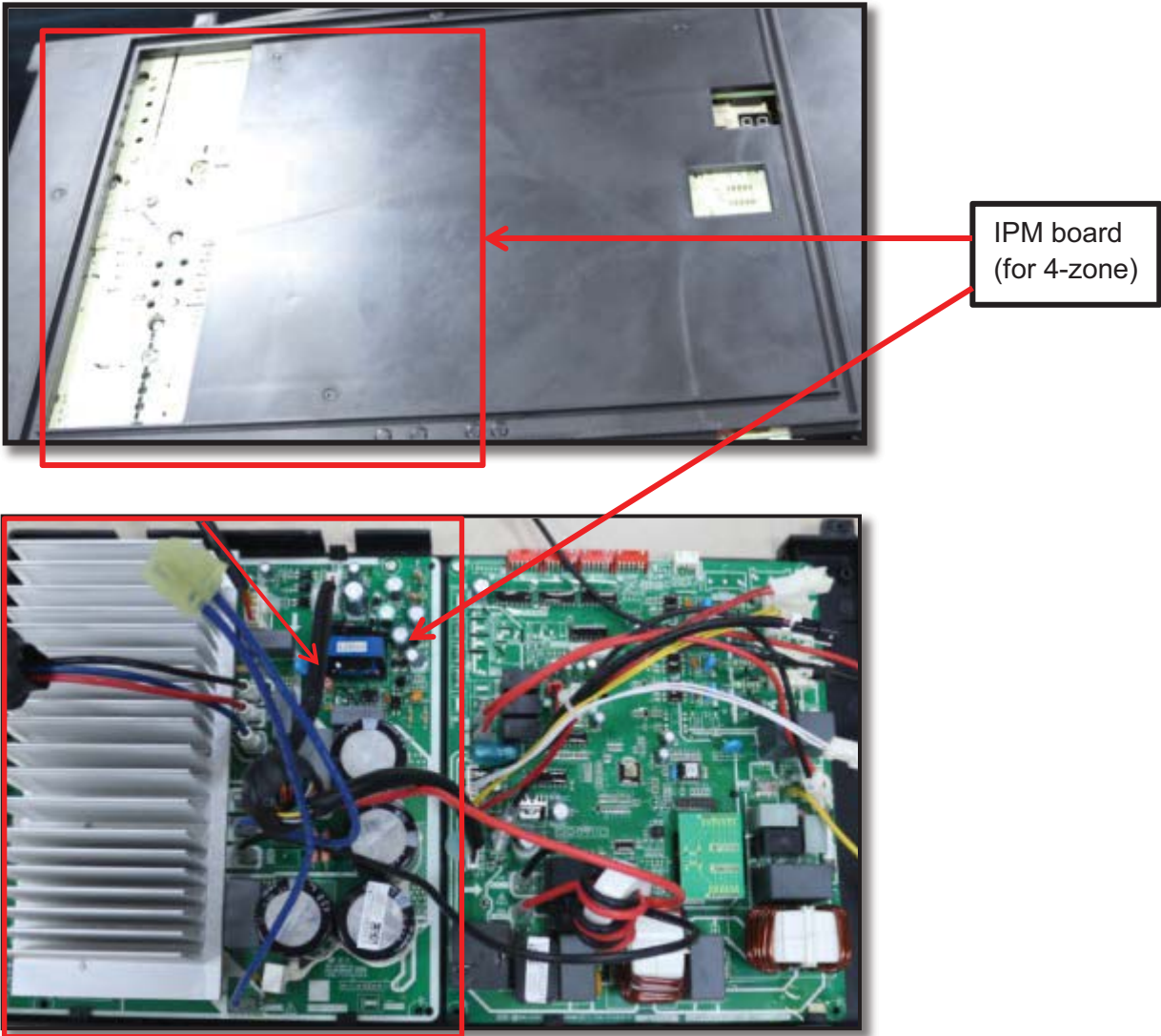

Fig. 51 – IPM Board (for 4–zone)

DIAGNOSIS AND SOLUTION (CONT)

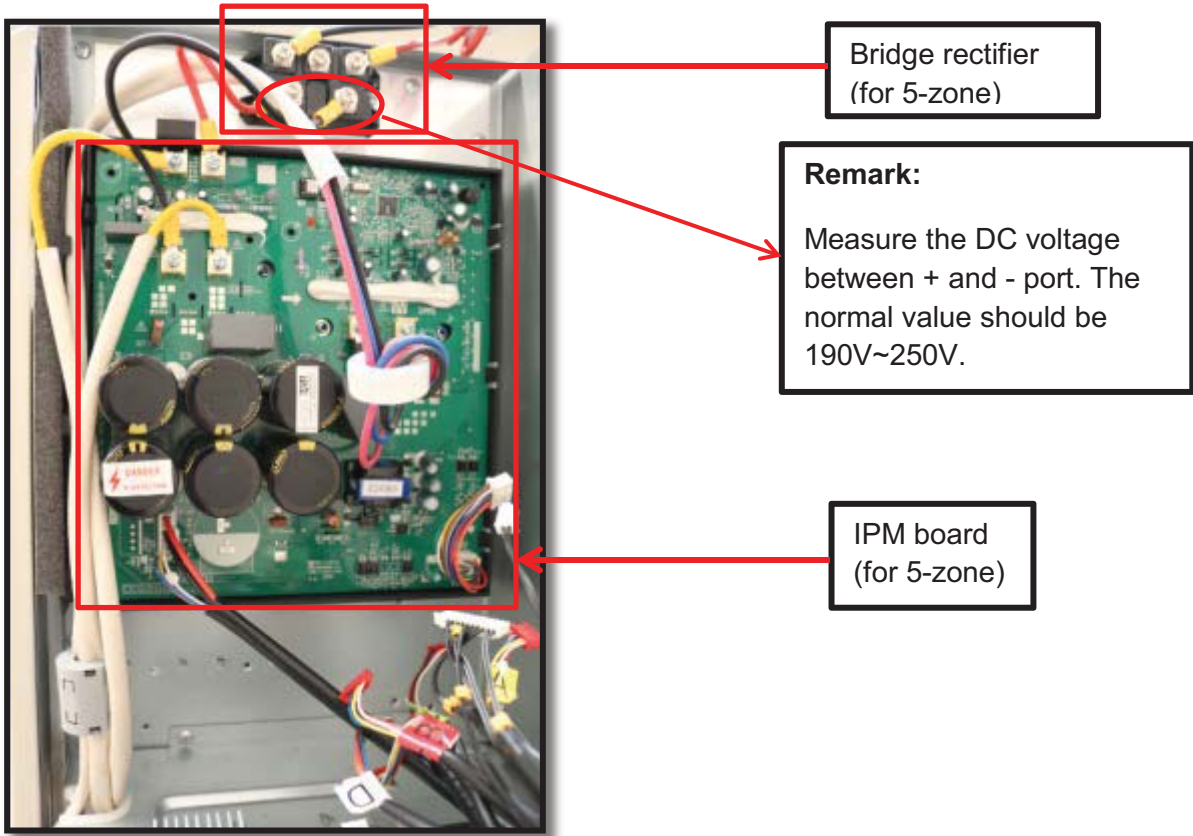

Fig. 52 – Bridge Rectifier (for 5-zone)

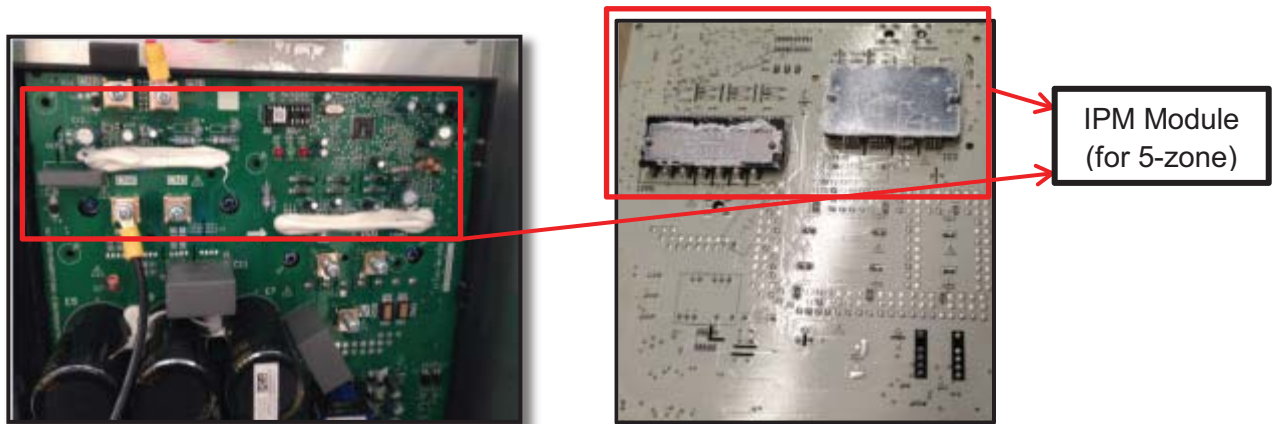

Fig. 53 – IPM Module (for 5 - zone)

DIAGNOSIS AND SOLUTION (CONT)

E6 (PFC module protection) error diagnosis and solution

Table 43—Diagnosis and Solution

Error Code	E6
Malfunction decision conditions	When the voltage signal that PFC sends to main control board is abnormal, the display LED displays "E6" and the AC turns off.
Supposed causes	<ul style="list-style-type: none"> • Wiring mistake • Outdoor PCB faulty • Inductance of PFC module faulty • PFC module malfunction

Troubleshooting

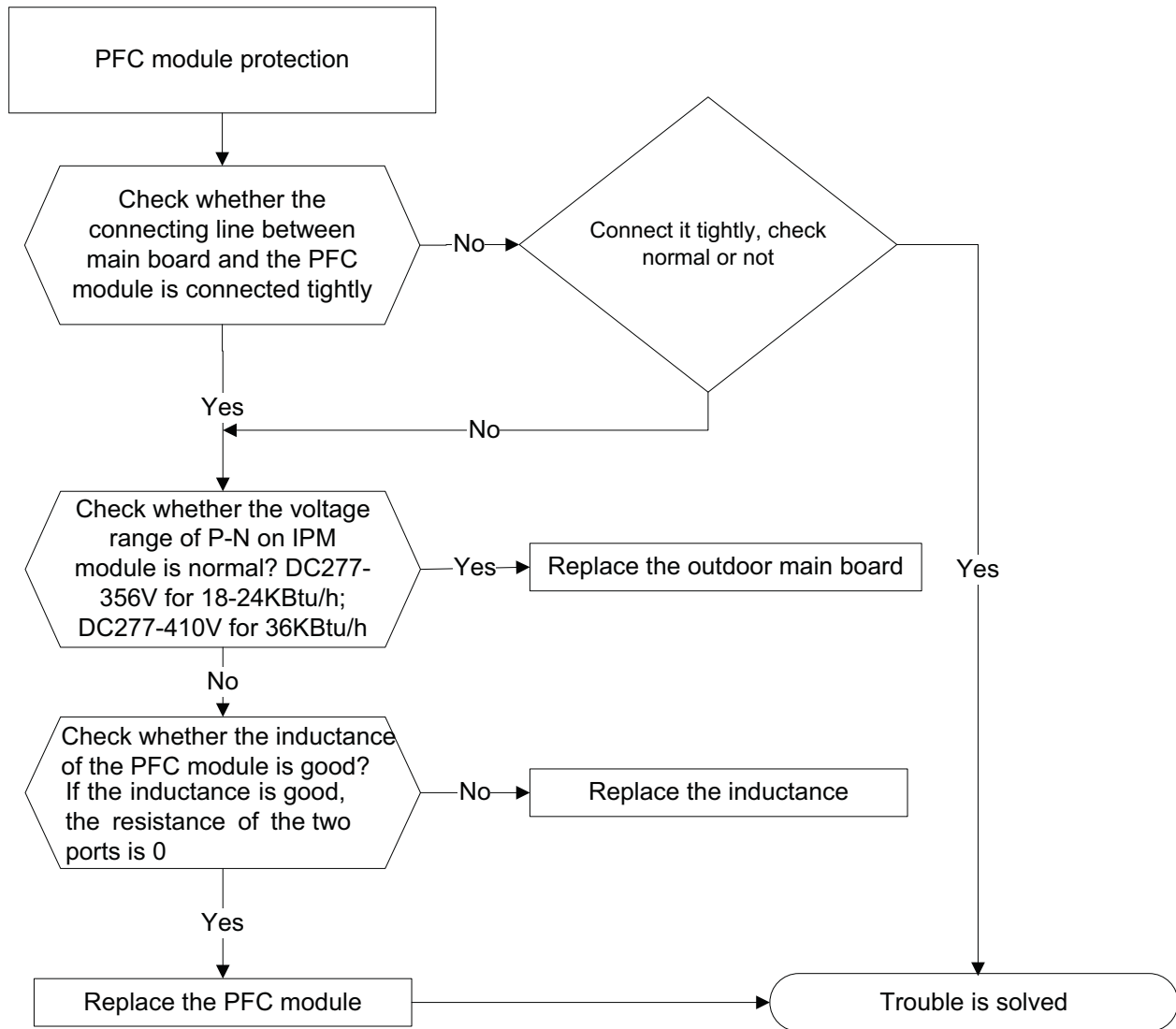

DIAGNOSIS AND SOLUTION (CONT)

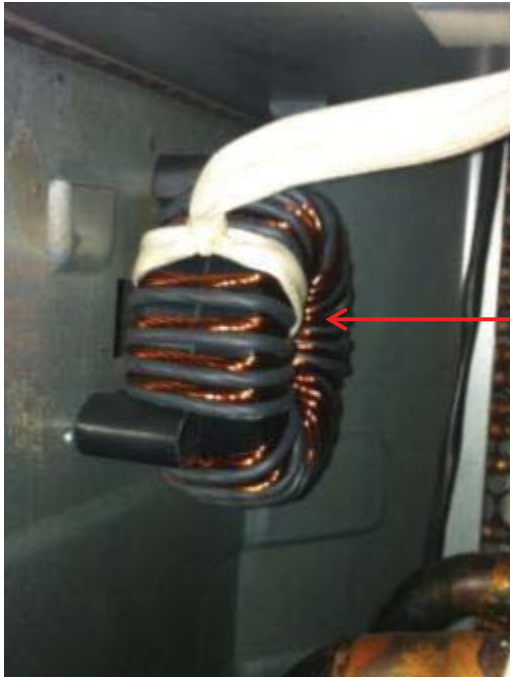

Inductance

Fig. 54 – Inductance

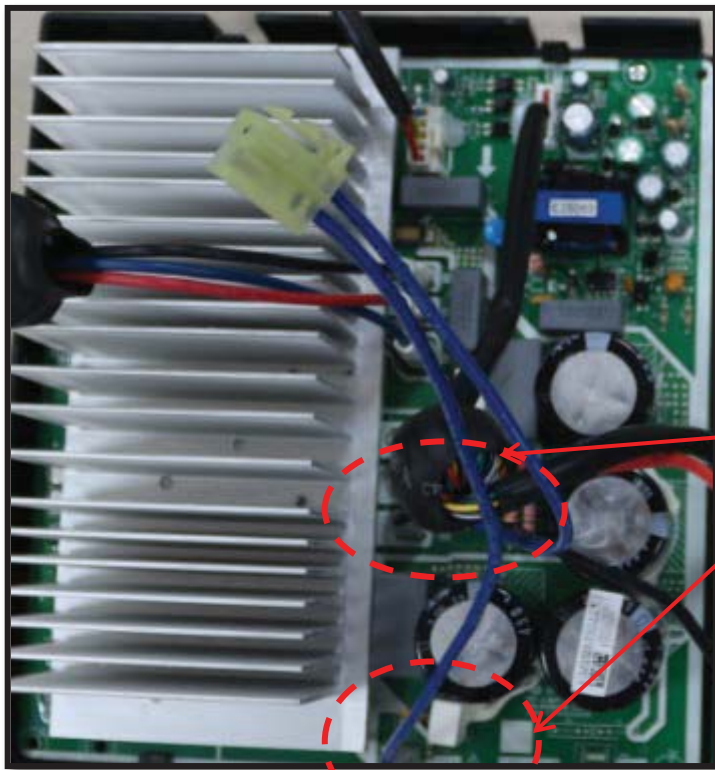

Two ports of the inductance

Fig. 55 – Inductance

DIAGNOSIS AND SOLUTION (CONT)

E8 – Outdoor fan speed has been out of control

Table 44—Diagnosis and Solution

Error Code	E8
Malfunction decision conditions	When outdoor fan speed keeps too low (300RPM) or too high (2400RPM) for certain time, the unit stops and the LED displays the failure.
Supposed causes	<ul style="list-style-type: none"> • Wiring mistake • Fan ass'y faulty • Fan motor faulty • PCB faulty

Troubleshooting

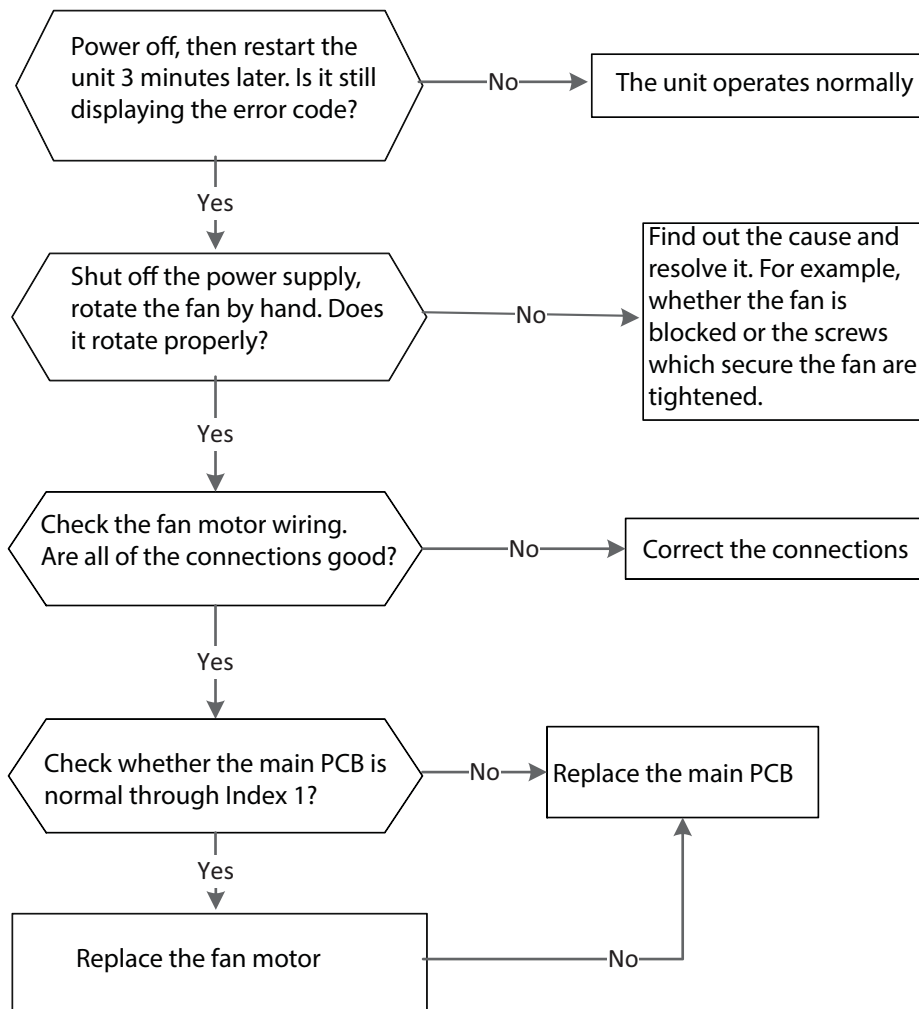

DIAGNOSIS AND SOLUTION (CONT)

Index 1:

DC fan motor (control chip is inside fan motor)

Power on and when the unit is in standby, measure the voltage of pin1–pin3, pin4–pin3 in fan motor connector. If the value of the voltage is not in the range showing in below table, the PCB must have problems and need to be replaced.

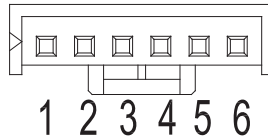
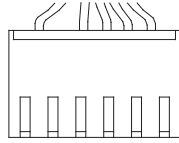

Fig. 56 – DC Fan Motor

Table 45—DC Motor Voltage Input and Output

NO.	Color	Signal	Voltage
1	Red	Vs/Vm	200~380V
2	---	---	---
3	Black	GND	0V
4	White	Vcc	13.5~16.5V
5	Yellow	Vsp	0~6.5V
6	Blue	FG	13.5~16.5V

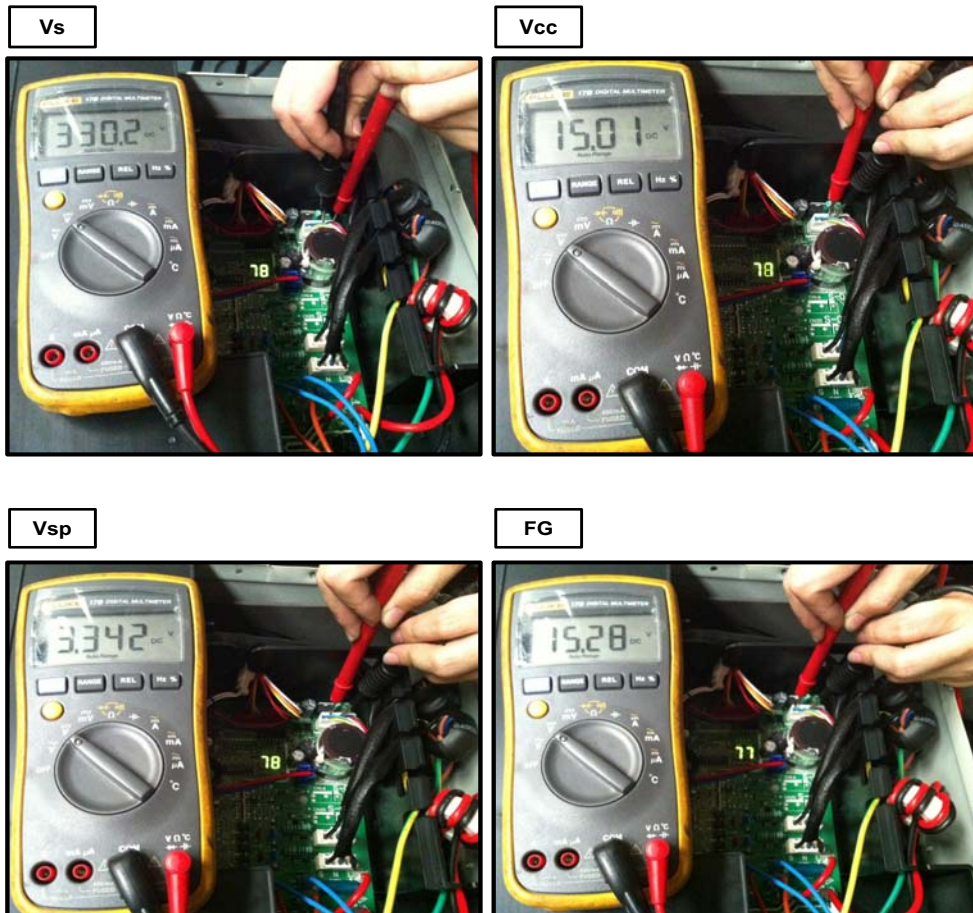

Fig. 57 – Test the voltage

DIAGNOSIS AND SOLUTION (CONT)

P0 (Temperature protection of compressor top) error

Table 46—Diagnosis and Solution

Error Code	P0
Malfunction decision conditions	If the sampling voltage is not 5V, the LED displays the failure.
Supposed causes	<ul style="list-style-type: none"> • Wiring mistake • Over load protector faulty • System block • Outdoor PCB faulty

Troubleshooting

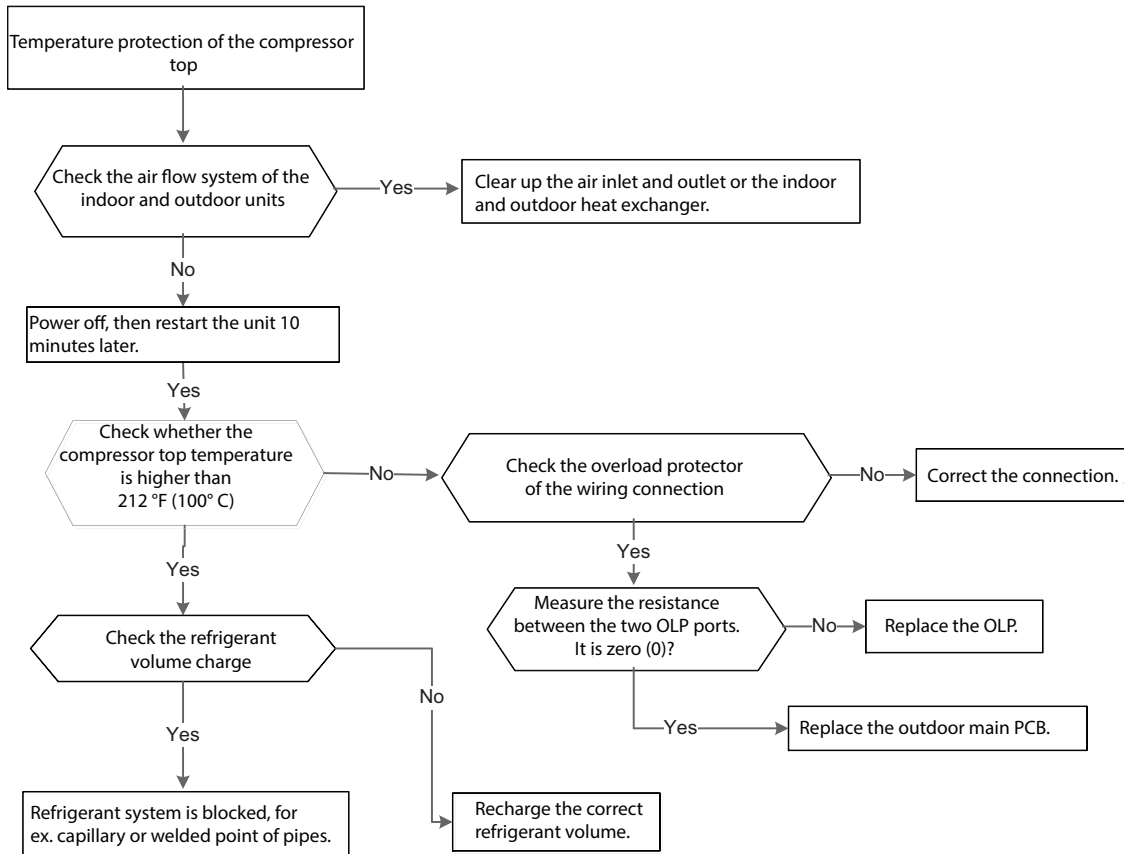

DIAGNOSIS AND SOLUTION (CONT)

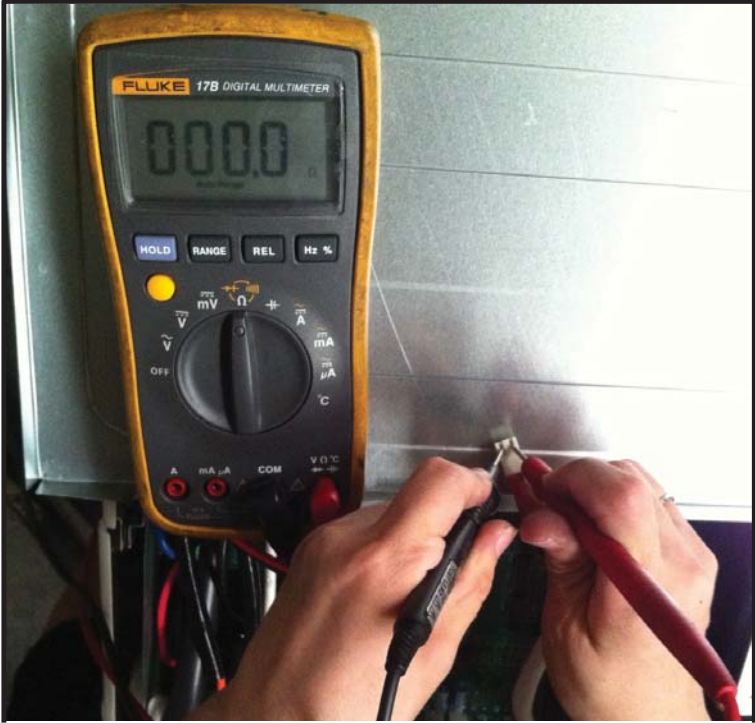
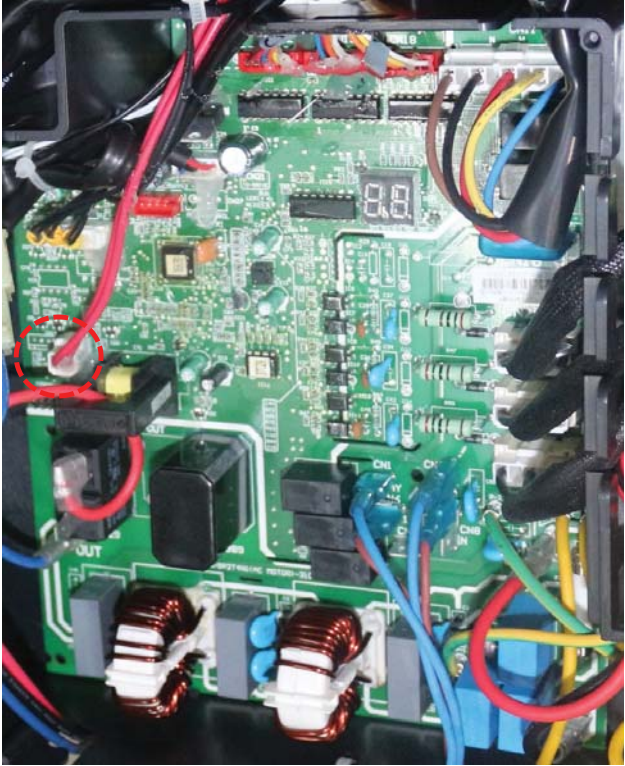

Fig. 58 – Test the voltage

DIAGNOSIS AND SOLUTION (CONT)

P1(High pressure protection) error

Table 47—Diagnosis and Solution

Error Code	P1
Malfunction decision conditions	If the sampling voltage is not 5V, the LED displays the failure.
Supposed causes	<ul style="list-style-type: none"> • Wiring mistake • Over load protector faulty • System block • Outdoor PCB faulty

Troubleshooting

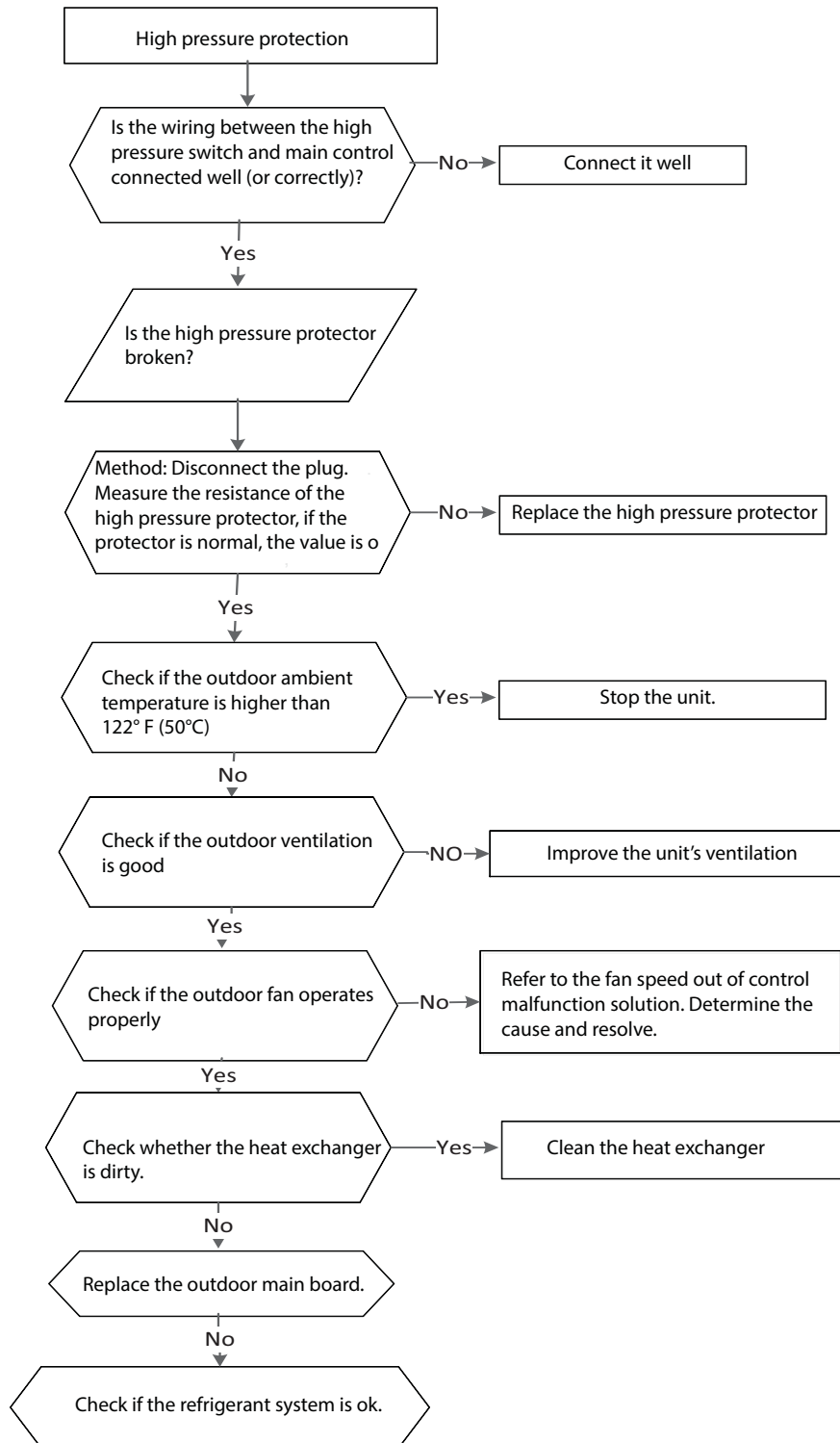

DIAGNOSIS AND SOLUTION (CONT)

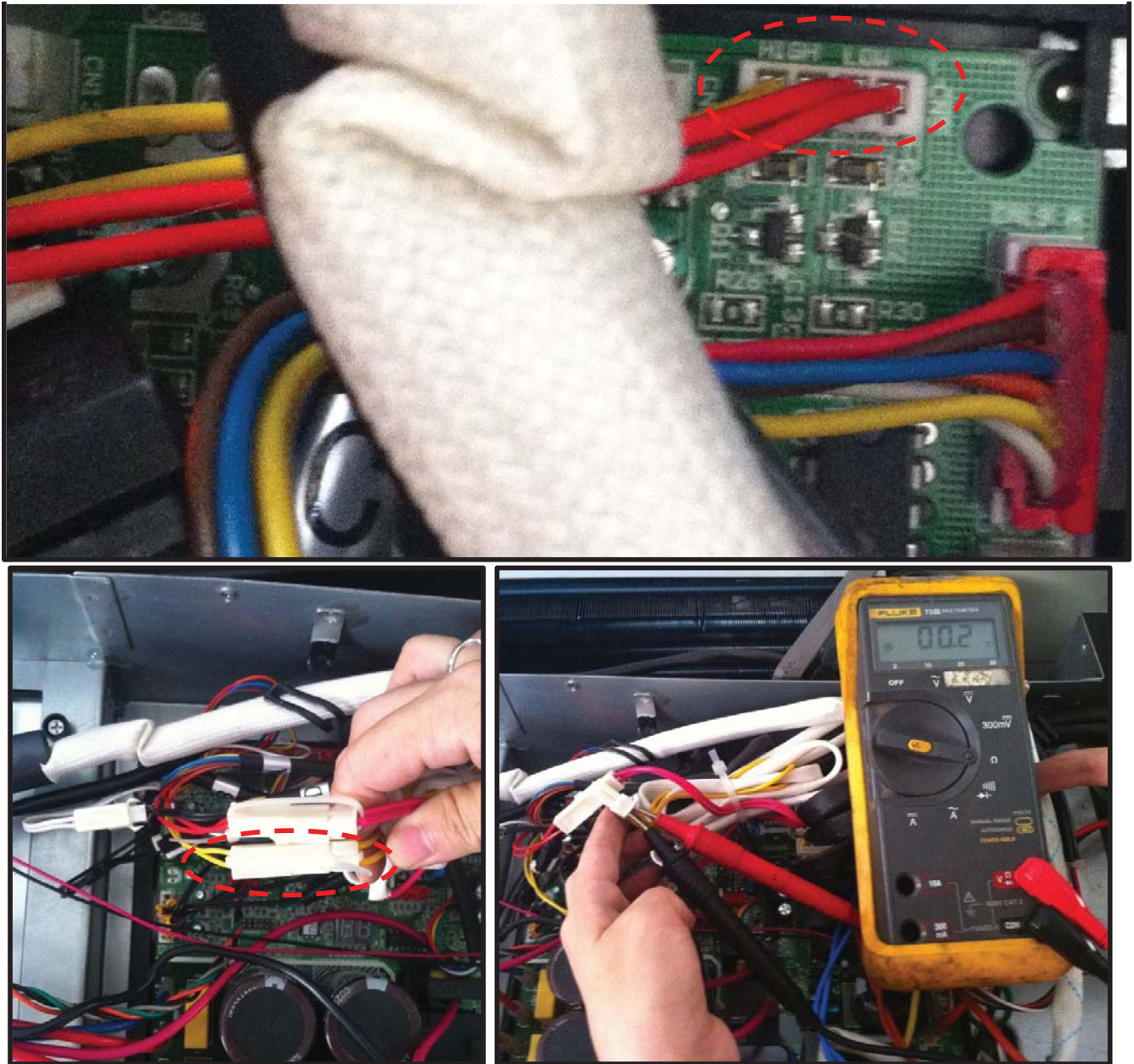

Fig. 59 – Test the voltage

DIAGNOSIS AND SOLUTION (CONT)

P2 (Low pressure protection) error

Table 48—Diagnosis and Solution

Error Code	P2
Malfunction decision conditions	If the sampling voltage is not 5V, the LED displays the failure.
Supposed causes	<ul style="list-style-type: none"> • Wiring mistake • Over load protector faulty • System block • Outdoor PCB faulty

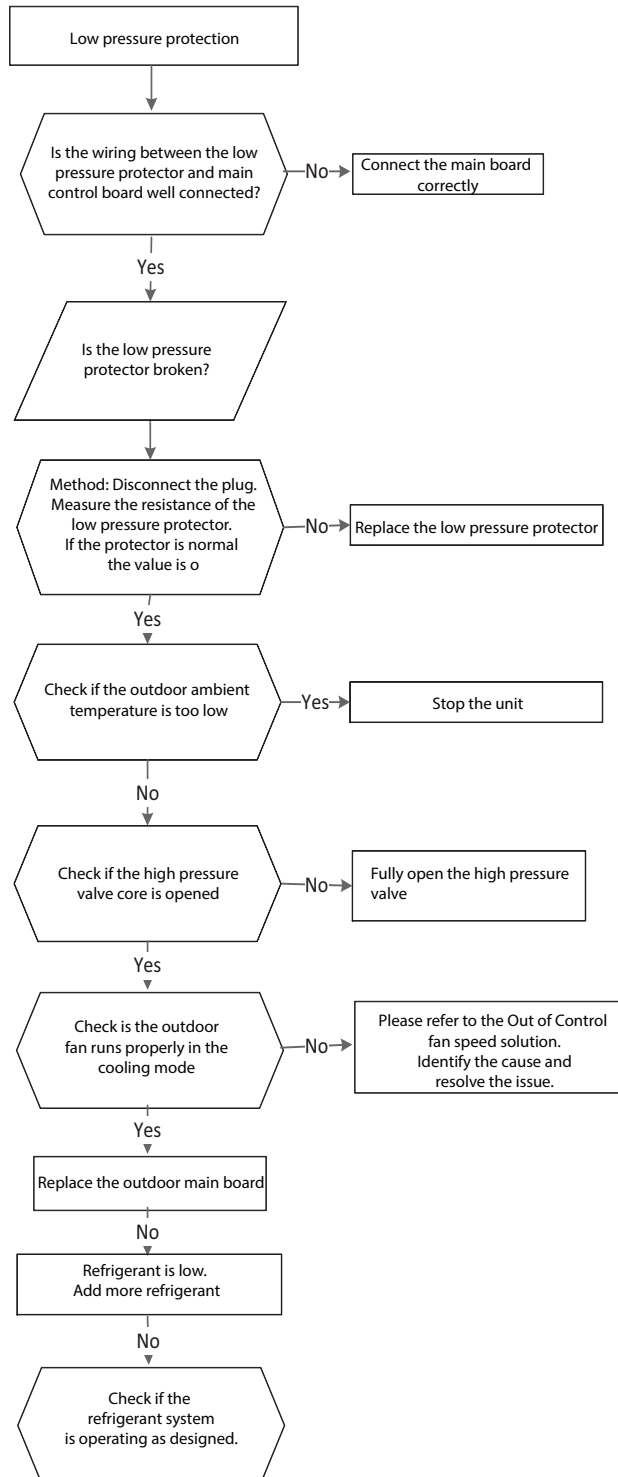

DIAGNOSIS AND SOLUTION (CONT)

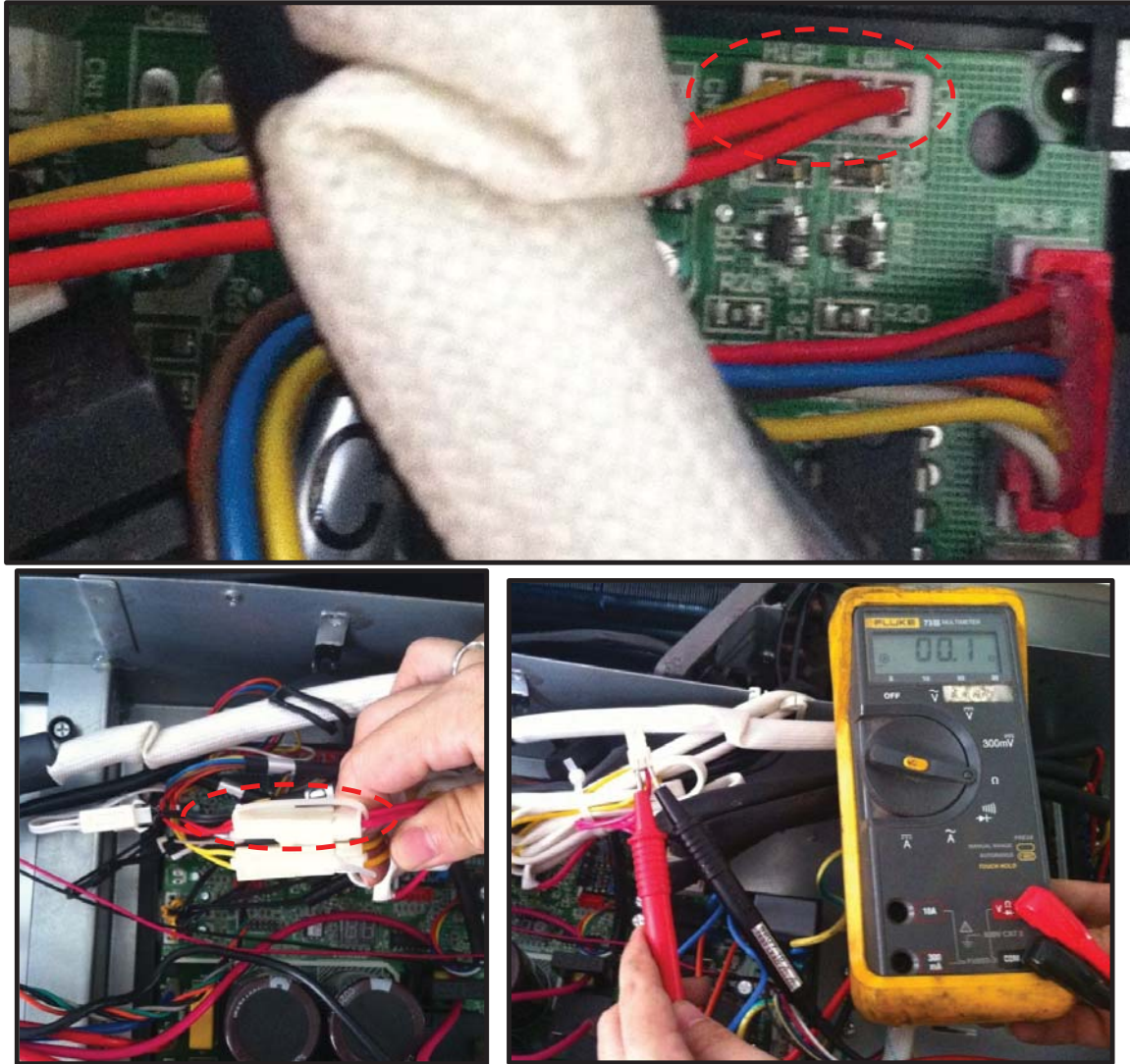

Fig. 60 – Test the voltage

DIAGNOSIS AND SOLUTION (CONT)

P3 (Current protection of compressor) error

Table 49—Diagnosis and Solution

Error Code	P3
Malfunction decision conditions	If the outdoor current exceeds the current limit value, the LED displays the failure.
Supposed causes	<ul style="list-style-type: none"> • Wiring mistake • Over load protector faulty • System block • Outdoor PCB faulty

Troubleshooting

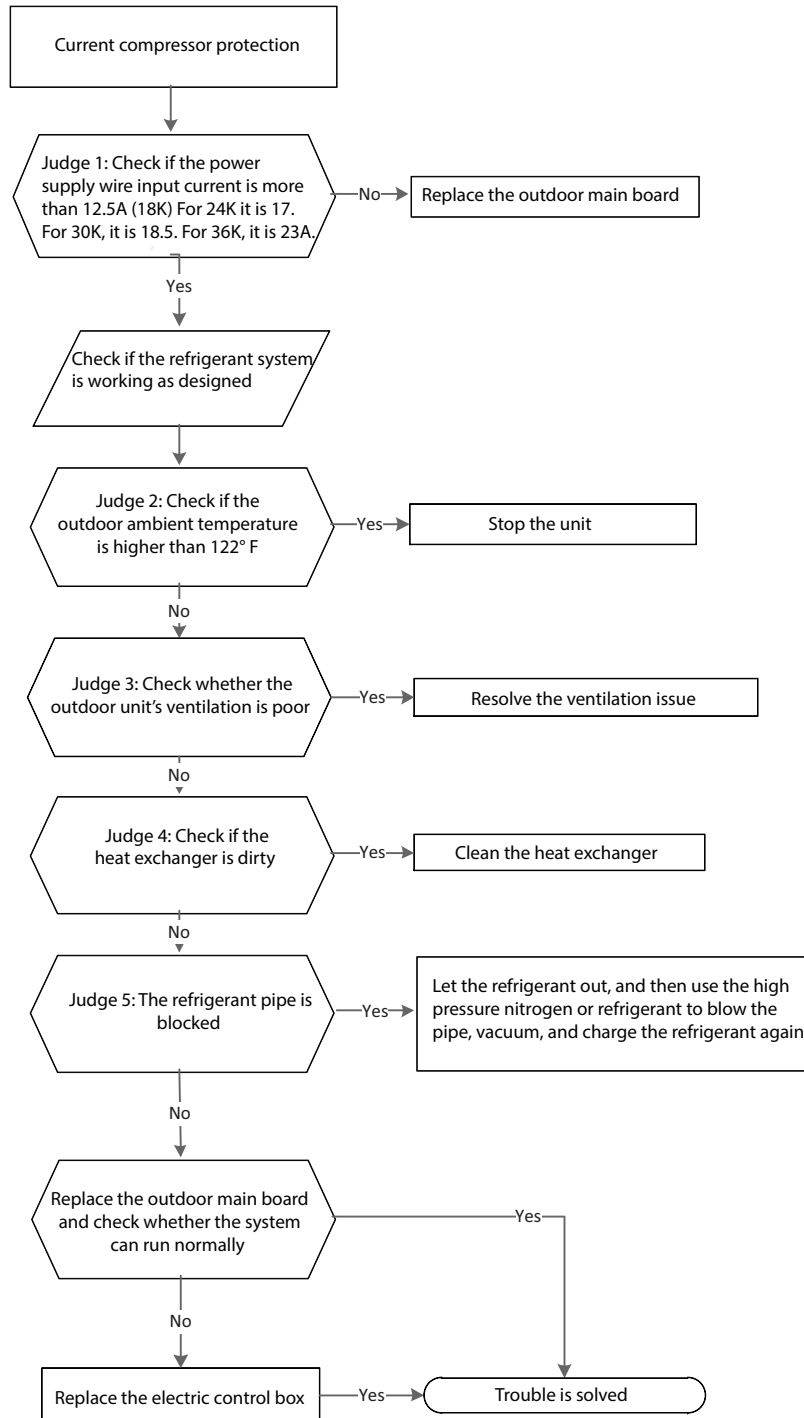

DIAGNOSIS AND SOLUTION (CONT)



Fig. 61 – Test the voltage

DIAGNOSIS AND SOLUTION (CONT)

P4 (Temperature protection of compressor discharge) error

Table 50—Diagnosis and Solution

Error Code	P4
Malfunction decision conditions	When the compressor discharge temperature (T5) is more than 239°F for 10 seconds, the compressor stops and restarts when T5 is less than 194°F.
Supposed causes	<ul style="list-style-type: none"> • Refrigerant leakage • Wiring mistake • The discharge temperature sensor faulty • Outdoor PCB faulty

Troubleshooting

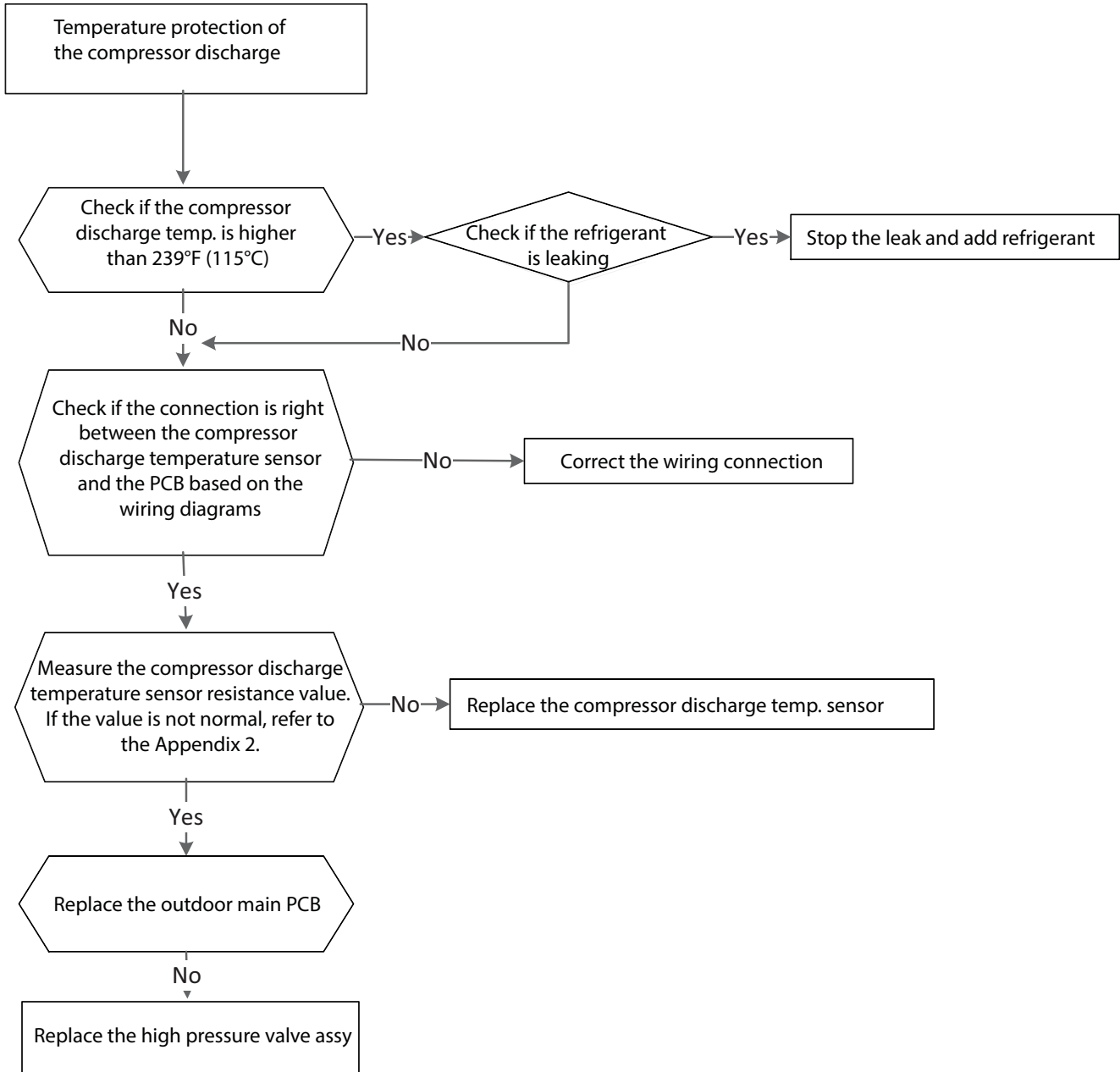

DIAGNOSIS AND SOLUTION (CONT)

P5 (High temperature protection of condenser) error

Table 51—Diagnosis and Solution

Error Code	P5
Malfunction decision conditions	When outdoor pipe temperature is more than 149°F, the unit stops, and unit runs again when the outdoor pipe temperature is less than 125°F.
Supposed causes	<ul style="list-style-type: none"> • The condenser temperature sensor faulty • Heat exchanger dirty • System block

Troubleshooting

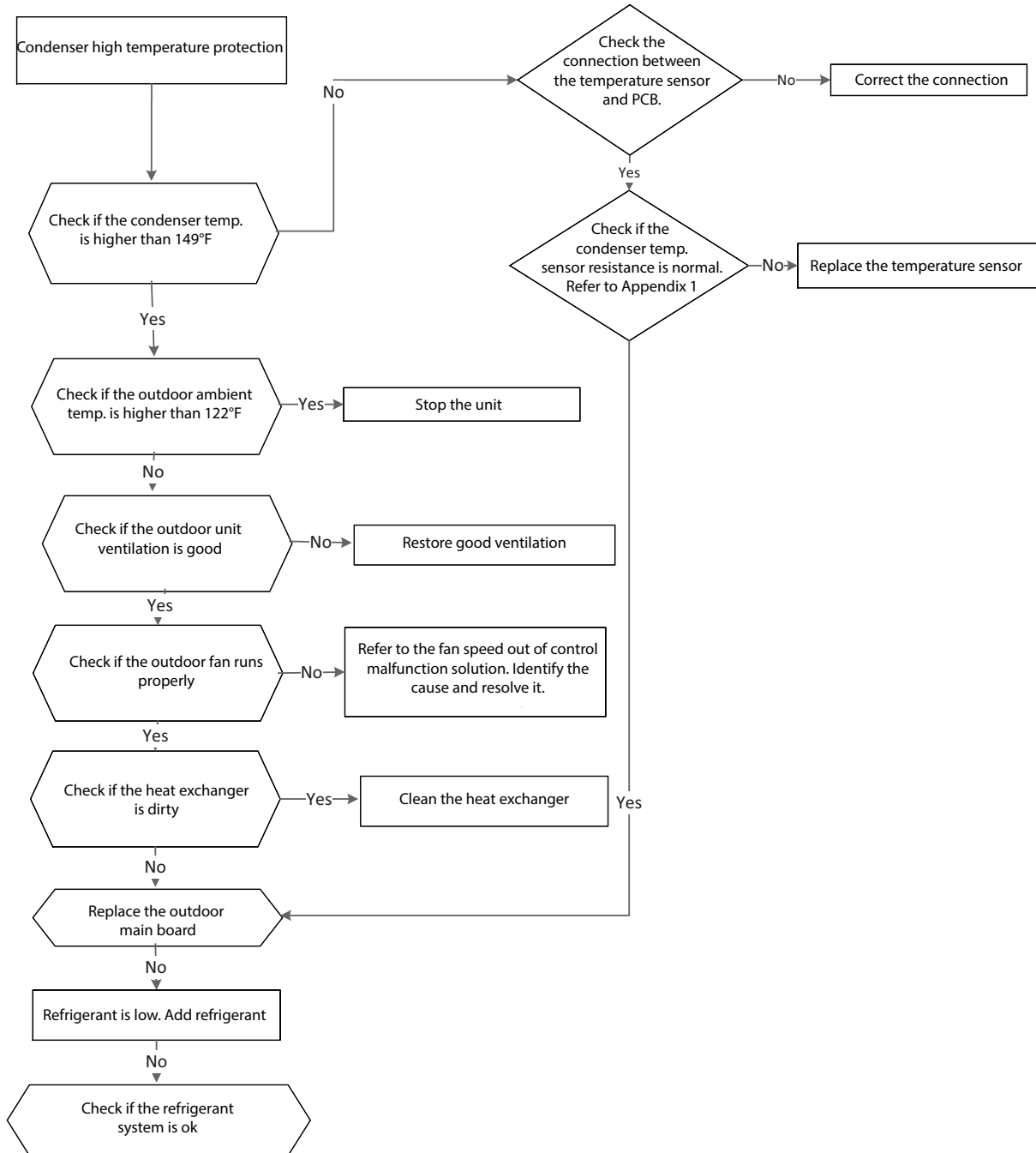

DIAGNOSIS AND SOLUTION (CONT)

P6 (IPM module protection) error

Table 52—Diagnosis and Solution

Error Code	P6
Malfunction decision conditions	When the voltage signal that IPM send to compressor drive chip is abnormal, the display LED shows “P6” and the AC turns off.
Supposed causes	<ul style="list-style-type: none"> • Wiring mistake • IPM malfunction • Outdoor fan ass’y faulty • Compressor malfunction • Outdoor PCB faulty

Troubleshooting

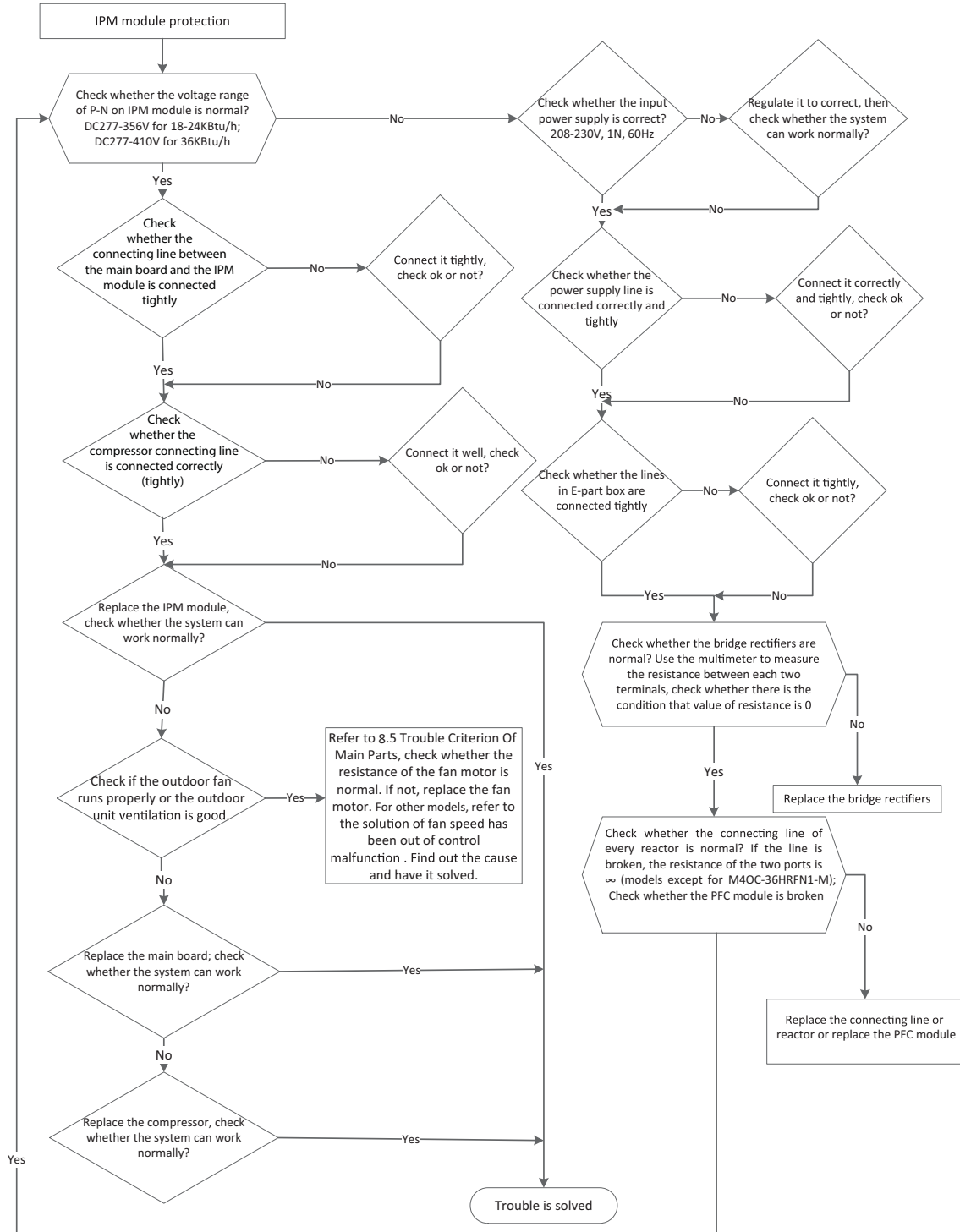

DIAGNOSIS AND SOLUTION (CONT)

The cooling operation or heating operation does not operate

Supposed cause:

- 4-way valve faulty

Check the 4-way valve. See *4-Way Valve* for more information.

When cooling, the heat exchanger of the non-operating indoor unit frosts. When heating, the non-operating indoor unit gets warm.

Supposed causes:

- EXV faulty
- Wire and tubing connected in reverse

Check the EXV.

Temperature Sensor Checking

Disconnect the temperature sensor from PCB, measure the resistance value with a tester.

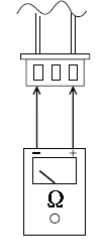

Tester

Temperature Sensors

Room temp.(T1) sensor,

Indoor coil temp.(T2) sensor,

Outdoor coil temp.(T3) sensor,

Outdoor ambient temp.(T4) sensor,

Compressor discharge temp.(T5) sensor.

Measure the resistance value of each winding by using the multi-meter.

APPENDIX 1

Table 53—Temperature Sensor Resistance Value (°C-K)

°C	K Ohm	°C	K Ohm	°C	K Ohm	°C	K Ohm
-20	115.266	20	12.6431	60	2.35774	100	0.62973
-19	108.146	21	12.0561	61	2.27249	101	0.61148
-18	101.517	22	11.5000	62	2.19073	102	0.59386
-17	96.3423	23	10.9731	63	2.11241	103	0.57683
-16	89.5865	24	10.4736	64	2.03732	104	0.56038
-15	84.2190	25	10.000	65	1.96532	105	0.54448
-14	79.3110	26	9.55074	66	1.89627	106	0.52912
-13	74.5360	27	9.12445	67	1.83003	107	0.51426
-12	70.1698	28	8.71983	68	1.76647	108	0.49989
-11	66.0898	29	8.33566	69	1.70547	109	0.48600
-10	62.2756	30	7.97078	70	1.64691	110	0.47256
-9	58.7079	31	7.62411	71	1.59068	111	0.45957
-8	56.3694	32	7.29464	72	1.53668	112	0.44699
-7	52.2438	33	6.98142	73	1.48481	113	0.43482
-6	49.3161	34	6.68355	74	1.43498	114	0.42304
-5	46.5725	35	6.40021	75	1.38703	115	0.41164
-4	44.0000	36	6.13059	76	1.34105	116	0.40060
-3	41.5878	37	5.87359	77	1.29078	117	0.38991
-2	39.8239	38	5.62961	78	1.25423	118	0.37956
-1	37.1988	39	5.39689	79	1.21330	119	0.36954
0	35.2024	40	5.17519	80	1.17393	120	0.35982
1	33.3269	41	4.96392	81	1.13604	121	0.35042
2	31.5635	42	4.76253	82	1.09958	122	0.3413
3	29.9058	43	4.57050	83	1.06448	123	0.33246
4	28.3459	44	4.38736	84	1.03069	124	0.32390
5	26.8778	45	4.21263	85	0.99815	125	0.31559
6	25.4954	46	4.04589	86	0.96681	126	0.30754
7	24.1932	47	3.88673	87	0.93662	127	0.29974
8	22.5662	48	3.73476	88	0.90753	128	0.29216
9	21.8094	49	3.58962	89	0.87950	129	0.28482
10	20.7184	50	3.45097	90	0.85248	130	0.27770
11	19.6891	51	3.31847	91	0.82643	131	0.27078
12	18.7177	52	3.19183	92	0.80132	132	0.26408
13	17.8005	53	3.07075	93	0.77709	133	0.25757
14	16.9341	54	2.95896	94	0.75373	134	0.25125
15	16.1156	55	2.84421	95	0.73119	135	0.24512
16	15.3418	56	2.73823	96	0.70944	136	0.23916
17	14.6181	57	2.63682	97	0.68844	137	0.23338
18	13.9180	58	2.53973	98	0.66818	138	0.22776
19	13.2631	59	2.44677	99	0.64862	139	0.22231

APPENDIX 2

Table 54—Unit °C Discharge Temperature Sensor (°C-K)

-20	542.7	20	68.66	60	13.59	100	3.702
-19	511.9	21	65.62	61	13.11	101	3.595
-18	483	22	62.73	62	12.65	102	3.492
-17	455.9	23	59.98	63	12.21	103	3.392
-16	430.5	24	57.37	64	11.79	104	3.296
-15	406.7	25	54.89	65	11.38	105	3.203
-14	384.3	26	52.53	66	10.99	106	3.113
-13	363.3	27	50.28	67	10.61	107	3.025
-12	343.6	28	48.14	68	10.25	108	2.941
-11	325.1	29	46.11	69	9.902	109	2.86
-10	307.7	30	44.17	70	9.569	110	2.781
-9	291.3	31	42.33	71	9.248	111	2.704
-8	275.9	32	40.57	72	8.94	112	2.63
-7	261.4	33	38.89	73	8.643	113	2.559
-6	247.8	34	37.3	74	8.358	114	2.489
-5	234.9	35	35.78	75	8.084	115	2.422
-4	222.8	36	34.32	76	7.82	116	2.357
-3	211.4	37	32.94	77	7.566	117	2.294
-2	200.7	38	31.62	78	7.321	118	2.233
-1	190.5	39	30.36	79	7.086	119	2.174
0	180.9	40	29.15	80	6.859	120	2.117
1	171.9	41	28	81	6.641	121	2.061
2	163.3	42	26.9	82	6.43	122	2.007
3	155.2	43	25.86	83	6.228	123	1.955
4	147.6	44	24.85	84	6.033	124	1.905
5	140.4	45	23.89	85	5.844	125	1.856
6	133.5	46	22.89	86	5.663	126	1.808
7	127.1	47	22.1	87	5.488	127	1.762
8	121	48	21.26	88	5.32	128	1.717
9	115.2	49	20.46	89	5.157	129	1.674
10	109.8	50	19.69	90	5	130	1.632
11	104.6	51	18.96	91	4.849		
12	99.69	52	18.26	92	4.703		
13	95.05	53	17.58	93	4.562		
14	90.66	54	16.94	94	4.426		
15	86.49	55	16.32	95	4.294	B(25/50)=3950K	
16	82.54	56	15.73	96	4.167		
17	78.79	57	15.16	97	4.045	R(90°C)=5KΩ±3%	
18	75.24	58	14.62	98	3.927		
19	71.86	59	14.09	99	3.812		

APPENDIX 3

Table 55—°C and °F

°C	10	11	12	13	14	15	16	17	18	19	20	21	22
°F	48	50	52	54	56	58	60	62	64	66	68	70	72
°C	23	24	25	26	27	28	29	30	31	32	33	34	35
°F	74	76	78	80	82	84	86	88	90	92	94	96	98

Compressor Check

Measure the resistance value of each winding by using the tester.

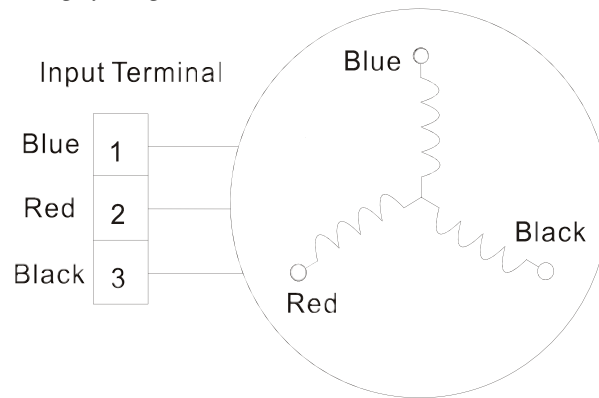

Fig. 62 – Measure the Resistance

Table 56—Compressor Check

POSITION	RESISTANCE VALUE				
	ATM150D23UFZ	ATF235D22UMT	ATF250D22UMT	ATF310D43UMT	ATQ360D1UMU
BLUE – RED	1.72 Ω	0.75 Ω	0.75 Ω	0.65 Ω	0.37 Ω



Fig. 63 – Test the voltage

IPM Continuity Check

Turn off the power, let the large capacity electrolytic capacitors discharge completely, and dismount the IPM. Use a digital tester to measure the resistance between P and UVWN; UVW and N.

Table 57—IPM Continuity Check

Digital Tester		Normal Resistance Value	Digital Tester		Normal Resistance Value
(+)Red	(-)Black		(+)Red	(-)Black	
P	N	∞ (Several M Ω)	U	N	∞ (Several M Ω)
	U				
	V				
	W				
			(+)Red		

AC Fan Motor

Measure the resistance value of each winding by using the tester.

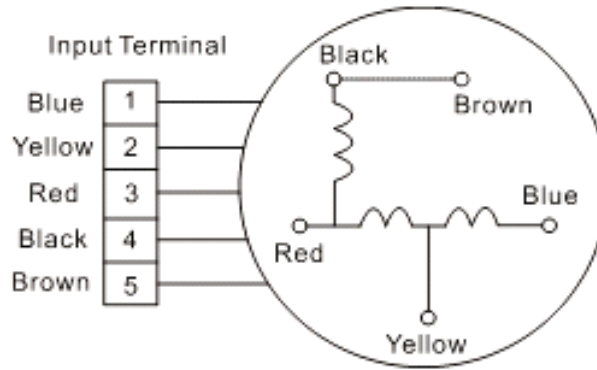

Table 58—Resistance Value

Position	Resistance Value			
	RPG20B		RPG28H	
Black - Red	381 Ω ±8% (68 °F)	342 Ω ±8% (68 °F)	183.6 Ω ±8% (68 °F)	180 Ω ±8% (68 °F)
White - Black	267 Ω ±8% (68 °F)	253 Ω ±8% (68 °F)	206 Ω ±8% (68 °F)	190 Ω ±8% (68 °F)

Measure the resistance value of each winding by using the tester.

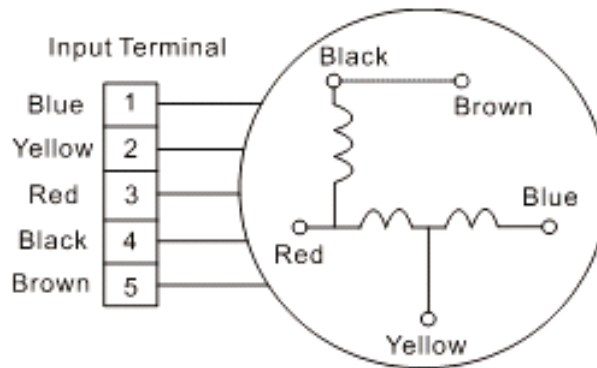

Table 59—Resistance Value

Position	Resistance Value						
	YDK70-6FB	YDK180-8GB	YSK27-4G	YSK68-4B	YDK45-6B	YSK25-6L	YDK53-6FB(B)
Black– Red (68°F)	56 Ω ±8%	24.5 Ω ±8%	317 Ω ±8%	145 Ω ±8%	345 Ω ±8%	627 Ω ±8%	88.5 Ω ±8%
Red– Yellow (68°F)	76 Ω ±8%	19 Ω ±8%	252 Ω ±8%	88 Ω ±8%	150 Ω ±8%	374.3 Ω ±8%	138 Ω ±8%
Yellow– Blue (68°F)	76 Ω ±8%	19 Ω ±8%	252 Ω ±8%	88 Ω ±8%	150 Ω ±8%	374.3 Ω ±8%	138 Ω ±8%

4-Way Valve

1 Power on, use a digital tester to measure the voltage, when the unit operates in cooling, it is 0V. When the unit operates in the Heating mode, it is about 230VAC. If the value of the voltage is not in the range, the PCB needs to be replaced.

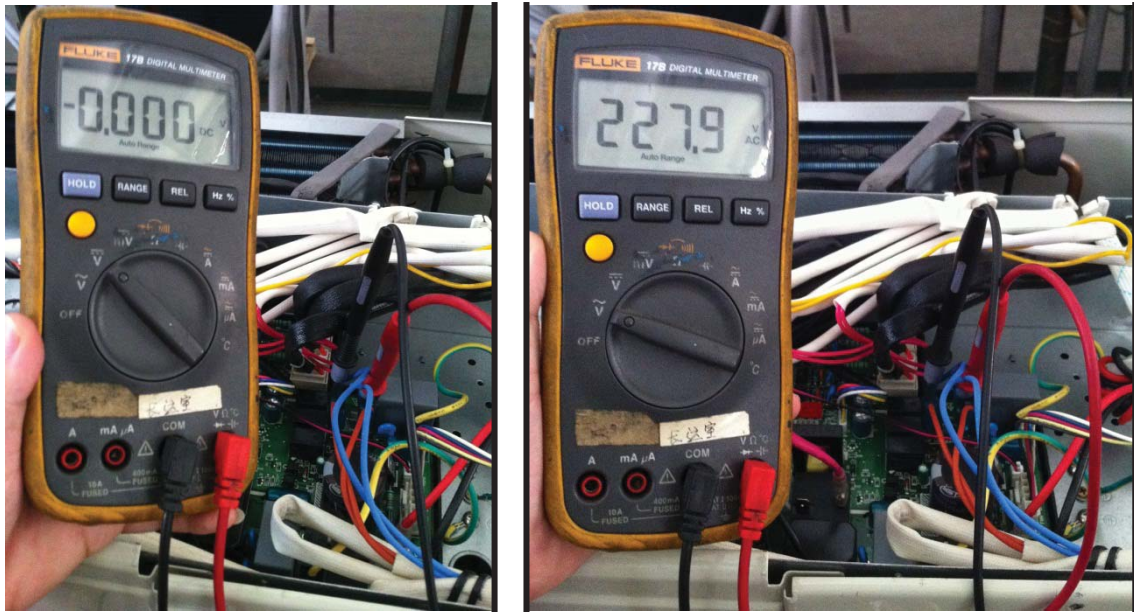

Fig. 64 – Test the voltage

2 Turn off the power, use a digital tester to measure the resistance. The value should be 1.8~2.5 K Ω .

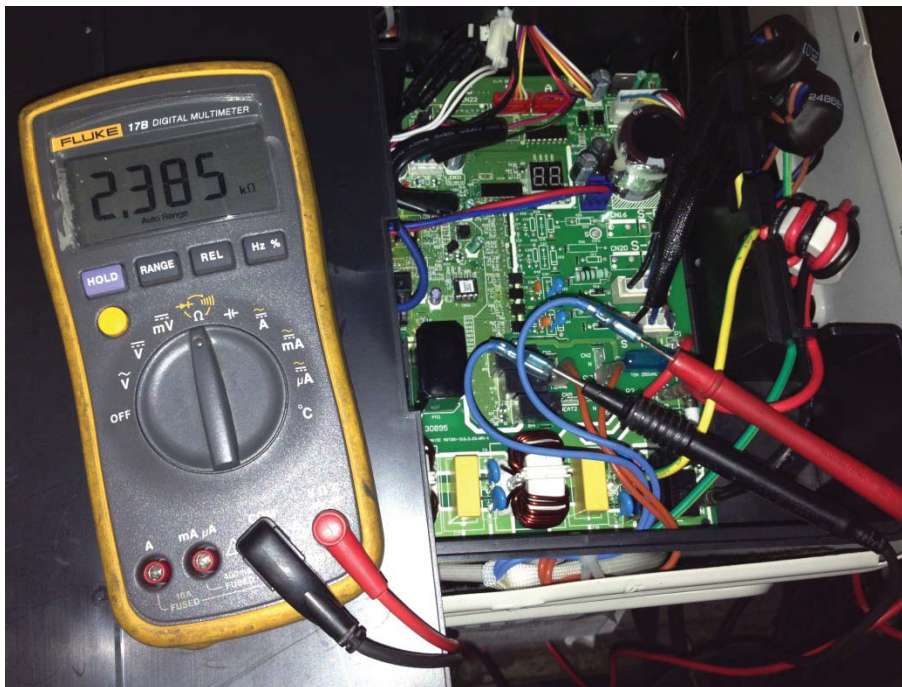

Fig. 65 – Test the Resistance

EXV Check

1 Disconnect the connectors.

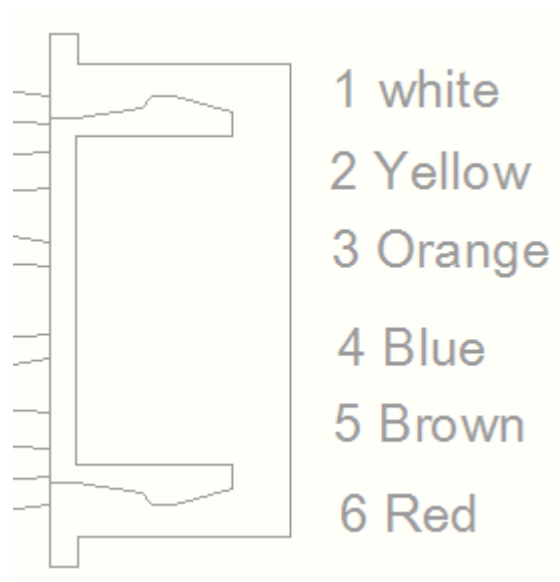

Fig. 66 – Disconnect the connectors

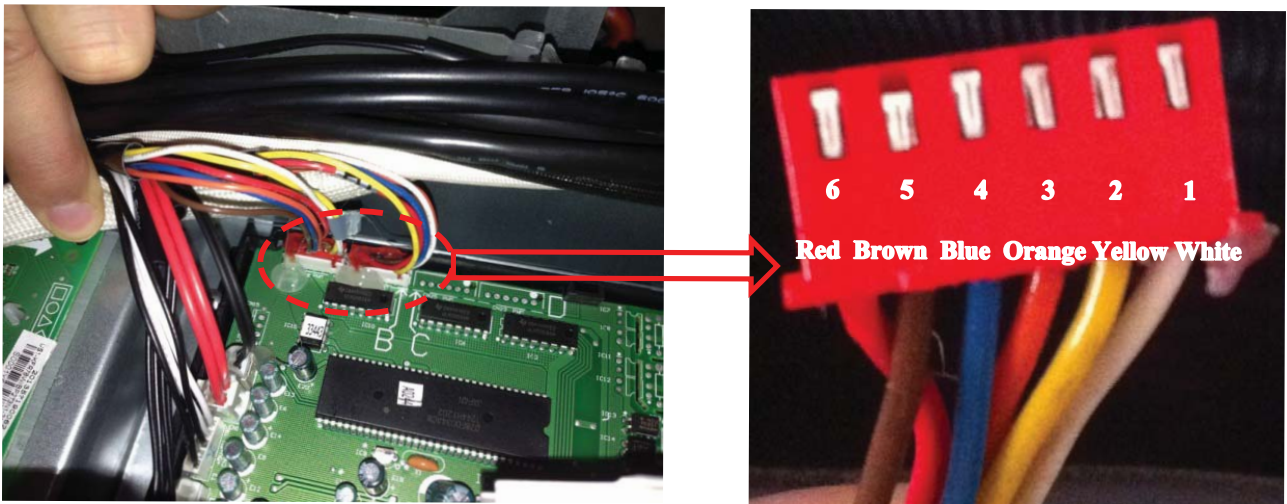
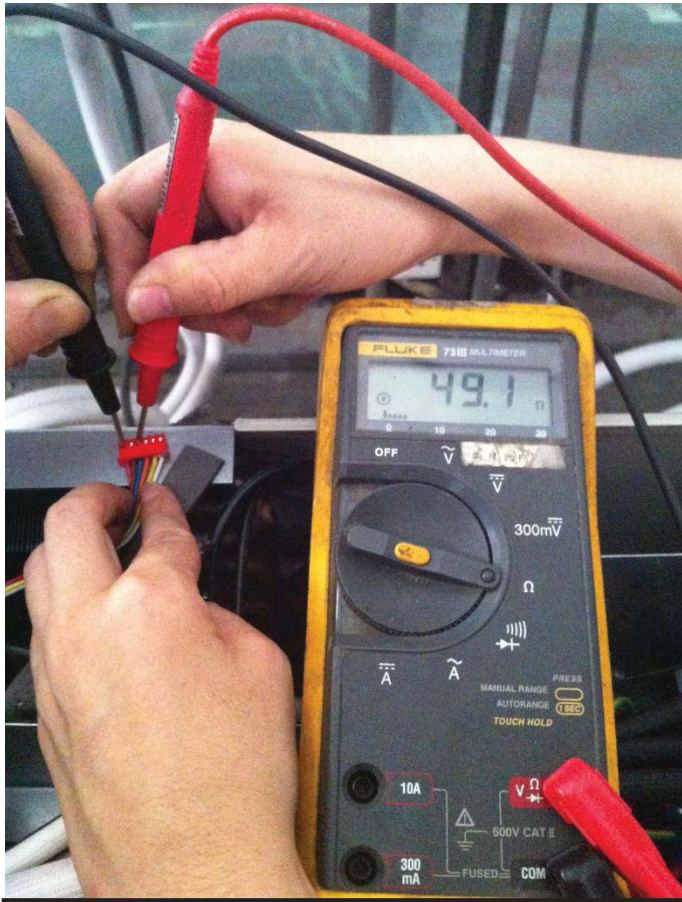

Table 60—Resistance to EXV Coil

LEAD WIRE COLOR	NORMAL VALUE
Red - Blue	About 50Ω
Red - Yellow	
Brown - Orange	
Brown - White	

EXV Check (CONT)



Red- Blue

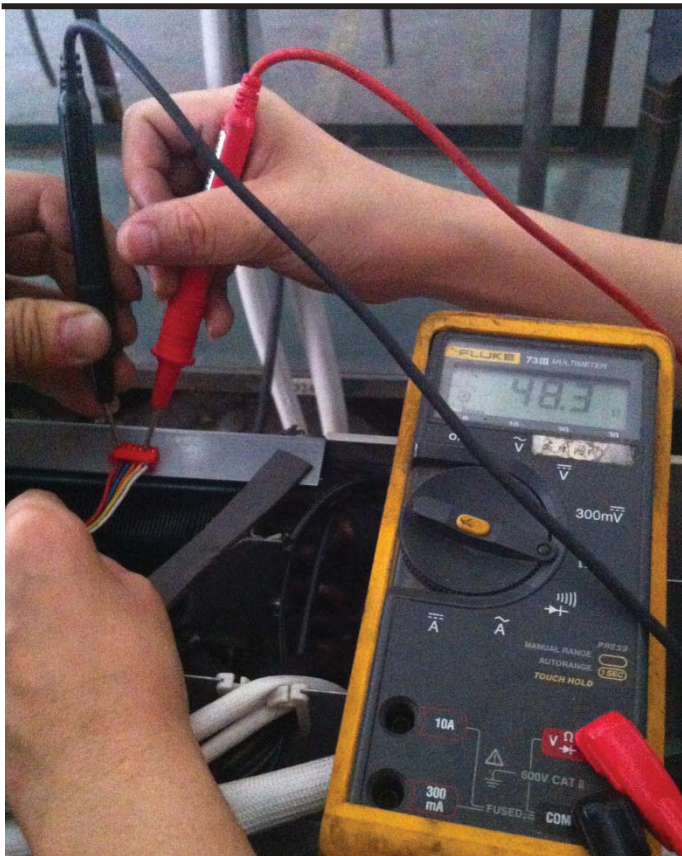

Red - Yellow

EXV Check (CONT)

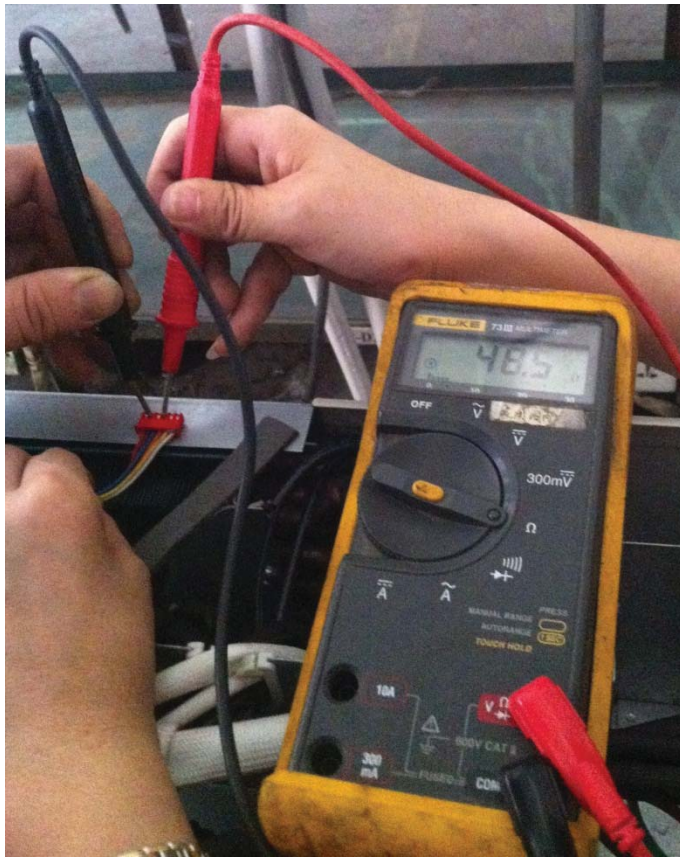

Brown-Orange

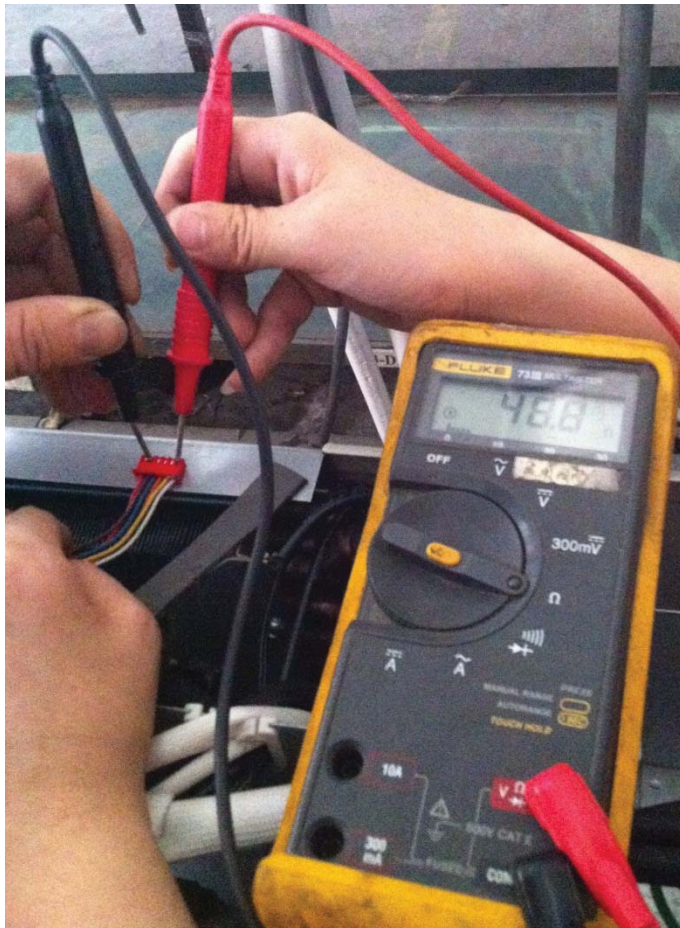



Brown-White

DISASSEMBLY INSTRUCTIONS SIZE 18

NOTE: This section is for reference and the photos may have differ slightly from your unit.

No.	Part name	Procedures	Remarks
1	Fan assembly	<p>How to remove the fan assembly.</p> <ol style="list-style-type: none"> 1) Turn off the air conditioner and turn off the power breaker. 2) Remove the screws of air outlet grille (4 screws). 3) Remove hex nut securing the fan. 4) Remove the fan. 5) Remove the top cover screws, and remove the top cover. (3 screws) 	

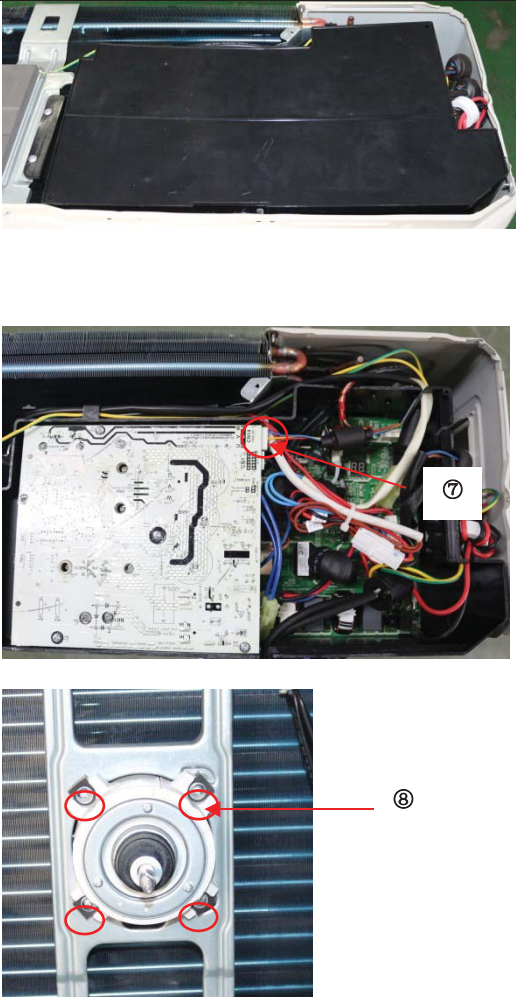
DISASSEMBLY INSTRUCTIONS SIZE 18 (CONT)

		<p>6) Remove the electrical control box cover.</p> <p>7) Disconnect the fan motor connector CN14 (3p, white) from the IPM board.</p> <p>8) Remove the fan motor after unfastening the four screws.</p>	
2	Panel plate	<p>How to remove the panel plate.</p> <p>1) Remove the front panel screws then remove the front panel (6 screws).</p>	

DISASSEMBLY INSTRUCTIONS SIZE 18 (CONT)



2) Remove the big handle screws, and remove the big handle (4 screws).



3) Remove the terminal board screws (2) and the right-rear panel screws (7), then remove the right rear panel.

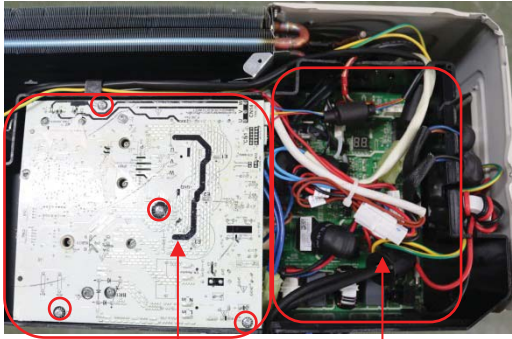

DISASSEMBLY INSTRUCTIONS SIZE 18 (CONT)

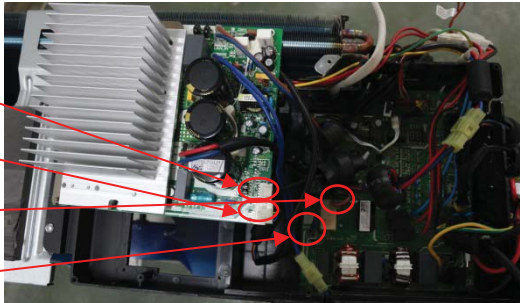
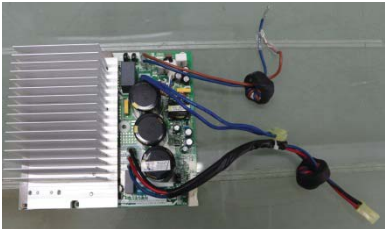
<p>3</p>	<p>Electrical parts</p>	<p>How to remove the electrical parts.</p> <ol style="list-style-type: none"> 1) Complete the steps in sections 1 & 2. 2) Remove the four (4) screws securing the IPM board. 3) Unfasten the reactor connector. 4) Unfasten the compressor connector. 5) Disconnect the following three (3) connection wires and connectors between the IPM and the main control PCB: <ul style="list-style-type: none"> CN1(5p,white) CN14(3p,white) CN4(red or brown) CN5(blue) 6) Remove the IPM board. 7) Disconnect the connectors and wires connected from PCB and other parts. 	 <p style="text-align: center;">IPM board PCB board</p>   
----------	-------------------------	---	---

DISASSEMBLY INSTRUCTIONS SIZE 18 (CONT)

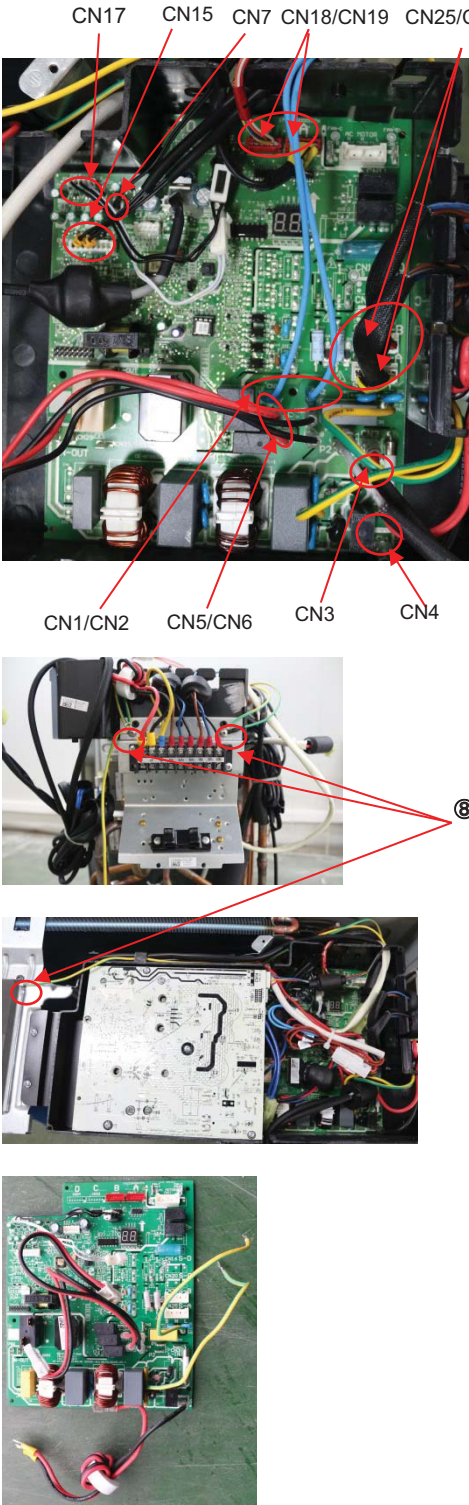
	<p>Connectors:</p> <p>CN17:T3/T4 temperature sensor (2p/2p,white)</p> <p>CN7: Discharge temperature (2p,white)</p> <p>CN15:T2B-A,B temperature sensor (2p/2p,white)</p> <p>CN18/CN19: Electronic expansive valve A,B (6p/6p,red/red)</p> <p>CN25/CN23: S-A,S-B (3p/3p,white/white)</p> <p>Wires:</p> <p>CN1/CN2: 4-way valve (blue-blue)</p> <p>CN5/CN6: Crankcase heating cable (red-red)</p> <p>CN3:L-IN (red)</p> <p>CN4:N-IN (black)</p> <p>8) Disconnect the grounding wire (yellow-green) after removing the big handle and the right-rear panel.</p> <p>9) Remove the PCB board.</p>	
--	---	---

DISASSEMBLY INSTRUCTIONS SIZE 18 (CONT)

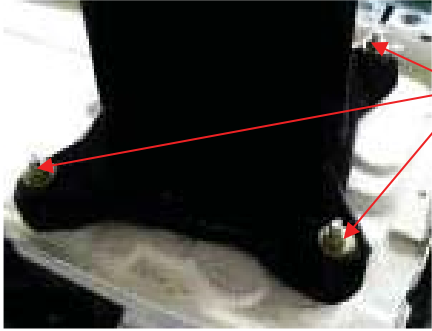
4	Compressor	<p>How to remove the compressor.</p> <ol style="list-style-type: none">1) Complete steps in section 1 & 2.2) Remove the electrical control box cover.3) Extract the refrigerant gas.4) Remove the sound insulation material and crankcase heating cable.5) Remove the compressor terminal cover and disconnect the crankcase electric heater and compressor from the terminal.6) Remove the discharge pipe and suction pipe with a burner.7) Remove the hex nuts and washers securing the compressor to the bottom plate.8) Lift the compressor.	 
---	------------	---	---

DISASSEMBLY INSTRUCTIONS SIZE 18 (CONT)

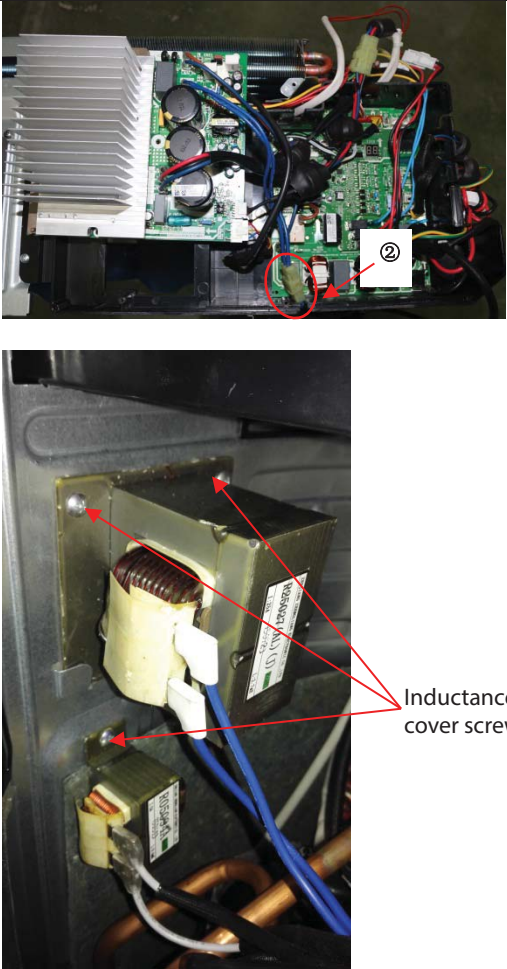
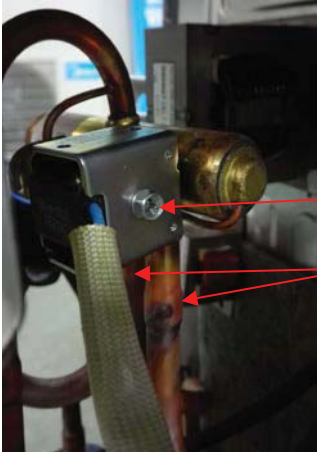
5	Reactor	<p>How to remove the reactor</p> <ol style="list-style-type: none"> 1) Complete steps in section 2. 2) Unfasten the connector between the IPM and the reactor. 3) Remove the reactor's three (3) screws and remove the reactor. 	
6	The 4-way valve	<p>How to remove the 4-way valve</p> <ol style="list-style-type: none"> 1) Complete steps in section 2. 2) Extract the refrigerant gas. 3) Remove the electrical parts (see section 3). 4) Remove the screw securing the coil and remove the coil. 5) Detach the welded parts of the 4-way valve and pipe. 	

DISASSEMBLY INSTRUCTIONS SIZE 18 (CONT)

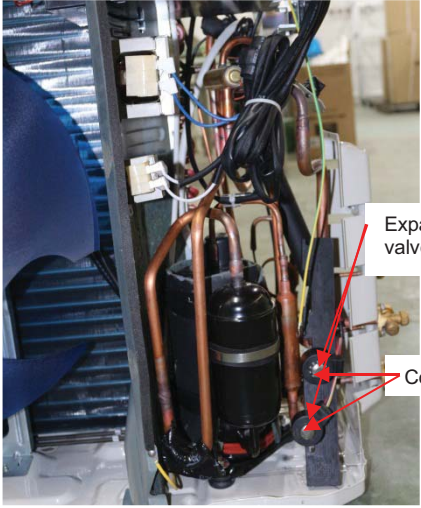
7	The expansion valve	<p>How to remove the expansion valve</p> <ol style="list-style-type: none"> 1) Complete the steps in sections 1 & 2. 2) Remove the electrical parts from section 3. 3) Remove the coils. 4) Detach the welded parts of the expansion valves and pipes. 	 <p>Expansion valves</p> <p>Coils</p>
---	---------------------	--	---

DISASSEMBLY INSTRUCTIONS SIZE 24

No.	Part name	Procedures	Remarks
1	Panel plate	<p>How to remove the panel plate.</p> <ol style="list-style-type: none"> 1) Turn off the air conditioner. Turn off the power breaker. 2) Remove the big handle screws (4), then remove the big handle. 3) Remove the top cover screws and remove the top cover. 4) Remove the right-front side panel screws and remove the right front side panel (1 screws). 5) Remove the front panel screws (8) and remove the front panel. 	 <p>Big handle screws</p> <p>Top cover screws</p> <p>Top cover screws</p>

DISASSEMBLY INSTRUCTIONS SIZE 24 (CONT)

6) Remove the terminal board screws (2), the water collector screws, and the right-rear panel screws (15) and then remove the right-rear panel.

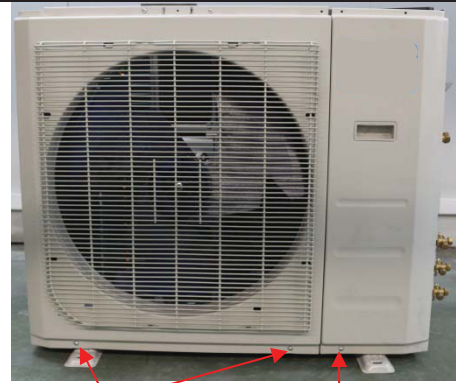

Front panel screws

Right front side panel screws



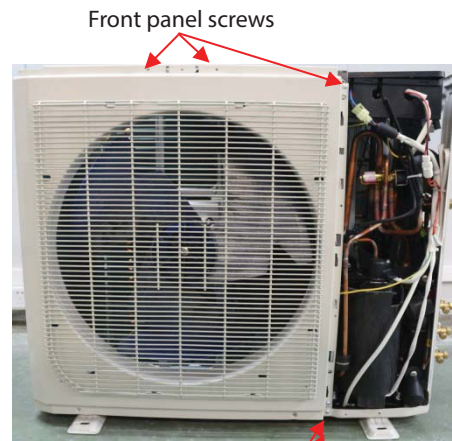

Front panel screws



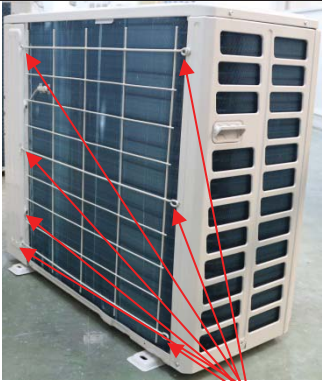
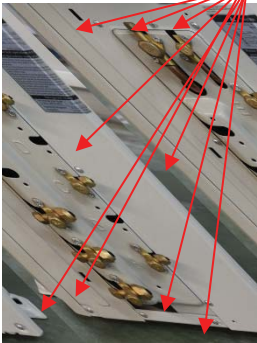
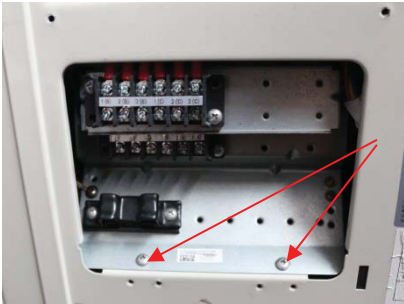

Front panel screws

Front panel screws

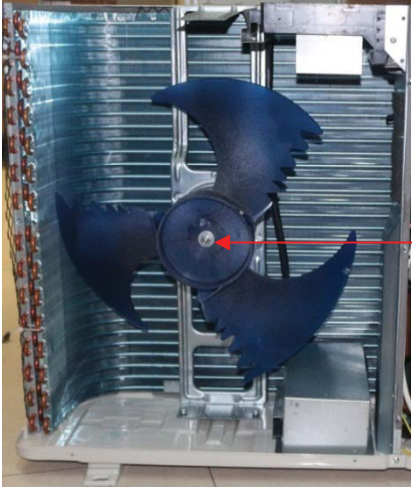

DISASSEMBLY INSTRUCTIONS SIZE 24 (CONT)

			 <p>Right-rear panel screws</p>  <p>Terminal board screws</p>  <p>Terminal board screws</p> 
--	--	--	---

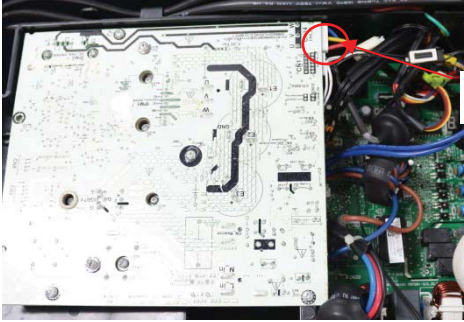
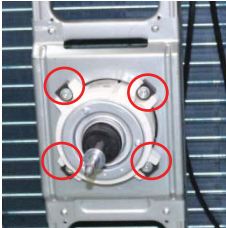
DISASSEMBLY INSTRUCTIONS SIZE 24 (CONT)

2	Fan assembly	<p>How to remove the fan assembly.</p> <ol style="list-style-type: none">1) Remove the top cover, right front side panel and the front panel (see section 1, steps 1 - 4).2) Remove the hex nut securing the fan.3) Remove the fan.4) Remove the electrical control box.5) Disconnect the fan motor connector CN14 (5p,white) from the IPM board.6) Remove the four screws securing the fan motor then remove the fan motor.	   
---	--------------	---	--

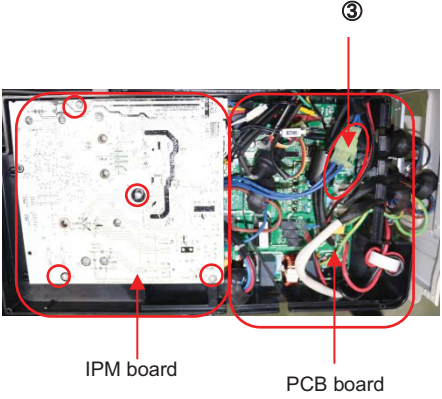
DISASSEMBLY INSTRUCTIONS SIZE 24 (CONT)

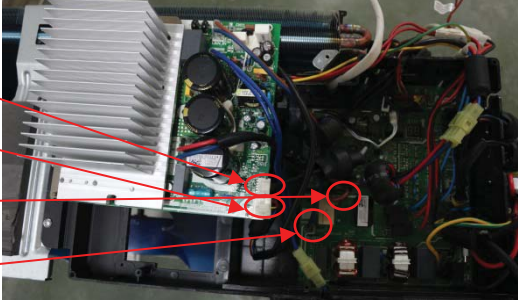
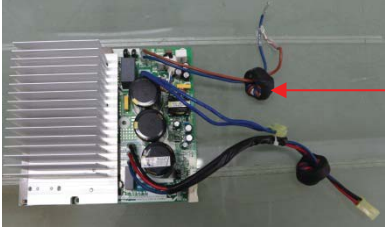
<p>3</p>	<p>Electrical parts</p>	<p>How to remove the electrical parts.</p> <ol style="list-style-type: none"> 1) Complete the steps in sections 1 & 2. 2) Remove the four screws (4) securing the IPM board. 3) Unfasten the reactor connector. 4) Unfasten the compressor connector. 5) Disconnect the following connection wires and connectors between the IPM and the PCB: <ul style="list-style-type: none"> CN1(5p,white) CN14(3p,white) CN3(red or brown) CN5(blue) 6) Remove the IPM board. 	 <p>IPM board PCB board</p>   
----------	-------------------------	--	---

DISASSEMBLY INSTRUCTIONS SIZE 24 (CONT)

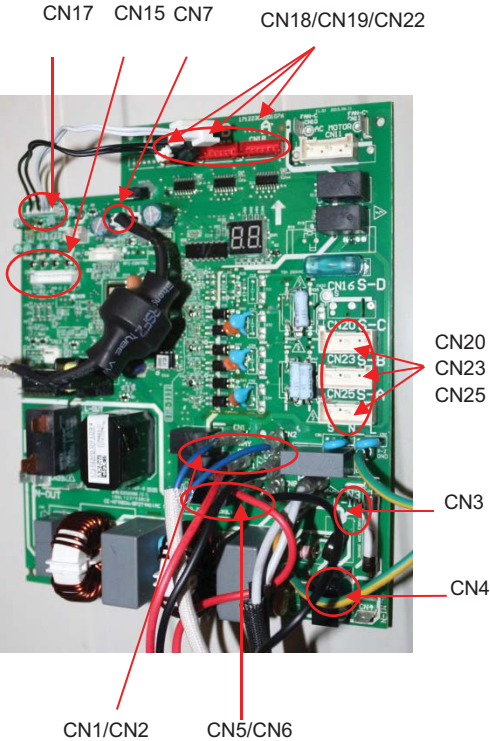
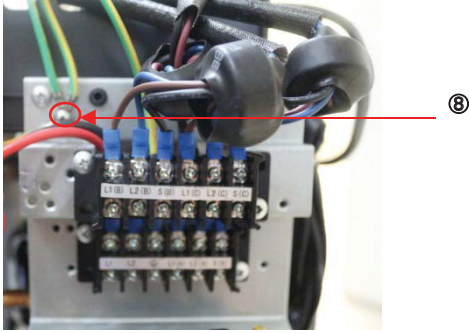
		<p>7) Disconnect the connectors and wires connected to the PCB and other parts.</p> <p>Connectors:</p> <p>CN17:T3/T4 temperature sensor (2p/2p,white)</p> <p>CN7: Discharge temperature sensor (2p,white)</p> <p>CN12:Ttop temperature sensor(2p,white)</p> <p>CN15:T2B-A,B,C temperature sensor (2p/2p/2p,white)</p> <p>CN18/CN19/CN22: Electronic expansive valve A,B,C (6p/6p/6p,red/red/red)</p> <p>CN25/CN23/CN20: S-A,S-B,S-C (3p/3p/3p,white/white/white)</p> <p>Wires:</p> <p>CN1/CN2: 4-way valve (blue-blue)</p> <p>CN5/CN6: Crankcase heating cable (red-red)</p> <p>CN3:L1-IN (red)</p> <p>CN4:L2-IN (black)</p>	 <p>CN17 CN15 CN7 CN18/CN19/CN22</p> <p>CN20 CN23 CN25</p> <p>CN3 CN4</p> <p>CN1/CN2 CN5/CN6</p> <p>8) Disconnect the grounding wire (yellow-green) after removing the big handle and the right-rear panel.</p>  <p>⑧</p> <p>9) Remove the PCB board.</p>
--	--	--	---

DISASSEMBLY INSTRUCTIONS SIZE 24 (CONT)

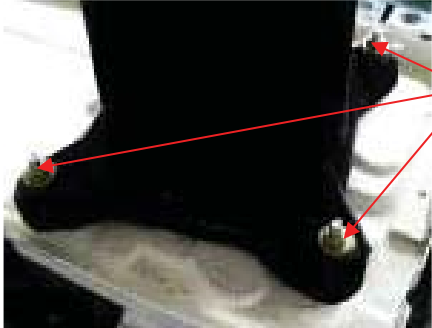
4	Compressor	<p>How to remove the compressor</p> <ol style="list-style-type: none">1) Complete steps in sections 1, 2, and 3.2) Remove the electrical control box and partition plate.3) Extract the refrigerant gas.4) Remove the sound insulation material and crankcase heating cable.5) Remove the compressor terminal cover, the compressor thermo disconnect wires and the compressor from the terminal.6) Remove the discharge pipe and the suction pipe with a burner.7) Remove the hex nuts and washers securing the compressor to the bottom plate.8) Lift the compressor.	 
---	------------	--	---

DISASSEMBLY INSTRUCTIONS SIZE 24 (CONT)

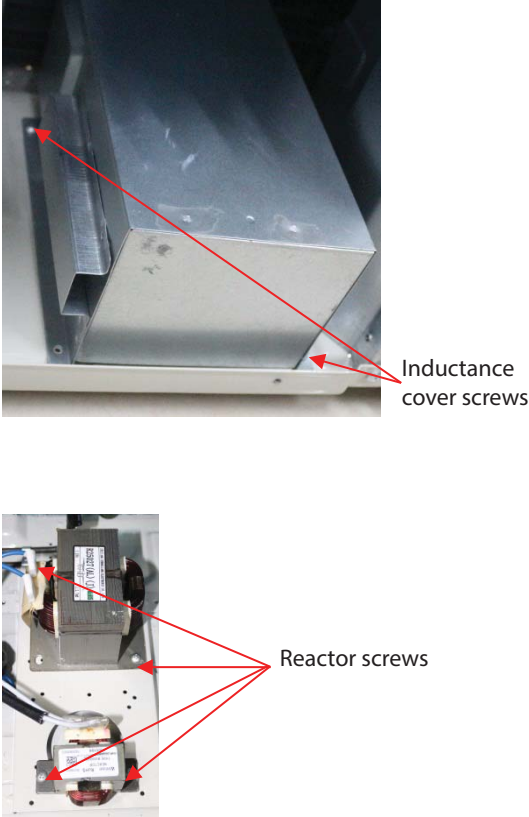
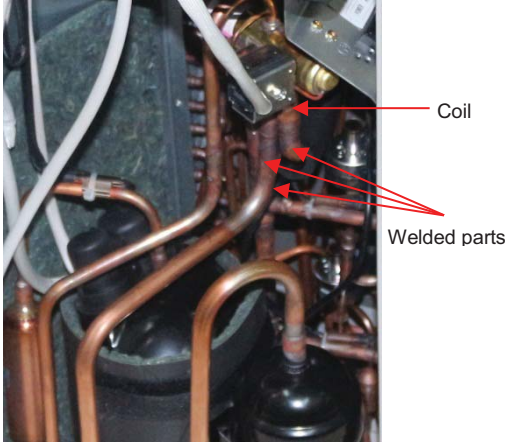
5	Reactor	<p>How to remove the reactor</p> <ol style="list-style-type: none"> 1) Complete the steps in sections 1 & 2. 2) Unfasten the connector between the IPM and the reactor. 3) Remove the inductance cover screws (2) then remove the inductance cover. 4) Disconnect the two wires connected to the inductance cover. 5) Remove the four (4) reactor screws, then remove the reactor. 	
6	The 4-way valve	<p>How to remove the 4-way valve</p> <ol style="list-style-type: none"> 1) Complete the steps in sections 1 and 2. 2) Extract the refrigerant gas. 3) Remove the electrical parts (see section 3). 4) Remove the screw securing the coil then remove the coil. 5) Detach the welded parts of the 4-way valve and pipe. 	

DISASSEMBLY INSTRUCTIONS SIZE 24 (CONT)

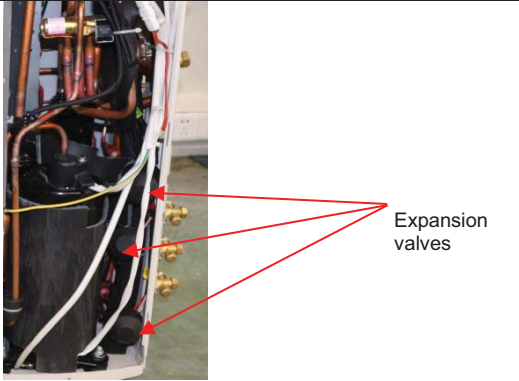
7	The expansion valve	<p>How to remove the expansion valve</p> <ol style="list-style-type: none"> 1) Complete steps in sections 1 and 2. 2) Remove the electrical parts (see section 3). 3) Remove the coils. 4) Detach the welded parts of the expansion valves and the pipes. 	
---	---------------------	---	--

DISASSEMBLY INSTRUCTIONS SIZE 30

No.	Part name	Procedures	Remarks
1	Panel plate	<p>How to remove the panel plate.</p> <ol style="list-style-type: none"> 1) Turn off the air conditioner. Turn off the power breaker. 2) Remove the big handle screws. 3) Remove the top cover screws and then remove the top cover (4 screws). 4) Remove the right front side panel screws, and then remove the right front side panel (1 screw). 	

DISASSEMBLY INSTRUCTIONS SIZE 30 (CONT)

5) Remove the front panel screws (8) and remove the front panel.

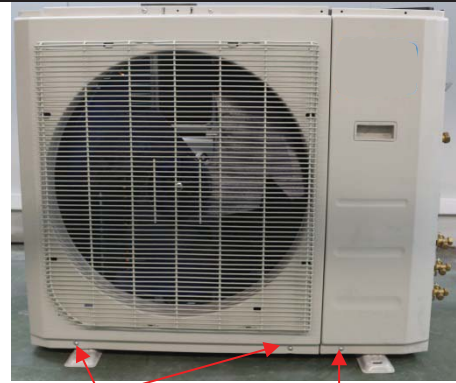

Front panel screws

Right front side panel screws

6) Remove the terminal board screws (2), the water collector screws, and the right-rear panel screws (15), and then remove the right-rear panel.



Front panel screws

Front panel screws

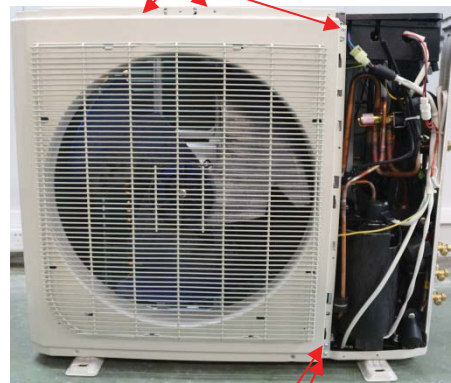

Front panel screws

DISASSEMBLY INSTRUCTIONS SIZE 30 (CONT)

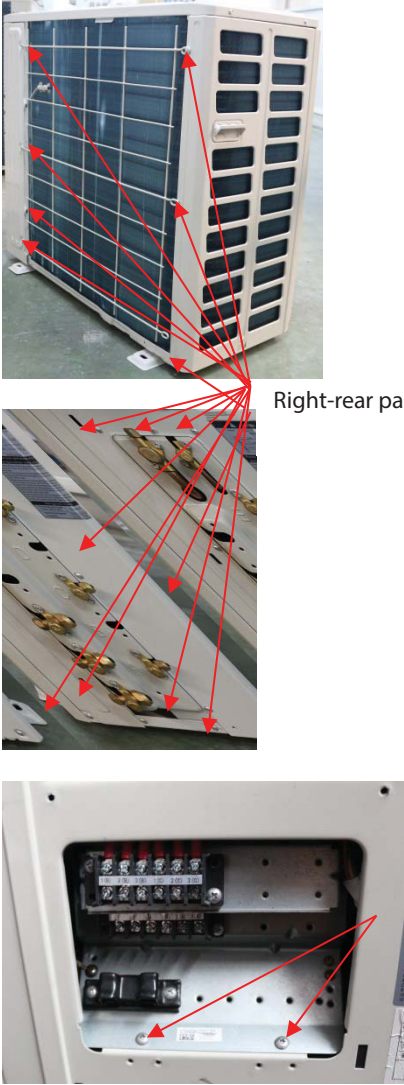
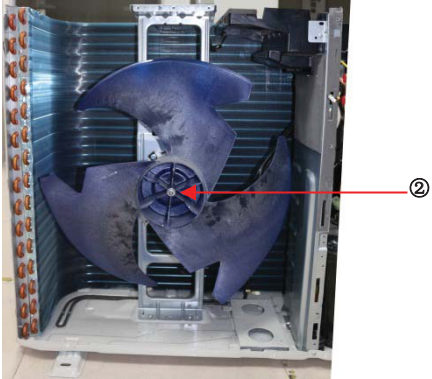
			 <p>Right-rear panel screws</p> <p>Terminal board screws</p>
2	Fan assembly	<p>How to remove the fan assembly</p> <ol style="list-style-type: none">1) Remove the top cover, right front side panel and the front panel from section 1 steps 1-4.2) Remove the hex nut securing the fan.	 <p>②</p>

DISASSEMBLY INSTRUCTIONS SIZE 30 (CONT)

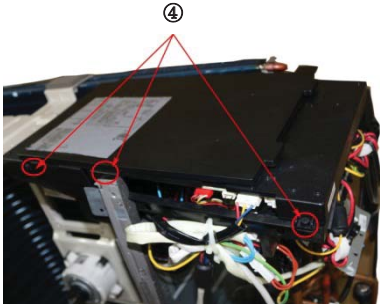
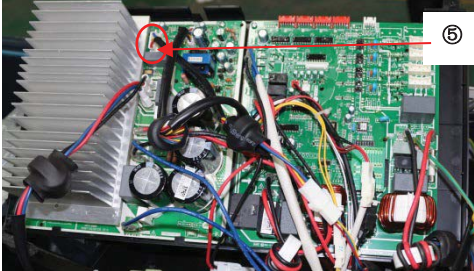
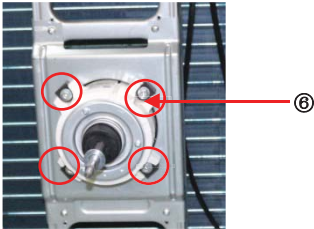
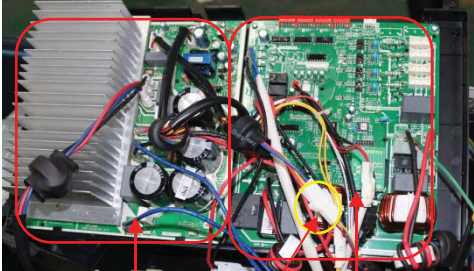
		<p>3) Remove the fan.</p> <p>4) Undo the hooks, remove the screws, and then open the electrical control box.</p> <p>5) Disconnect the fan motor connector CN19(3P, white) from the driver board.</p> <p>6) Remove the screws (4) and then remove the fan motor.</p>	  
3	Electrical parts	<p>How to remove the electrical parts.</p> <p>1) Complete steps of sections 1 and 2.</p> <p>2) Remove the connector.</p> <p>3) Remove the compressor connector.</p> <p>4) Remove the PFC inductor connector.</p>	 <p>Driver board</p> <p>PCB board</p> <p>③</p>

DISASSEMBLY INSTRUCTIONS SIZE 30 (CONT)

5) Disconnect the following three connection wires between the driver board and PCB.

- CN55-CN7(7p,white)
- CN54-CN6(red)
- CN53-CN5(black)

6) Remove the screws then remove the driver board.



7) Disconnect the connectors and wires from the PCB and other parts.

Connectors:

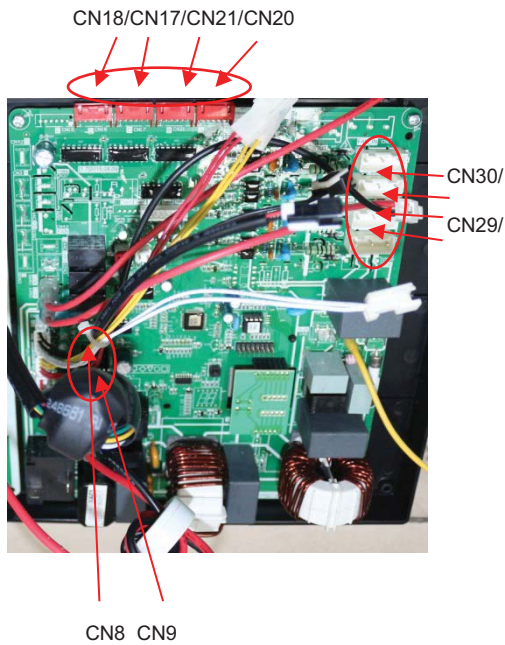
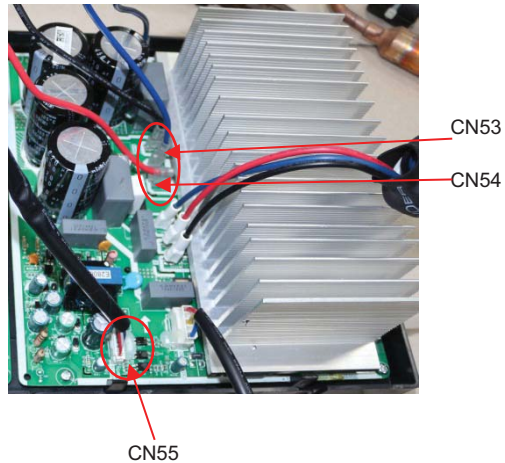
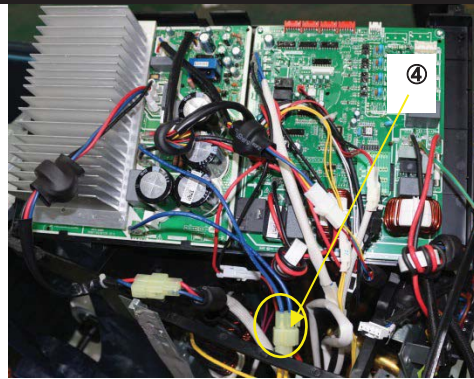
- CN8:T3/T4 temperature sensor (2p/2p,white)
- CN33: Discharge temperature sensor (2p,white)
- CN13:T2B-A,B,C,D temperature sensor (2p/2p/2p/2p,white)
- CN18/CN17/CN21/CN20: Electronic expansive valve A,B,C,D (6p/6p/6p,red/red/red)
- CN30/CN29/CN28/CN27: S-A,S-B,S-C,S-D (3p/3p/3p/3p,white)
- CN9: High and low pressure switch (2p/2p, white)

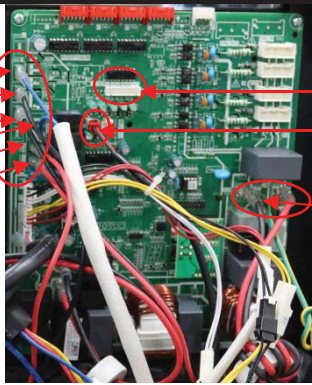
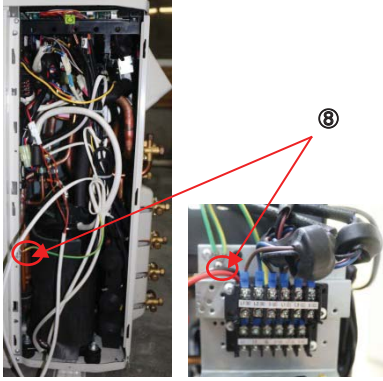

DISASSEMBLY INSTRUCTIONS SIZE 30 (CONT)

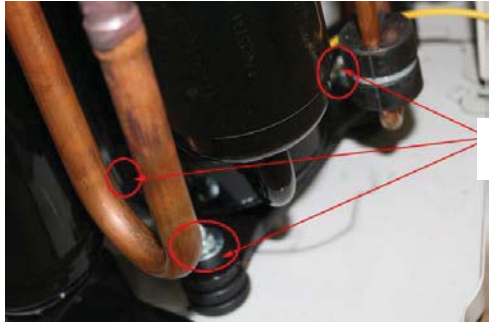
		<p>Wires:</p> <p>CN3/CN22: 4-way valve (blue-blue)</p> <p>CN4/CN40: Crankcase heating cable (black-red)</p> <p>CN10/CN44: Crankcase heating cable (black-red)</p> <p>CN1:L1-IN (red)</p> <p>CN2:L2-IN (black)</p> <p>8) Disconnect the grounding wire (yellow-green) after removing the right-rear panel.</p> <p>9) Remove the PCB board.</p>	 
4	Compressor	<p>How to remove the compressor.</p> <p>1) Complete the steps in sections 1, 2, and 3.</p> <p>2) Remove the electrical control box and the partition plate.</p> <p>3) Extract the refrigerant gas.</p> <p>4) Remove the sound insulation material and the crankcase heating cable.</p> <p>5) Remove the compressor terminal cover, disconnect the compressor thermo wires, and disconnect the compressor from the terminal.</p>	 

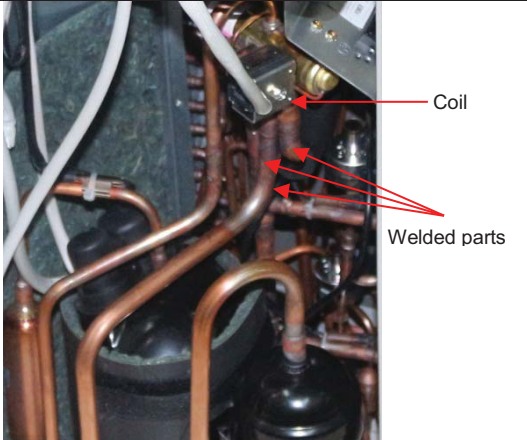
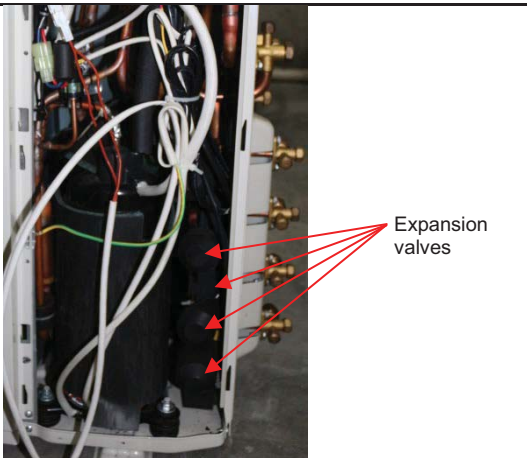

DISASSEMBLY INSTRUCTIONS SIZE 30 (CONT)

		<p>6) Remove the discharge pipe and suction pipe with a burner.</p> <p>7) Remove the hex nuts and washers securing the compressor to the bottom plate.</p> <p>8) Lift the compressor.</p>	
5	The 4-way valve	<p>How to remove the 4-way valve</p> <ol style="list-style-type: none"> 1) Perform work of item 1,2. 2) Extract the refrigerant gas. 3) Remove the electrical parts (see section 3). 4) Remove the coil screw and remove the coil. 5) Detach the welded parts of the 4-way valve and pipe. 	 <p>Coil</p> <p>Welded parts</p>
6	The expansion valve	<p>How to remove the expansion valve</p> <ol style="list-style-type: none"> 1) Complete the steps of sections 1 and 2. 2) Remove the electrical parts (see section 3). 3) Remove the coils. 4) Detach the welded parts of the expansion valves and the pipes. 	 <p>Expansion valves</p>

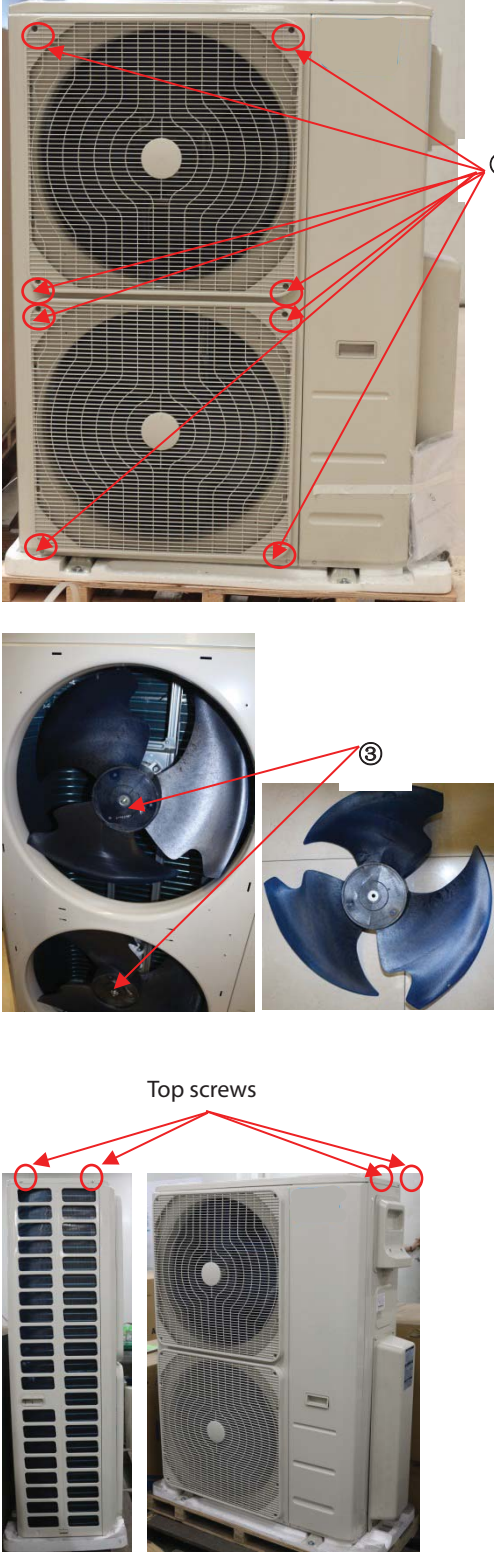
DISASSEMBLY INSTRUCTIONS SIZE 36 AND 48

No	Part name	Procedures	Remarks
1	Fan assembly	<p>How to remove the fan assembly.</p> <ol style="list-style-type: none"> 1) Turn off the air conditioner. Turn off the power breaker. 2) Remove the air outlet grille screws (8). 3) Remove the hex nut securing the fan. 4) Remove the fan. 5) Remove the top screws (4) and then remove the top cover. 	

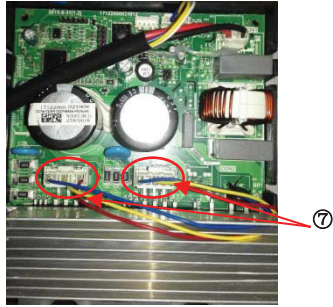
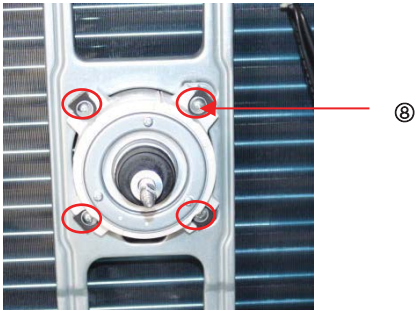
DISASSEMBLY INSTRUCTIONS SIZE 36 AND 48 (CONT)

		<p>6) Remove the front side panel screw (1), and then remove the front side panel.</p> <p>7) Disconnect the fan motor connectors FAN1(3p,white) and FAN2(3p,white) from the DC motor driver board.</p> <p>8) Remove the fan screws and remove the fan motor.</p>	  
2	Panel plate	<p>How to remove the panel plate.</p> <p>1) Remove the big handle screws (2), then remove the big handle and the water collector.</p>	

DISASSEMBLY INSTRUCTIONS SIZE 36 AND 48 (CONT)

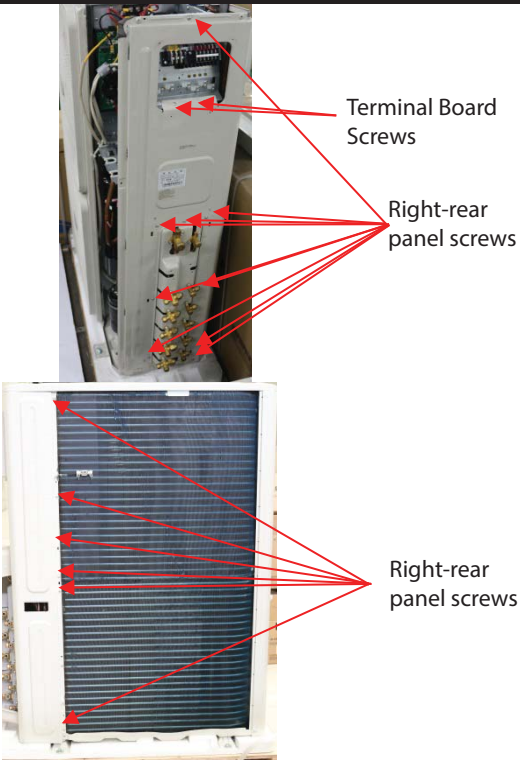
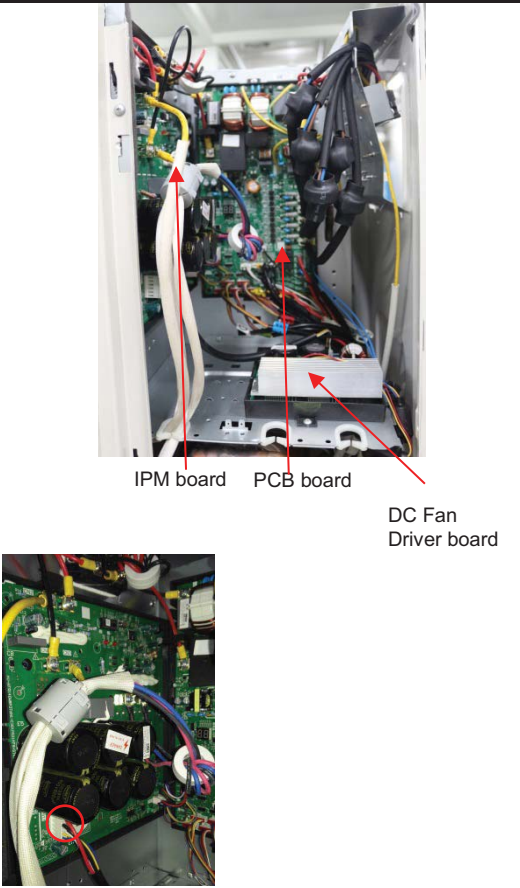
		<p>2) Remove the terminal board screws (2) and the right-rear panel screws (15) and then remove the right-rear panel.</p>	 <p>Terminal Board Screws</p> <p>Right-rear panel screws</p> <p>Right-rear panel screws</p>
3	Electrical parts	<p>How to remove the electrical parts.</p> <p>1) Complete steps 5 and 6 from section 1 and all the steps from section 2.</p> <p>2) Disconnect the fan motor connector (5p,white) from the IPM board.</p>	 <p>IPM board PCB board DC Fan Driver board</p>

DISASSEMBLY INSTRUCTIONS SIZE 36 AND 48 (CONT)

3) Disconnect the following connection wires and connectors between the IPM and the other parts.

CN2(yellow)

CN1(red)

CN6(black)

CN3(yellow)

U、V、W(black)

CN9(10p,white)

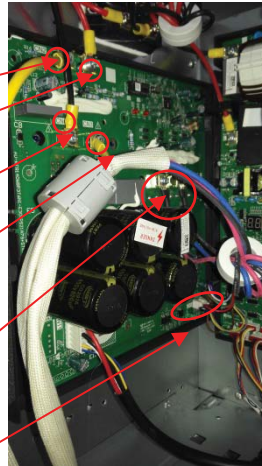

4) Remove the screws and then remove the IPM board.



5) Disconnect the connectors and wires connected from the PCB and the other parts.

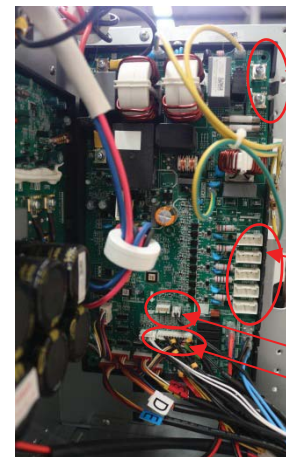

Connectors:

CN8: Discharge temperature sensor (2p,white)

CN12: Heatsink temperature sensor(2p,red)

CN9:T3/T4 temperature sensor (2p/2p,white)

CN11:T2B-A,B,C,D,E temperature sensor (2p/2p/2p/2p/2p,white)



CN15/CN23/CN26/CN30/CN33: Electronic expansive valve (6p/6p/6p/6p/6p,red)

CN3
CN1

CN13
CN16
CN21
CN29
CN37

CN8 CN12
CN9 CN11

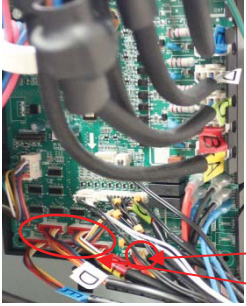
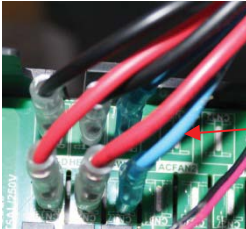
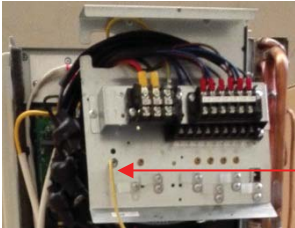
DISASSEMBLY INSTRUCTIONS SIZE 36 AND 48 (CONT)

		<p>CN37/CN29/CN21/CN16/CN13: S-A,S-B,S-C,S-D,S-E (3p/3p/3p/3p/3p,white)</p> <p>CN10: High and low pressure switch (2p/2p, white)</p> <p>Wires:</p> <p>CN17/CN18: 4-way valve (blue-blue)</p> <p>CN19/CN20: connected to crankcase heating cable. (black-red)</p> <p>CN24/CN25: Electric heater of chassis (orange-orange)</p> <p>CN1:L-IN (red)</p> <p>CN3:N-IN (black)</p> <p>6) Disconnect the grounding wire (yellow-green) after removing the big handle.</p> <p>7) Remove the PCB board.</p>	 <p>CN10</p> <p>CN30/CN23</p>  <p>CN17/CN18</p> <p>CN19/CN20</p> <p>CN24/CN25</p>  <p>⑥</p> 
4	Compressor	<p>How to remove the compressor</p> <ol style="list-style-type: none"> 1) Complete steps 5 and 6 in section 1 and all the steps in section 2. 2) Extract the refrigerant gas. 3) Remove the sound insulation material and the crankcase heating cable. 4) Remove the compressor terminal cover disconnect the crankcase electric heater wires and compressor from the terminal. 	 <p>⑤</p>

DISASSEMBLY INSTRUCTIONS SIZE 36 AND 48 (CONT)

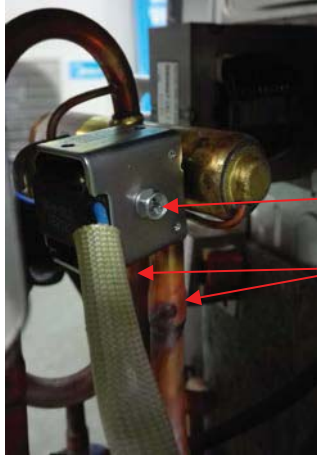
		<p>5) Remove the discharge pipe and suction pipe with a burner.</p> <p>6) Remove the hex nuts and washers securing the compressor to the bottom plate.</p> <p>7) Lift the compressor.</p>	
5	The 4-way valve	<p>How to remove the 4-way valve</p> <p>1) Complete steps 5 and 6 from section 1 and all the steps from section 2.</p> <p>2) Extract the refrigerant gas.</p> <p>3) Remove the electrical parts (see section 3)</p> <p>4) Remove the coil screw and remove the coil.</p> <p>5) Detach the welded parts of the 4-way valve and pipe.</p>	

DISASSEMBLY INSTRUCTIONS SIZE 36 AND 48 (CONT)

6	The expansion valve	<p>How to remove the expansion valve</p> <ol style="list-style-type: none">1) Complete the steps in sections 1 and 2.2) Remove the electrical parts (see section 3).3) Remove the coil.4) Detach the welded parts of the expansion valves and the pipes.	 <p>Expansion valves</p>
---	---------------------	---	--