

# OPERATION & MAINTENANCE

## *LX Series*



60HZ

OMW3-0019Y





## WARNING



**WARNING:** Before performing service or maintenance operations on the system, turn off main power switches to the unit. Electrical shock could cause serious personal injury.

**WARNING:** All WaterFurnace products are designed, tested, and manufactured to comply with the latest publicly released and available edition of UL 60335-2-40 for electrical safety certification. All field electrical connections must follow the National Electrical Code (NEC) guide standards and / or any local codes that may be applicable for the installation.

**WARNING:** Only factory authorized personnel are approved for startup, check test and commissioning of this unit.

**INSTALLER:** Please take the time to read and understand these instructions prior to any installation. Installer must give a copy of this manual to the owner.

## Definition of Warnings and Symbols

 <b>DANGER</b>	Indicates a situation that results in death or serious injury.
 <b>WARNING</b>	Indicates a situation that could result in death or serious injury.
 <b>CAUTION</b>	Indicates a situation that could result in minor or moderate injury.
<b>NOTICE</b>	Indicates a situation that could result in equipment or property damage.

## For the User



## WARNING

This appliance is not intended for use by persons (including children) with reduced physical, sensory, or mental capabilities, or lack of experience and knowledge, unless they have been given supervision or instruction concerning use of the appliance by a person responsible for their safety.

Children should be supervised to ensure that they do not play with the appliance.

Keep this manual in a safe place in order to provide your serviceman with necessary information.

## NOTICE

**NOTICE:** To avoid equipment damage, do not leave the system filled in a building without heat during cold weather, unless adequate freeze protection levels of antifreeze are used. Heat exchangers do not fully drain and will freeze unless protected, causing permanent damage.

# Table of Contents

## UNIT OVERVIEW

Nomenclatures .....	6
AHRI Data .....	7
Physical Data .....	9
Dimensional Data .....	10

## OPERATING PRINCIPLES

Electrical Data .....	12
Auxiliary Heat Ratings .....	13
Auxiliary Heat Electrical Data .....	13
Blower Performance Data .....	14
Antifreeze Corrections .....	15
Correction Factor Tables .....	16
Heat of Extraction/Heat of Rejection .....	17
Water Quality .....	18
Operating Parameters .....	19
Pressure Drop .....	20
Operation Logic Data Table .....	21
Aurora Controls Operation .....	22
Refrigerant Circuit Guideline .....	28
Electrical Information .....	29
Electronic Thermostat Installation .....	31
Electrical Information Flow Centers .....	31

## SERVICE AND TROUBLESHOOTING

Closed Loop Ground Source Systems .....	32
Open Loop Ground Water Systems .....	33
Compressor and Thermistor Resistance .....	34
Reference Calculations and Legend .....	35
Preventative Maintenance .....	36
Replacement Procedures .....	36
Troubleshooting .....	37
Aurora Interface Diagnostic (AID) Tool .....	38
Preliminary Checkout Procedure .....	38
Troubleshooting Checklist .....	39
Control Board Troubleshooting Steps .....	40
Control Board Troubleshooting Flow Charts .....	42
Communicating Thermostat Troubleshooting Guide .....	42
Control Board Signals .....	50
Jumping the Control Board .....	53
Water Side Analysis: Heat of Extraction/Rejection .....	56
Superheat/Subcooling .....	57
Troubleshooting Forms .....	59
Performance Data .....	61
Service Parts Table .....	71

<b>REVISION GUIDE</b> .....	75
-----------------------------	----

## General Installation Information

**NOTICE: Do not store or install units in corrosive environments or in locations subject to temperature or humidity extremes. Corrosive conditions and high temperature or humidity can significantly reduce performance, reliability, and service life.**

**NOTICE: A minimum of 24 in. clearance should be allowed for access to front access panel.**

**NOTICE: To avoid equipment damage, DO NOT use these units as a source of heating or cooling during the construction process. The mechanical components and filters can quickly become clogged with construction dirt and debris, which may cause system damage and void product warranty.**

### For the Installer

If you are NOT sure how to install or operate the unit, contact your dealer.

Installing and servicing air conditioning and heating equipment can be hazardous due to system pressure and electrical components. Only trained and qualified service personnel should install, repair or service heating and air conditioning equipment. When working on heating and air conditioning equipment, observe precautions in the literature, tags and labels attached to the unit and other safety precautions that may apply.

This manual contains specific information about the required qualification of the working personnel for maintenance, service and repair operations. Every working procedure that affects safety means shall only be carried out by competent persons.

Examples for such working procedures are:

- breaking into the refrigerating circuit;
- opening of sealed components or ventilated enclosures.

Follow all safety codes. Wear safety glasses and work gloves. Use quenching cloth for brazing operations. Have fire extinguisher available for all brazing operations. Follow all procedures to remain in compliance with national gas regulations.

Prior to beginning work on systems containing FLAMMABLE REFRIGERANTS, safety checks are necessary to ensure that the risk of ignition is minimized. Work shall be undertaken under a controlled procedure so as to minimise the risk of a flammable gas or vapor being present while the work is being performed. All maintenance staff and others working in the local area shall be instructed on the nature of work being carried out. Work in confined spaces shall be avoided.

The area shall be checked with an appropriate refrigerant detector prior to and during work, to ensure the technician is aware of potentially toxic or flammable atmospheres. Ensure that the leak detection equipment being used is suitable for use with all applicable refrigerants, i.e. non-sparking, adequately sealed or intrinsically safe.

If any hot work is to be conducted on the refrigerating equipment or any associated parts, appropriate fire extinguishing equipment shall be available to hand. Have a dry powder or CO2 fire extinguisher adjacent to the charging area.

No person carrying out work in relation to a REFRIGERATING SYSTEM which involves exposing any pipe work shall use any sources of ignition in such a manner that it may lead to the risk of fire or explosion. All possible ignition sources, including cigarette smoking, should be kept sufficiently far away from the site of installation, repairing, removing and disposal, during which refrigerant can possibly be released to the surrounding space. Prior to work taking place, the area around the equipment is to be surveyed to make sure that there are no flammable hazards or ignition risks. "No Smoking" signs shall be displayed.

Where electrical components are being changed, they shall be fit for the purpose and to the correct specification. At all times the manufacturer's maintenance and service guidelines shall be followed. If in doubt, consult the manufacturer's technical department for assistance.

The following checks shall be applied to installations using FLAMMABLE REFRIGERANTS:

- the actual REFRIGERANT CHARGE is in accordance with the room size within which the refrigerant containing parts are installed;
- the ventilation machinery and outlets are operating adequately and are not obstructed;
- if an indirect refrigerating circuit is being used, the secondary circuit shall be checked for the presence of refrigerant;
- marking to the equipment continues to be visible and legible. Markings and signs that are illegible shall be corrected;
- refrigerating pipe or components are installed in a position where they are unlikely to be exposed to any substance which may corrode refrigerant containing components, unless the components are constructed of materials which are inherently resistant to being corroded or are suitably protected against being so corroded.

### Instructions for Equipment Using R-454B Refrigerant

#### WARNING

- **Do NOT pierce or burn**
- **Do NOT use means to accelerate the defrosting process or to clean the equipment, other than those recommended by the manufacturer**
- **Be aware that refrigerants may not contain an odor**

#### WARNING

- **The Appliance should be stored so as to prevent mechanical damage and in a room without continuously operating ignition sources (example: open flames, an operating gas appliance or an operating electric heater)**

## General Installation Information

### WARNING

**Ventilated Area:** ensure that the area is in the open or that it is adequately ventilated before breaking into the system of conducting any hot work. A degree of ventilation should continue during the period that the work is carried out. The ventilation should safely disperse any released refrigerant and preferably expel it. Keep ventilation area clear of obstructions!

### WARNING

Do NOT use potential sources of ignition in searching for or detection of refrigerant leaks. A halide torch (or any other detector using a naked flame) shall not be used.

The following leak detection methods are deemed acceptable for all refrigerant systems. Electronic leak detectors may be used to detect refrigerant leaks but, in the case of FLAMMABLE REFRIGERANTS, the sensitivity may not be adequate, or may need re-calibration. (Detection equipment shall be calibrated in a refrigerant-free area.) Ensure that the detector is not a potential source of ignition and is suitable for the refrigerant used. Leak detection equipment shall be set at a percentage of the LFL of the refrigerant and shall be calibrated to the refrigerant employed, and the appropriate percentage of gas (25 % maximum) is confirmed. Leak detection fluids are also suitable for use with most refrigerants but the use of detergents containing chlorine shall be avoided as the chlorine may react with the refrigerant and corrode the copper pipe-work. NOTE Examples of leak detection fluids are bubble method, fluorescent method agents. If a leak is suspected, all naked flames shall be removed/extinguished. If a leakage of refrigerant is found which requires brazing, all of the refrigerant shall be recovered from the system, or isolated (by means of shut off valves) in a part of the system remote from the leak. Removal of refrigerant shall follow the procedure outlined in this manual.

## Installation Site

This equipment has been evaluated to be installed up to a maximum altitude of 3000m (9843ft) and should not be installed at an altitude greater than 3000m. For installation only in locations not accessible to the general public.

### WARNING

For appliances using A2L refrigerants connected via an air duct system to one or more rooms, only auxiliary devices approved by the appliance manufacturer or declared suitable with the refrigerant shall be installed in connecting ductwork. The manufacturer shall list in the instructions all approved auxiliary devices by manufacturer and model number for use with the specific appliance, if those devices have a potential to become an ignition source.

## Installation Space Requirements

**NOTE:** Equipment with refrigerant charge less than 62 oz does not require have a minimum floor area requirement and does not require a refrigerant leak detection sensor. The sensor might be added as a feature.

### WARNING

Equipment containing R-454B refrigerant shall be installed, operated, and stored in a room with floor area larger than the area defined in the "Minimum Floor Area" chart based on the total refrigerant charge in the system. This requirement applies to indoor equipment with or without a factory refrigerant leakage sensor.

### CAUTION

It is not recommended to use a potable water source for this equipment water supply.

### WARNING

This equipment comes with a factory installed Refrigerant Detection Device which is capable of determining it's specified end-of-life and replacement instructions. Refrigerant sensors for refrigerant detection systems shall only be replaced with sensors specified by the appliance manufacture.

### WARNING

Take sufficient precautions in case of refrigerant leakage. If refrigerant gas leaks, ventilate the area immediately.

**POSSIBLE RISKS:** Excessive refrigerant concentrations in a closed room can lead to oxygen deficiency

### WARNING

ALWAYS recover the refrigerant. Do NOT release them directly into the environment. Follow handling instructions carefully in compliance with national regulations.

### WARNING

Check that cabling will not be subject to wear, corrosion, excessive pressure, vibration, sharp edges or any other adverse environmental effects. The check shall also take into account the effects of aging or continual vibration from sources such as compressors or fans.

# Nomenclature

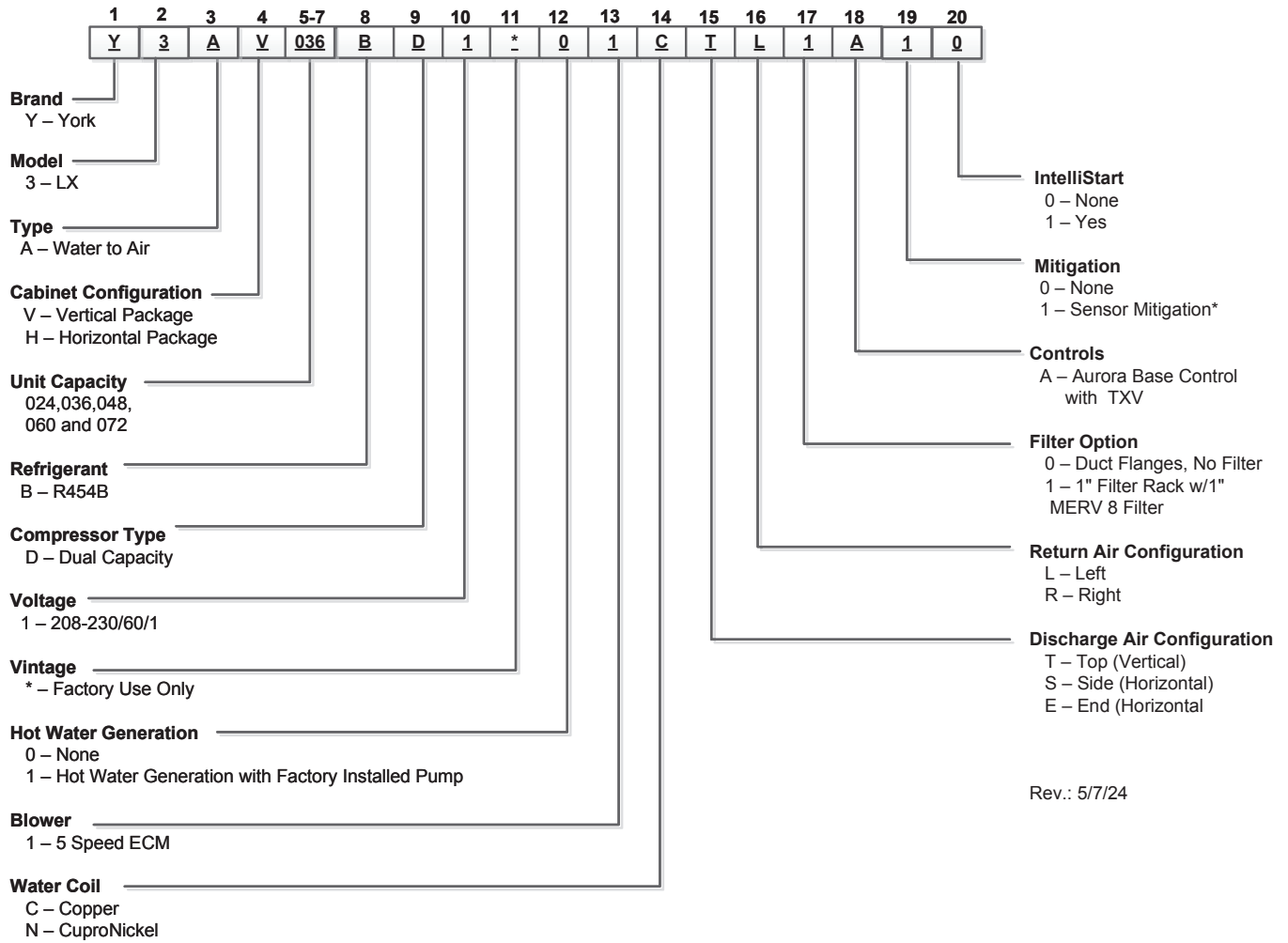

Rev.: 5/7/24

\* Sensor mitigation required on 072 models. Not available on 024-060 models.

## AHRI Data

The performance standard AHRI/ASHRAE/ISO 13256-1 became effective January 1, 2000 and replaces ARI Standards 320, 325, and 330. This new standard has three major categories: Water Loop (comparable to ARI 320), Ground Water (ARI 325), and Ground Loop (ARI 330). Although these standards are similar there are some differences:

### Unit of Measure: The Cooling COP

The cooling efficiency is measured in EER (US version measured in Btu/h per Watt. The Metric version is measured in a cooling COP (Watt per Watt) similar to the traditional COP measurement.

### Water Conditions Differences

Entering water temperatures have changed to reflect the centigrade temperature scale. For instance the water loop heating test is performed with 68°F (20°C) water rounded down from the old 70°F (21.1°C).

### Air Conditions Differences

Entering air temperatures have also changed (rounded down) to reflect the centigrade temperature scale. For instance the cooling tests are performed with 80.6°F (27°C) dry bulb and 66.2°F (19°C) wet bulb entering air instead of the traditional 80°F (26.7°C) DB and 67°F (19.4°C) WB entering air temperatures. 80.6/66.2 data may be converted to 80/67 using the entering air correction table. This represents a significantly lower relative humidity than the old 80/67 of 50% and will result in lower latent capacities.

### Pump Power Correction Calculation

Within each model, only one water flow rate is specified for all three groups and pumping Watts are calculated using the following formula. This additional power is added onto the existing power consumption.

- Pump power correction = (gpm x 0.0631) x (Press Drop x 2990) / 300

Where 'gpm' is waterflow in gpm and 'Press Drop' is the pressure drop through the unit heat exchanger at rated water flow in feet of head.

### Blower Power Correction Calculation

Blower power is corrected to zero external static pressure using the following equation. The nominal airflow is rated at a specific external static pressure. This effectively reduces the power consumption of the unit and increases cooling capacity but decreases heating capacity. These Watts are significant enough in most cases to increase EER and COPs fairly dramatically over ARI 320, 325, and 330 ratings.

- Blower Power Correction = (cfm x 0.472) x (esp x 249) / 300

Where 'cfm' is airflow in cfm and 'esp' is the external static pressure at rated airflow in inches of water gauge.

### ISO Capacity and Efficiency Calculations

The following equations illustrate cooling calculations:

- ISO Cooling Capacity = Cooling Capacity (Btu/h) + (Blower Power Correction (Watts) x 3.412)
- ISO EER Efficiency (W/W) = ISO Cooling Capacity (Btu/h) x 3.412 / [Power Input (Watts) - Blower Power Correction (Watts) + Pump Power Correction (Watt)]

The following equations illustrate heating calculations:

- ISO Heating Capacity = Heating Capacity (Btu/h) - (Blower Power Correction (Watts) x 3.412)
- ISO COP Efficiency (W/W) = ISO Heating Capacity (Btu/h) x 3.412 / [Power Input (Watts) - Blower Power Correction (Watts) + Pump Power Correction (Watt)]

### Comparison of Test Conditions

	ARI 320	ISO/AHRI 13256-1 WLHP	ARI 325	ISO/AHRI 13256-1 GWHP	ARI 330	ISO/AHRI 13256-1 GLHP
<b>Cooling</b>						
Entering Air - DB/WB °F	80/67	80.6/66.2	80/67	80.6/66.2	80/67	80.6/66.2
Entering Water - °F	85	86	50/70	59	77	77
Fluid Flow Rate	*	**	**	**	**	**
<b>Heating</b>						
Entering Air - DB/WB °F	70	68	70	68	70	68
Entering Water - °F	70	68	50/70	50	32	32
Fluid Flow Rate	*	**	**	**	**	**

**NOTES:** \* Flow rate is set by 10°F rise in standard cooling test

\*\* Flow rate is specified by the manufacturer

Part load entering water conditions not shown

WLHP = Water Loop Heat Pump; GWHP = Ground Water Heat Pump; GLHP = Ground Loop Heat Pump

### Conversions:

Airflow (lps) = cfm x 0.472;

WaterFlow (lps) = gpm x 0.0631;

ESP (Pascals) = ESP (in wg) x 249;

Press Drop (Pascals) = Press Drop (ft hd) x 2990

## AHRI Data cont.

Model	Flow Rate		Ground Water Heat Pump				Ground Loop Heat Pump			
			Cooling		Heating		Cooling Brine		Heating Brine	
	gpm	cfm	Capacity Btuh	EER Btuh/W	Capacity Btuh	COP	Capacity Btuh	EER Btuh/W	Capacity Btuh	COP
024	8	800	25,700	21.30	23,000	4.60	23,200	15.70	19,000	4.00
	7	600	18,600	25.30	16,700	4.70	17,900	21.30	15,400	4.30
036	9	1200	37,500	20.50	35,400	4.30	35,600	15.80	26,800	3.70
	8	1000	28,700	26.40	25,300	4.60	28,000	22.40	22,000	4.20
048	12	1600	51,200	19.60	46,000	4.20	49,000	16.00	37,300	3.70
	11	1400	38,000	24.50	33,500	4.50	36,700	21.00	29,900	4.10
060	16	1800	63,000	18.80	55,800	4.00	59,500	15.20	45,800	3.40
	14	1500	46,100	23.50	38,200	4.20	45,200	20.40	34,900	3.90
072	18	1900	69,500	20.80	68,900	4.20	65,800	16.40	53,000	3.60
	16	1550	53,300	23.90	52,100	4.30	51,600	20.40	43,400	3.90

Cooling capacities based upon 80.6°F DB, 66.2°F WB entering air temperature

5/6/24

Heating capacities based upon 68°F DB, 59°F WB entering air temperature  
All ratings based upon 208V operation

### Energy Star Compliance Table

Model	Tier 3	
	Ground Water	Ground Loop
024	Yes	Yes
036	Yes	Yes
048	Yes	Yes
060	Yes	Yes
072	Yes	Yes

4/2/24

### Energy Star Rating Criteria

In order for water-source heat pumps to be Energy Star rated they must meet or exceed the minimum efficiency requirements listed below. Tier 3 represents the current minimum efficiency water source heat pumps must have in order to be Energy Star rated.

#### Tier 3: 1/1/2012 - No Effective End Date Published

Water-to-Air	EER	COP
Ground Loop	17.1	3.6
Ground Water	21.1	4.1
Water-to-Water		
Ground Loop	16.1	3.1
Ground Water	20.1	3.5

## Physical Data

Model		Dual Capacity				
		024	036	048	060	072
Compressor (1 each)		Copeland Ultra Tech, Dual Capacity Scroll				
Factory Charge R-454B, oz [kg]	Vertical	32 [0.91]	44 [1.25]	58 [1.64]	62 [1.76]	*76 [2.15]
Factory Charge R-454B, oz [kg]	Horizontal	32 [0.91]	42 [1.19]	58 [1.64]	60 [1.70]	*73 [2.07]
<b>ECM Blower Motor &amp; Blower</b>						
Blower Motor Type/Speeds	ECM	5 Speed ECM				
Blower Motor- hp [W]	ECM	1/2 [373]	1/2 [373]	1 [746]	1 [746]	1 [746]
Blower Wheel Size (Dia x W), in. [mm]	ECM	9 x 7 [229 x 178]	9 x 7 [229 x 178]	11 x 10 [279 x 254]	11 x 10 [279 x 254]	11 x 10 [279 x 254]
<b>Coax and Water Piping</b>						
Water Connections Size - Swivel - in [mm]		1" [25.4]	1" [25.4]	1" [25.4]	1" [25.4]	1" [25.4]
HWG Connection Size - Stub - in [mm]		1/2" [12.7]	1/2" [12.7]	1/2" [12.7]	1/2" [12.7]	1/2" [12.7]
Coax & Piping Water Volume - gal [l]		.35 [1.3]	.7 [2.6]	.7 [2.6]	1.3 [4.9]	1.6 [6.1]
<b>Vertical</b>						
Air Coil Dimensions (H x W), in. [mm]		19 x 20 [483 x 508]	24 x 20 [610 x 508]	28 x 25 [711 x 635]	28 x 25 [711 x 635]	32 x 25 [813 x 635]
Air Coil Total Face Area, ft <sup>2</sup> [m <sup>2</sup> ]		2.6 [0.245]	3.3 [0.310]	4.9 [0.452]	4.9 [0.452]	5.6 [0.516]
Air Coil Tube Size, in [mm]		3/8 [9.5]	3/8 [9.5]	3/8 [9.5]	3/8 [9.5]	3/8 [9.5]
Air Coil Number of rows		3	3	3	3	3
Optional Filter - 1" [25mm] Pleated MERV8 Throwaway, in [mm]		20 x 24 [508 x 610]	20 x 24 [508 x 610]	28 x 30 [711 x 762]	28 x 30 [711 x 762]	30 x 32 [762 x 813]
Weight - Operating, lb [kg]		198 [90]	221 [100]	303 [137]	329 [149]	350 [159]
Weight - Packaged, lb [kg]		218 [99]	241 [109]	323 [147]	349 [158]	370 [168]
<b>Horizontal</b>						
Air Coil Dimensions (H x W), in. [mm]		18 x 21 [457 x 533]	18 x 27 [457 x 686]	20 x 35 [508 x 889]	20 x 35 [508 x 889]	20 x 40 [508 x 1016]
Air Coil Total Face Area, ft <sup>2</sup> [m <sup>2</sup> ]		2.6 [0.244]	3.4 [0.314]	4.9 [0.452]	4.9 [0.452]	5.6 [0.516]
Air Coil Tube Size, in [mm]		3/8 [9.5]	3/8 [9.5]	3/8 [9.5]	3/8 [9.5]	3/8 [9.5]
Air Coil Number of rows		3	3	3	3	3
Optional Filter - 1" [25mm] Pleated MERV8 Throwaway, in [mm]		1 - 18 x 24 [457 x 610]	1 - 20 x 32 [508 x 813]	1 - 20 x 37 [508 x 940]	1 - 20 x 37 [508 x 940]	1 - 20 x 20 [508 x 508] 1 - 20 x 22 [508 x 559]
Weight - Operating, lb [kg]		228 [103]	250 [113]	325 [147]	358 [162]	369 [167]
Weight - Packaged, lb [kg]		248 [112]	270 [122]	345 [156]	378 [171]	389 [176]

4/1/24

\* Note: Units require refrigerant mitigation.

# Vertical Dimensional Data

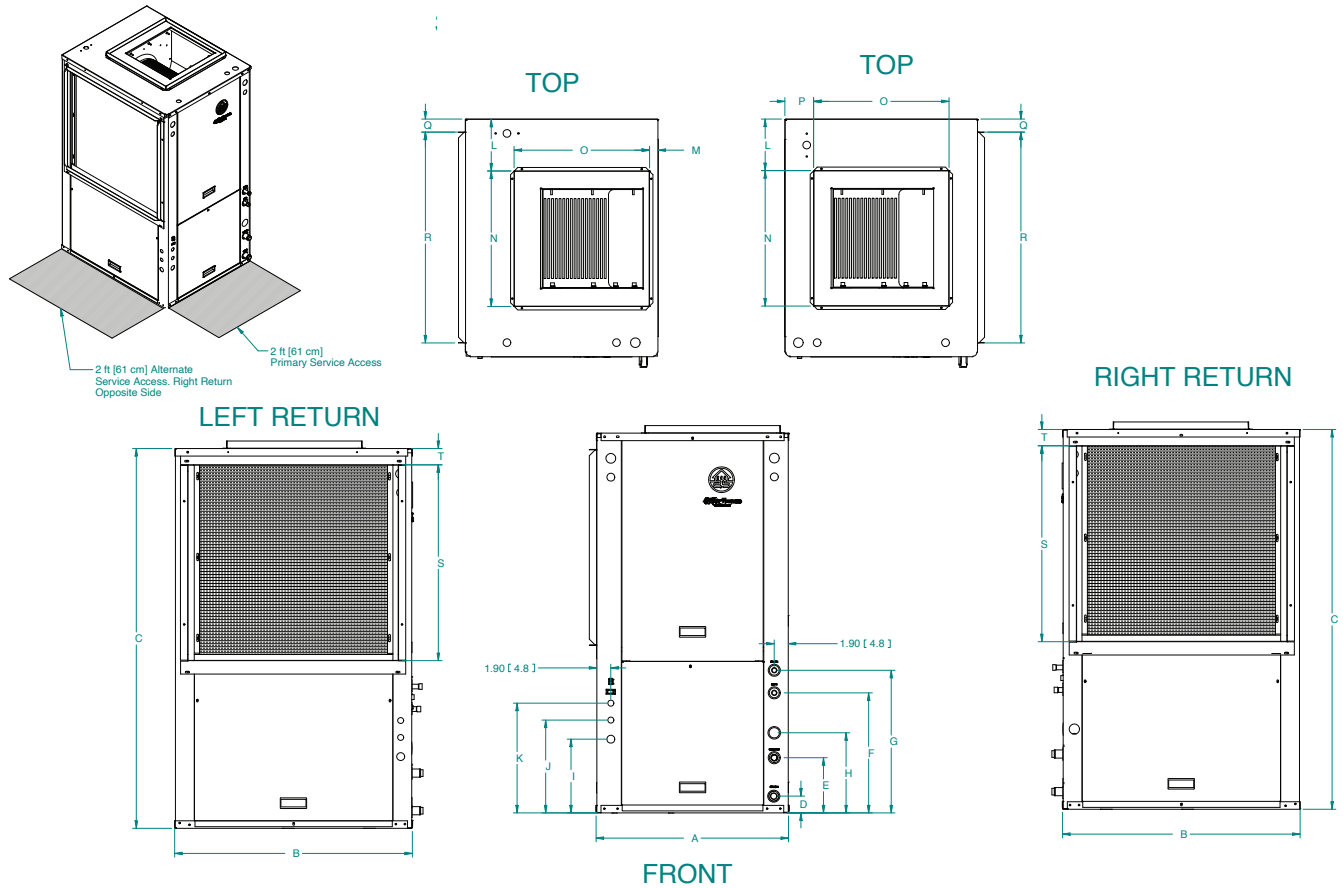

Vertical Top Flow Model	Overall Cabinet			Water Connections						Electrical Connections			Discharge Connection duct flange installed ( $\pm 0.10$ in)					Return Connection Return Duct Flanges					
	A	B	C	D	E	F	G	H	Loop Water FPT	HWG (O.D.)	I 3/4" cond	J 1/2" cond	K 1/2" cond	L	M	N	O	P	Q	R	S	T	
	Width	Depth	Height	Loop In	Loop Out	HWG In	HWG Out	Condensate			Power Supply	Ext Pump	Low Voltage	Supply Width	Supply Depth	Return Depth	Return Height						
024	in.	22.5	26.5	39.4	2.3	5.3	13.4	16.4	9.6	1" Swivel	1/2" Stub	8.9	11.4	13.7	6.3	0.7	14.0	14.0	2.7	2.3	22.0	18.0	1.8
	cm.	57.2	67.3	100.1	5.8	13.5	34.0	41.7	24.4			22.6	29.0	34.8	16.0	1.8	35.6	35.6	6.9	5.8	55.9	45.7	4.6
036	in.	22.5	26.5	44.5	2.0	7.0	13.5	16.5	10.2	1" Swivel	1/2" Stub	9.5	12.1	14.3	6.1	0.8	14.0	14.0	4.4	2.4	22.0	22.0	2.0
	cm.	57.2	67.3	113.0	5.1	17.8	34.3	41.9	25.9			24.1	30.7	36.3	15.5	2.0	35.6	35.6	11.2	6.1	55.9	55.9	5.1
048-060	in.	25.6	31.6	50.4	2.3	7.3	15.9	18.9	10.6	1" Swivel	1/2" Stub	9.8	12.3	14.6	6.9	1.1	18.0	18.0	3.8	1.7	28.0	26.0	1.7
	cm.	65.0	80.3	128.0	5.8	18.5	40.4	48.0	26.9			24.9	31.2	37.1	17.5	2.8	45.7	45.7	9.7	4.3	71.1	66.0	4.3
072	in.	25.6	31.6	54.4	2.3	7.3	15.9	18.9	10.6	1" Swivel	1/2" Stub	9.8	12.3	14.6	6.9	1.1	18.0	18.0	3.8	1.7	28.1	30.0	2.2
	cm.	65.0	80.3	138.2	5.8	18.5	40.4	48.0	26.9			24.9	31.2	37.1	17.5	2.8	45.7	45.7	9.7	4.3	71.4	76.2	5.6

Condensate is 3/4" PVC female glue socket and is switchable from side to front

7/17/14

Unit shipped with 1" [25.4mm] return duct flanges and are suitable for duct connection.

The optional 1" filter rack (not shown) has the same return opening connection size as the duct flanges shown in the drawing. The filter rack extends 2.25"(57.1 mm) from the unit.

The optional 1" filter rack is suitable for duct connection.

The optional filter rails (not shown) extend 1.25" (31.75 mm) from cabinet.

# Horizontal Dimensional Data

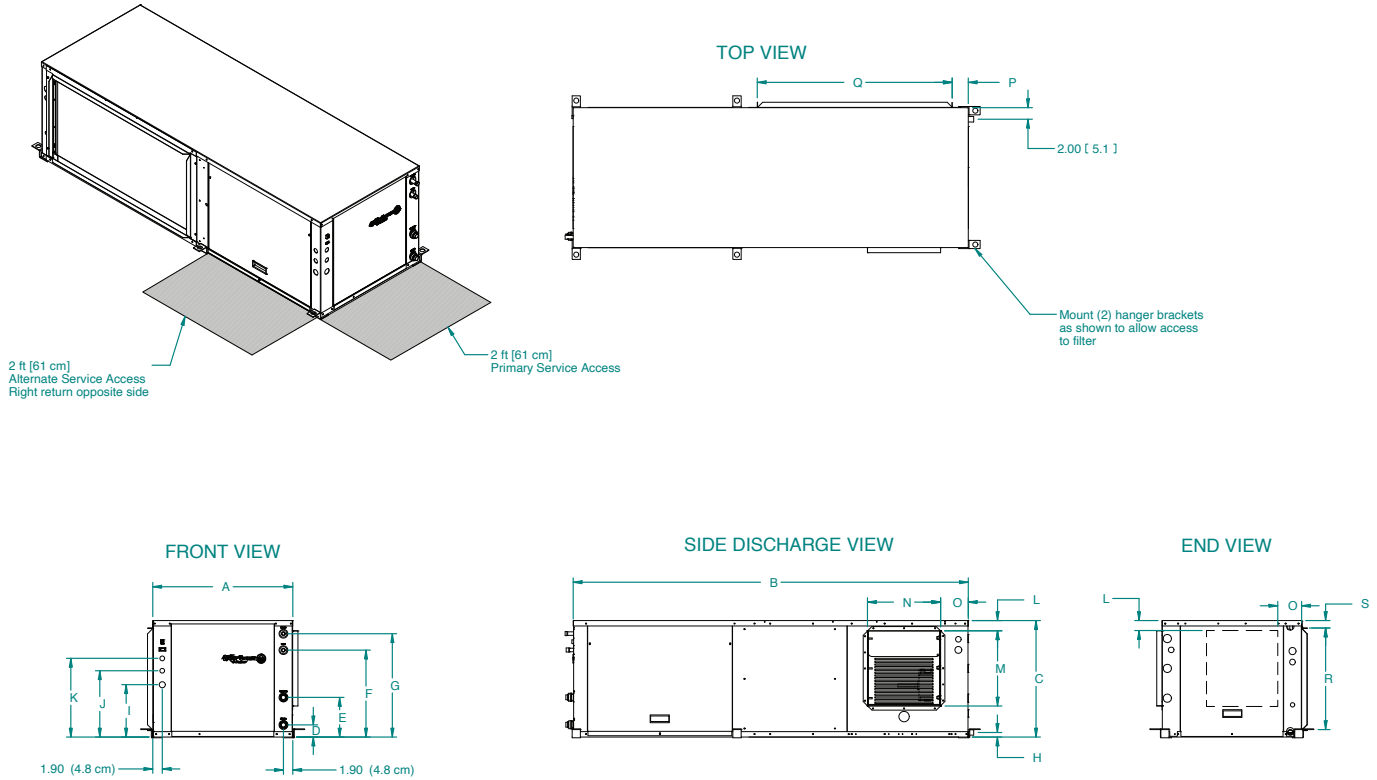

Horizontal Model	Overall Cabinet			Water Connections							Electrical Connections			Discharge Connection Duct Flange Installed				Return Connection Return Duct Flanges				
	A	B	C	D	E	F	G	H	Loop Water FPT	HWG (O.D.)	I	J	K	L*	M	N	O*	P	Q	R	S	
	Width	Depth	Height	In	Out	HWG In	HWG Out	Condensate			3/4" cond	1/2" cond	1/2" cond									Supply Height
	in.	cm.	in.	cm.	in.	cm.	in.	cm.	in.	cm.	in.	cm.	in.	cm.	in.	cm.	in.	cm.	in.	cm.	in.	cm.
024	in.	22.5	53.0	19.3	2.3	5.3	13.8	16.8	0.8	1" Swivel	1/2" Stub	8.9	11.5	13.7	1.7	10.5	9.5	8.2	2.2	21.8	16.5	1.5
	cm.	57.2	134.6	49.0	5.8	13.5	35.1	42.7	2.0		Stub	22.6	29.2	34.8	4.3	26.7	24.1	20.8	5.6	55.4	41.9	3.8
036	in.	22.5	63.0	19.3	2.3	7.3	13.5	16.5	0.8	1" Swivel	1/2" Stub	9.5	12.1	14.3	2.3	10.5	9.5	5.7	2.8	30.5	16.7	1.3
	cm.	57.2	160.0	49.0	5.8	18.5	34.3	41.9	2.0		Stub	24.1	30.7	36.3	5.8	26.7	24.1	14.5	7.1	77.5	42.4	3.3
048-060	in.	25.6	72.0	21.3	2.3	7.3	15.9	18.9	0.8	1" Swivel	1/2" Stub	9.5	12.1	14.3	1.9	13.6	13.2	5.0	2.9	35.5	18.6	1.3
	cm.	65.0	182.9	54.1	5.8	18.5	40.4	48.0	2.0		Stub	24.1	30.7	36.3	4.8	34.5	33.5	12.7	7.4	90.2	47.2	3.3
072	in.	25.6	77.0	21.3	2.3	7.3	15.9	18.9	0.8	1" Swivel	1/2" Stub	9.5	12.1	14.3	1.9	13.6	13.2	5.0	2.8	40.4	18.7	1.5
	cm.	65.0	195.6	54.1	5.8	18.5	40.4	48.0	2.0		Stub	24.1	30.7	36.3	4.8	34.5	33.5	12.7	7.1	102.6	47.5	3.8

\* Dimensions shown are for left return side discharge other configurations shown in tables below

7/18/14

Condensate is 3/4" PVC female glue socket and is switchable from side to front

Water connections extend 1.2" [30.5mm] beyond front of cabinet.

The optional 1" filter rack (not shown) has the same return opening connection size as the duct flanges shown in the drawing. The filter rack extends 2.25" (57.1 mm) from the unit.

The optional 1" filter rack is suitable for duct connection.

The optional filter rails (not shown) extend 1.25" (31.75 mm) from cabinet.

The O24 model is not field convertible changing from end to side discharge. It requires an additional discharge panel (not supplied).

024 Model		L	O
Right Return End Discharge	in	2.2	5.7
	cm	5.6	14.5
Right Return Side Discharge	in	6.9	8.3
	cm	17.5	21.1
Left Return End Discharge	in	6.5	7.3
	cm	16.5	18.5

036 Model		L	O
Right Return End Discharge	in	6.5	6.6
	cm	16.5	16.8
Right Return Side Discharge	in	2.3	5.7
	cm	5.8	14.5
Left Return End Discharge	in	6.5	6.6
	cm	16.5	16.8

048-060 Models		L	O
Right Return End Discharge	in	1.9	5.0
	cm	4.8	12.7
Right Return Side Discharge	in	5.7	5.0
	cm	14.5	12.7
Left Return End Discharge	in	5.7	4.9
	cm	14.5	12.4

072 Model		L	O
Right Return End Discharge	in	1.9	5.0
	cm	4.8	12.7
Right Return Side Discharge	in	5.7	5.0
	cm	14.5	12.7
Left Return End Discharge	in	5.7	5.0
	cm	14.5	12.7

## Electrical Data

### Dual Capacity with ECM motor

Model	Rated Voltage	Voltage Min/Max	Compressor				HWG Pump FLA	Ext Loop FLA	Blower Motor FLA	Total Unit FLA	Min Circ Amp	Max Fuse/HACR
			MCC	RLA	LRA	LRA*						
<b>024</b>	208-230/60/1	187/253	16.0	10.2	62.0	21.7	0.4	5.4	4.1	20.1	22.7	35
<b>036</b>	208-230/60/1	187/253	22.7	14.5	90.0	32.4	0.4	5.4	4.1	24.4	28.1	40
<b>048</b>	208-230/60/1	187/253	28.6	18.3	138.0	49.7	0.4	5.4	7.6	31.7	36.3	50
<b>060</b>	208-230/60/1	187/253	39.3	25.2	147.3	51.5	0.4	5.4	7.6	38.6	44.8	70
<b>072</b>	208-230/60/1	187/253	43.7	28.0	160.0	56.0	0.4	5.4	7.6	41.4	48.4	70

\*With optional IntelliStart

6/25/24

Rated Voltage of 208/230/60/1  
 HACR circuit breaker in USA only  
 All fuses Class RK-5

## Auxiliary Heat Ratings

Model	KW		Stages	BTU/HR		Min CFM	Compatibility		
	208V	230V		208V	230V		024	036	048 - 072
EAM(H)5	3.6	4.8	1	12,300	16,300	450	•	•	
EAM(H)8	5.7	7.6	2	19,400	25,900	550	•	•	
EAM(H)10	7.2	9.6	2	24,600	32,700	650	•	•	
EAL(H)10	7.2	9.6	2	24,600	32,700	1100			•
EAL(H)15	10.8	14.4	2	36,900	49,100	1250			•
EAL(H)20	14.4	19.2	2	49,200	65,500	1500			•

4/2/24

Order the "H" part number when installed on horizontal and vertical rear discharge units

Air flow level for auxiliary heat (Aux) must be equal to or above the minimum CFM in this table

## Auxiliary Heat Electrical Data

Model	Supply Circuit	Heater Amps		Min Circuit Amp		Fuse (USA)		Fuse (CAN)		CKT BRK	
		208 V	240 V	208 V	240 V	208 V	240 V	208 V	240 V	208 V	240 V
EAM(H)5	Single	17.3	20.0	26.7	30.0	30	30	30	30	30	30
EAM(H)8	Single	27.5	31.7	39.3	44.6	40	45	40	45	40	45
EAM(H)10	Single	34.7	40.0	48.3	55.0	50	60	50	60	50	60
EAL(H)10	Single	34.7	40.0	53.3	60.0	60	60	60	60	60	60
EAL(H)15	Single	52.0	60.0	75.0	85.0	80	90	80	90	70	100
	L1/L2	34.7	40.0	53.3	60.0	60	60	60	60	60	60
	L3/L4	17.3	20.0	21.7	25.0	25	25	25	25	20	30
EAL(H)20	Single	69.3	80.0	96.7	110.0	100	110	100	110	100	100
	L1/L2	34.7	40.0	53.3	60.0	60	60	60	60	60	60
	L3/L4	34.7	40.0	43.3	50.0	45	50	45	50	40	50

All heaters rated single phase 60 cycle and include unit fan load

All fuses type "D" time delay (or HACR circuit breaker in USA)

Supply wire size to be determined by local codes

4/2/24

# Blower Performance Data

## 5-Speed ECM Constant Torque Motors

The 5-Speed ECM is a 'Constant Torque' ECM motor and delivers air flow similar to a PSC but operates as efficiently as an ECM Motor. Because it's an ECM Motor, the 5-Speed ECM can ramp slowly up or down like the ECM motor. There are 5 possible speed taps available on the 5-Speed ECM motor with #1 being the lowest airflow and #5 being the highest airflow. These speed selections are preset at the time of manufacture and are easily changed in the field if necessary.

If more than one tap are energized at the same time, built in logic gives precedence to the highest tap number and allows air flow to change with G, Y1, Y2 and W signals or with Fan, CC, CC2, and E1 output signals. Each of those 5 speeds has a specific 'Torque' value programmed into the motor for

each speed selection. As static pressure increases, airflow decreases resulting in less torque on the rotor. The motor responds only to changes in torque and adjusts its speed accordingly.

The 5-Speed ECM motor is powered by line voltage but the motor speed is energized by 24 VAC.

### 5-Speed ECM Benefits:

- High efficiency
- Soft start
- 5 speeds with up to 4 speeds on-line
- Built in logic allows air flow to change with G, Y1, Y2 and W signals
- Super efficient low airflow continuous blower setting (G)

## Dual Capacity with 5-Speed ECM

Model	Motor Speed	Motor Tap	T'stat Cnct.	Blower Size	Motor HP	Airflow (cfm) at External Static Pressure (in. wg)															
						0	0.05	0.1	0.15	0.2	0.25	0.3	0.35	0.4	0.45	0.5	0.6	0.7	0.8	0.9	1.00
024	<b>High</b>	<b>5</b>	W	9 x 7	1/2	1024	1013	1002	988	974	963	951	940	929	901	872	785	691	-	-	-
	<b>Med High</b>	<b>4</b>	Y2			932	917	902	892	882	867	851	842	832	817	802	756	661	-	-	-
	Med	3				835	826	816	801	785	772	759	749	738	719	700	677	636	-	-	-
	<b>Med Low</b>	<b>2</b>	Y1			765	747	729	720	710	696	681	662	643	627	611	581	515	-	-	-
	<b>Low</b>	<b>1</b>	G			665	656	647	626	605	593	580	561	541	519	496	443	392	-	-	-
036	<b>High</b>	<b>5</b>	W	9 x 7	1/2	1325	1319	1313	1293	1272	1242	1212	1158	1103	1058	1013	930	839	-	-	-
	<b>Med High</b>	<b>4</b>	Y2			1279	1267	1254	1238	1222	1203	1184	1137	1089	1049	1008	926	836	-	-	-
	Med	3				1229	1218	1206	1187	1167	1154	1140	1110	1079	1044	1008	929	829	-	-	-
	<b>Med Low</b>	<b>2</b>	Y1			1201	1184	1167	1156	1145	1129	1113	1086	1058	1028	997	914	808	-	-	-
	<b>Low</b>	<b>1</b>	G			1007	989	971	958	945	925	904	889	873	862	850	818	778	-	-	-
048	<b>High</b>	<b>5</b>	W	11 x 10	1	1890	1874	1857	1845	1833	1809	1784	1769	1754	1736	1718	1672	1629	1601	1562	1522
	<b>Med High</b>	<b>4</b>	Y2			1769	1754	1739	1721	1703	1685	1666	1645	1623	1604	1585	1539	1499	1463	1432	1376
	Med	3				1671	1652	1632	1614	1595	1576	1557	1536	1514	1494	1474	1430	1387	1351	1313	1173
	<b>Med Low</b>	<b>2</b>	Y1			1574	1555	1535	1514	1492	1472	1452	1431	1410	1387	1363	1330	1284	1236	1108	1014
	<b>Low</b>	<b>1</b>	G			1388	1370	1352	1322	1292	1264	1236	1216	1195	1178	1161	1095	984	916	842	787
060	<b>High</b>	<b>5</b>	W	11 x 10	1	2077	2066	2055	2044	2033	2017	2000	1966	1931	1904	1877	1841	1810	1791	1740	1653
	<b>Med High</b>	<b>4</b>	Y2			1948	1937	1925	1910	1895	1880	1865	1831	1797	1778	1759	1720	1707	1680	1660	1612
	Med	3				1810	1794	1778	1739	1700	1684	1667	1657	1646	1629	1612	1576	1583	1547	1510	1480
	<b>Med Low</b>	<b>2</b>	Y1			1680	1667	1653	1618	1583	1562	1540	1522	1503	1488	1473	1465	1449	1410	1369	1319
	<b>Low</b>	<b>1</b>	G			1594	1572	1550	1512	1474	1450	1426	1410	1393	1385	1376	1351	1325	1290	1168	1085
072	<b>High</b>	<b>5</b>	W	11 x 10	1	2402	2388	2373	2358	2343	2334	2325	2307	2289	2274	2258	2215	2177	2125	2052	1933
	<b>Med High</b>	<b>4</b>	Y2			2209	2193	2177	2164	2151	2135	2118	2105	2092	2072	2052	2017	1982	1954	1925	1844
	Med	3				2085	2072	2058	2045	2031	2010	1989	1972	1954	1936	1918	1881	1852	1821	1790	1751
	<b>Med Low</b>	<b>2</b>	Y1			1961	1951	1940	1926	1911	1885	1859	1844	1829	1814	1798	1759	1727	1703	1670	1636
	<b>Low</b>	<b>1</b>	G			1767	1751	1735	1715	1694	1678	1661	1640	1619	1602	1584	1548	1512	1475	1426	1397

Factory speed settings are in Bold

Air flow values are with dry coil and standard filter

For wet coil performance first calculate the face velocity of the air coil (Face Velocity [fpm] = Airflow [cfm] / Face Area [sq ft]).

Then for velocities of 200 fpm reduce the static capability by 0.03 in. wg, 300 fpm by 0.08 in. wg, 400 fpm by 0.12 in. wg., and 500 fpm by 0.16 in. wg.

Highest setting is for auxiliary heat (W) and lowest setting is for constant blower (G). The "Y1" and "Y2" settings must be between the "G" and "W" settings.

7/30/14

## Setting Blower Speed - 5-Speed ECM

5-Speed ECM blower motors have five (5) speeds of which four (4) are selectable on dual capacity.



**CAUTION: Disconnect all power before performing this operation.**

## 5-Speed ECM Motor Connections - Dual Capacity

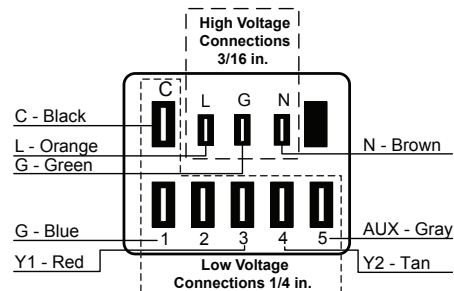

# Antifreeze Corrections

Catalog performance can be corrected for antifreeze use. Please use the following table and note the example given.

Antifreeze Type EWT - °F [°C]	Antifreeze % by wt	Heating 30 [-1.1]	Cooling 90 [32.2]	Pressure Drop 30 [-1.1]
Water	0	1.000	1.000	1.000
	10	0.973	0.991	1.075
Ethylene Glycol	20	0.943	0.979	1.163
	30	0.917	0.965	1.225
	40	0.890	0.955	1.324
	50	0.865	0.943	1.419
	10	0.958	0.981	1.130
Propylene Glycol	20	0.913	0.969	1.270
	30	0.854	0.950	1.433
	40	0.813	0.937	1.614
	50	0.770	0.922	1.816
	10	0.927	0.991	1.242
Ethanol	20	0.887	0.972	1.343
	30	0.856	0.947	1.383
	40	0.815	0.930	1.523
	50	0.779	0.911	1.639
	10	0.957	0.986	1.127
Methanol	20	0.924	0.970	1.197
	30	0.895	0.951	1.235
	40	0.863	0.936	1.323
	50	0.833	0.920	1.399

 **WARNING: Gray area represents antifreeze concentrations greater than 35% by weight and should be avoided due to the extreme performance penalty they represent.**

## Antifreeze Correction Example

Antifreeze solution is Propylene Glycol 20% by weight. Determine the corrected heating and cooling performance at 30°F and 90°F respectively as well as pressure drop at 30°F for a 036.

The corrected cooling capacity at 90°F would be: 34,800 Btu/h x 0.969 = 33,721 Btu/h

The corrected heating capacity at 30°F would be: 29,300 Btu/h x 0.913 = 26,750 Btu/h

The corrected pressure drop at 30°F and 9 gpm would be: 13.4 feet of head x 1.270 = 17.02 feet of head

# Correction Factor Tables

## Air Flow Corrections (Dual Capacity Part Load)

Airflow		Cooling				Heating		
cfm Per Ton of Clg	% of Nominal	Total Cap	Sens Cap	Power	Heat of Rej	Htg Cap	Power	Heat of Ext
240	60	0.922	0.778	0.956	0.924	0.943	1.239	0.879
275	69	0.944	0.830	0.962	0.944	0.958	1.161	0.914
300	75	0.957	0.866	0.968	0.958	0.968	1.115	0.937
325	81	0.970	0.900	0.974	0.970	0.977	1.075	0.956
350	88	0.982	0.933	0.981	0.980	0.985	1.042	0.972
375	94	0.991	0.968	0.991	0.991	0.993	1.018	0.988
<b>400</b>	<b>100</b>	<b>1.000</b>	<b>1.000</b>	<b>1.000</b>	<b>1.000</b>	<b>1.000</b>	<b>1.000</b>	<b>1.000</b>
425	106	1.007	1.033	1.011	1.008	1.007	0.990	1.010
450	113	1.013	1.065	1.023	1.015	1.012	0.987	1.018
475	119	1.017	1.099	1.037	1.022	1.018	0.984	1.025
500	125	1.020	1.132	1.052	1.027	1.022	0.982	1.031
520	130	1.022	1.159	1.064	1.030	1.025	0.979	1.034

5/30/06

## Air Flow Corrections (Dual Capacity Full Load)

Airflow		Cooling				Heating		
cfm Per Ton of Clg	% of Nominal	Total Cap	Sens Cap	Power	Heat of Rej	Htg Cap	Power	Heat of Ext
240	60	0.922	0.786	0.910	0.920	0.943	1.150	0.893
275	69	0.944	0.827	0.924	0.940	0.958	1.105	0.922
300	75	0.959	0.860	0.937	0.955	0.968	1.078	0.942
325	81	0.971	0.894	0.950	0.967	0.977	1.053	0.959
350	88	0.982	0.929	0.964	0.978	0.985	1.031	0.973
375	94	0.992	0.965	0.982	0.990	0.993	1.014	0.988
<b>400</b>	<b>100</b>	<b>1.000</b>	<b>1.000</b>	<b>1.000</b>	<b>1.000</b>	<b>1.000</b>	<b>1.000</b>	<b>1.000</b>
425	106	1.007	1.034	1.020	1.010	1.007	0.990	1.011
450	113	1.012	1.065	1.042	1.018	1.013	0.983	1.020
475	119	1.017	1.093	1.066	1.026	1.018	0.980	1.028
500	125	1.019	1.117	1.092	1.033	1.023	0.978	1.034
520	130	1.020	1.132	1.113	1.038	1.026	0.975	1.038

5/30/06

## Cooling Capacity Corrections

Entering Air WB °F	Total Clg Cap	Sensible Cooling Capacity Multipliers - Entering DB °F										Power Input	Heat of Rejection
		60	65	70	75	80	80.6	85	90	95	100		
55	0.898	0.723	0.866	1.048	1.185	*	*	*	*	*	*	0.985	0.913
60	0.912		0.632	0.880	1.078	1.244	1.260	*	*	*	*	0.994	0.927
63	0.945			0.768	0.960	1.150	1.175	*	*	*	*	0.996	0.954
65	0.976			0.694	0.881	1.079	1.085	1.270	*	*	*	0.997	0.972
66.2	0.983			0.655	0.842	1.040	1.060	1.232	*	*	*	0.999	0.986
<b>67</b>	<b>1.000</b>			0.616	0.806	<b>1.000</b>	1.023	1.193	1.330	1.480	*	<b>1.000</b>	<b>1.000</b>
70	1.053				0.693	0.879	0.900	1.075	1.205	1.404	*	1.003	1.044
75	1.168					0.687	0.715	0.875	1.040	1.261	1.476	1.007	1.141

NOTE: \* Sensible capacity equals total capacity at conditions shown.

3/28/12

## Heating Capacity Corrections

Ent Air DB °F	Heating Corrections		
	Htg Cap	Power	Heat of Ext
45	1.062	0.739	1.158
50	1.050	0.790	1.130
55	1.037	0.842	1.096
60	1.025	0.893	1.064
65	1.012	0.945	1.030
68	1.005	0.976	1.012
<b>70</b>	<b>1.000</b>	<b>1.000</b>	<b>1.000</b>
75	0.987	1.048	0.970
80	0.975	1.099	0.930

11/10/09

## Heat of Extraction/Heat of Rejection

Model	GPM	Heat of Extraction (kBtuh)				Heat of Rejection (kBtuh)					
		30°F	50°F	70°F	90°F	30°F	50°F	70°F	90°F	110°F	
024	Part Load	3.0		12.4	16.8	18.8		20.8	20.1	19.1	
		5.0	9.3	12.9	17.3	20.1	19.5	21.0	20.1	19.4	19.5
		7.0	9.5	13.2	17.8	20.8	19.7	21.2	20.2	19.5	19.5
	Full Load	4.0		16.5	23.7	25.9		29.5	30.4	28.8	
		6.0	13.5	17.2	23.1	27.6	28.4	29.7	30.4	29.3	27.4
		8.0	13.9	17.6	23.9	28.6	28.6	29.9	30.6	29.5	27.5
036	Part Load	4.0		19.3	24.4	28.9		31.8	32.3	30.8	
		6.0	14.1	20.1	25.5	30.9	29.2	32.2	32.5	31.4	30.9
		8.0	14.4	20.6	26.3	32.0	29.4	32.4	32.7	31.5	31.0
	Full Load	5.0		26.6	33.2	38.3		43.5	44.2	42.8	
		7.0	20.1	27.7	34.4	40.9	38.0	43.8	45.0	43.6	42.9
		9.0	20.6	28.4	35.5	42.3	38.3	44.1	45.3	43.8	43.1
048	Part Load	5.0		24.5	29.2	34.4		42.6	41.6	40.6	
		8.0	16.4	25.6	30.5	36.5	37.3	42.9	41.9	40.7	40.3
		11.0	17.8	26.9	31.3	36.5	37.6	43.5	42.1	41.2	40.7
	Full Load	6.0		34.8	40.4	44.2		62.7	61.5	57.1	
		9.0	25.1	36.4	42.0	47.2	52.9	63.2	61.8	58.2	53.1
		12.0	25.7	37.3	43.4	49.0	53.2	63.6	62.0	58.4	53.5
060	Part Load	6.0		31.2	37.8	48.5		52.8	52.7	51.1	
		10.0	22.0	32.7	40.3	51.6	46.2	54.0	53.4	51.2	48.1
		14.0	23.9	34.4	41.3	51.6	46.5	54.8	53.6	51.8	48.5
	Full Load	8.0		42.4	54.6	66.2		71.0	71.3	70.9	
		12.0	33.1	44.3	57.3	70.5	61.7	71.9	71.5	70.0	70.0
		16.0	35.8	46.7	58.8	70.6	62.1	72.8	72.2	71.7	70.7
072	Part Load	10.0		37.9	50.1	59.5		57.6	61.8	59.5	
		13.0	26.8	39.6	51.3	63.3	56.6	62.5	62.6	59.6	61.0
		16.0	29.0	41.7	52.6	63.3	57.0	63.3	62.8	60.3	61.6
	Full Load	12.0		52.6	67.4	76.9		80.8	80.8	77.9	
		15.0	40.0	54.9	68.3	82.2	69.6	81.3	81.2	79.3	81.4
		18.0	40.9	56.3	70.5	85.2	70.0	81.8	81.6	79.6	81.7

Note: operation not recommended in shaded areas.

6/10/24

## Water Quality

Material		Copper	90/10 Cupronickel	316 Stainless Steel
pH	Acidity/Alkalinity	7 - 9	7 - 9	7 - 9
Scaling	Calcium and Magnesium Carbonate	(Total Hardness) less than 350 ppm	(Total Hardness) less than 350 ppm	(Total Hardness) less than 350 ppm
Corrosion	Hydrogen Sulfide	Less than 0.5 ppm (rotten egg smell appears at 0.5 ppm)	10 - 50 ppm	Less than 1 ppm
	Sulfates	Less than 125 ppm	Less than 125 ppm	Less than 200 ppm
	Chlorine	Less than 0.5 ppm	Less than 0.5 ppm	Less than 0.5 ppm
	Chlorides	Less than 20 ppm	Less than 125 ppm	Less than 300 ppm
	Carbon Dioxide	Less than 50 ppm	10 - 50 ppm	10 - 50 ppm
	Ammonia	Less than 2 ppm	Less than 2 ppm	Less than 20 ppm
	Ammonia Chloride	Less than 0.5 ppm	Less than 0.5 ppm	Less than 0.5 ppm
	Ammonia Nitrate	Less than 0.5 ppm	Less than 0.5 ppm	Less than 0.5 ppm
	Ammonia Hydroxide	Less than 0.5 ppm	Less than 0.5 ppm	Less than 0.5 ppm
	Ammonia Sulfate	Less than 0.5 ppm	Less than 0.5 ppm	Less than 0.5 ppm
	Total Dissolved Solids (TDS)	Less than 1000 ppm	1000 - 1500 ppm	1000 - 1500 ppm
	LSI Index	+0.5 to -0.5	+0.5 to -0.5	+0.5 to -0.5
Iron Fouling (Biological Growth)	Iron, FE <sup>2+</sup> (Ferrous) Bacterial Iron Potential	< 0.2 ppm	< 0.2 ppm	< 0.2 ppm
	Iron Oxide	Less than 1 ppm, above this level deposition will occur	Less than 1 ppm, above this level deposition will occur	Less than 1 ppm, above this level deposition will occur
Erosion	Suspended Solids	Less than 10 ppm and filtered for max. of 600 micron size	Less than 10 ppm and filtered for max. of 600 micron size	Less than 10 ppm and filtered for max. of 600 micron size
	Threshold Velocity (Fresh Water)	< 6 ft/sec	< 6 ft/sec	< 6 ft/sec

NOTES: Grains = ppm divided by 17  
mg/L is equivalent to ppm

2/22/12

## Water Quality

It is the responsibility of the system designer and installing contractor to ensure that acceptable water quality is present and that all applicable codes have been met in these installations. Failure to adhere to the guidelines in the water quality table could result in loss of warranty. In ground water situations where scaling could be heavy or where biological growth such as iron bacteria will be present, a closed loop system is recommended. The heat exchanger coils in ground water systems may, over a period of time, lose heat exchange capabilities due to a buildup of mineral deposits inside. These can be cleaned, but only by a qualified service mechanic, as special solutions and pumping equipment are required. Hot water generator coils can likewise become scaled and possibly plugged. In areas with extremely hard water, the owner should be informed that the heat exchanger may require occasional flushing.

Heat pumps with cupronickel heat exchangers are recommended for open loop applications due to the increased resistance to build-up and corrosion, along with reduced wear caused by acid cleaning.

## Water Treatment

Do not use untreated or improperly treated water. Equipment damage may occur. The use of improperly treated or untreated water in this equipment may result in scaling, erosion, corrosion, algae or slime. Purchase of a pre-mix antifreeze could significantly improve system reliability if the water quality is

controlled and there are additives in the mixture to inhibit corrosion. There are many examples of such fluids on the market today such as Environol™ 1000 (pre-mix ethanol), and others. The services of a qualified water treatment specialist should be engaged to determine what treatment, if any, is required. The product warranty specifically excludes liability for corrosion, erosion or deterioration of equipment.

The heat exchangers and water lines in the units are copper or cupronickel tube. There may be other materials in the buildings piping system that the designer may need to take into consideration when deciding the parameters of the water quality. If antifreeze or water treatment solution is to be used, the designer should confirm it does not have a detrimental effect on the materials in the system.

## Contaminated Water

In applications where the water quality cannot be held to prescribed limits, the use of a secondary or intermediate heat exchanger is recommended to separate the unit from the contaminated water. The table above outlines the water quality guidelines for unit heat exchangers. If these conditions are exceeded, a secondary heat exchanger is required. Failure to supply a secondary heat exchanger where needed will result in a warranty exclusion for primary heat exchanger corrosion or failure.

# Operating Parameters

## Dual Capacity Models First Stage Operation

Entering Water Temp °F	Water Flow gpm/ton	Cooling -- No Hot Water Generation					
		Suction Pressure psig	Discharge Pressure psig	Superheat	Subcooling	Water Temp Rise °F	Air Temp Drop °F DB
30	1.5	105 - 125	140 - 155	20 - 35	7 - 17	17 - 21	17 - 25
	3.0	90 - 120	115 - 130	20 - 35	7 - 17	5 - 12	17 - 25
50	1.5	125 - 140	205 - 225	12 - 20	5 - 14	17 - 21	17 - 25
	3.0	115 - 135	170 - 195	12 - 20	5 - 14	5 - 12	17 - 25
70	1.5	130 - 145	280 - 290	10 - 16	5 - 14	16 - 20	17 - 25
	3.0	120 - 143	230 - 260	10 - 16	5 - 14	5 - 13	17 - 25
90	1.5	138 - 152	345 - 355	6 - 12	5 - 14	14 - 20	17 - 25
	3.0	130 - 150	300 - 340	6 - 12	5 - 14	5 - 12	17 - 25
110	1.5	152 - 158	405 - 435	6 - 12	5 - 14	14 - 20	17 - 25
	3.0	135 - 153	390 - 420	6 - 12	5 - 14	5 - 12	17 - 25

Entering Water Temp °F	Water Flow gpm/ton	Heating -- No Hot Water Generation					
		Suction Pressure psig	Discharge Pressure psig	Superheat	Subcooling	Water Temp Drop °F	Air Temp Rise °F DB
30	1.5	75 - 90	265 - 280	8 - 12	3 - 10	5 - 9	12 - 25
	3.0	75 - 88	270 - 290	8 - 12	3 - 10	3 - 7	14 - 26
50	1.5	100 - 115	280 - 310	10 - 14	3 - 10	7 - 11	18 - 28
	3.0	105 - 120	295 - 325	10 - 14	3 - 10	5 - 9	20 - 33
70	1.5	135 - 150	310 - 325	12 - 16	3 - 10	8 - 12	24 - 39
	3.0	140 - 155	330 - 370	12 - 16	3 - 10	4 - 10	22 - 41
90	1.5	160 - 170	330 - 390	12 - 16	3 - 10	8 - 12	24 - 45
	3.0	170 - 185	370 - 430	12 - 16	3 - 10	5 - 10	22 - 47
110	1.5						
	3.0						

Note: Cooling performance based on entering air temperatures of 80° F DB, 67° F WB.  
Heating performance based on entering air temperature of 70° F DB.

## Second Stage Operation

Entering Water Temp °F	Water Flow gpm/ton	Cooling -- No Hot Water Generation					
		Suction Pressure psig	Discharge Pressure psig	Superheat	Subcooling	Water Temp Rise °F	Air Temp Drop °F DB
30	1.5	115 - 125	150 - 170	20 - 35	10 - 17	17 - 22	17 - 25
	3.0	95 - 120	125 - 145	20 - 35	10 - 17	8 - 10	17 - 25
50	1.5	125 - 138	210 - 230	12 - 20	8 - 14	16 - 22	17 - 25
	3.0	115 - 125	175 - 200	12 - 20	8 - 14	8 - 12	17 - 25
70	1.5	128 - 138	270 - 300	10 - 16	10 - 16	15 - 21	17 - 25
	3.0	115 - 128	240 - 270	10 - 16	8 - 14	7 - 13	17 - 25
90	1.5	135 - 145	360 - 390	9 - 14	10 - 16	14 - 20	17 - 25
	3.0	120 - 130	320 - 350	9 - 14	8 - 14	6 - 10	17 - 25
110	1.5	145 - 155	420 - 450	9 - 14	10 - 16	14 - 20	17 - 25
	3.0	135 - 153	400 - 435	9 - 14	8 - 14	6 - 10	17 - 25

Entering Water Temp °F	Water Flow gpm/ton	Heating -- No Hot Water Generation					
		Suction Pressure psig	Discharge Pressure psig	Superheat	Subcooling	Water Temp Drop °F	Air Temp Rise °F DB
30	1.5	60 - 75	270 - 305	8 - 14	5 - 15	5 - 10	15 - 26
	3.0	65 - 78	280 - 315	8 - 14	5 - 15	3 - 8	17 - 28
50	1.5	87 - 100	290 - 325	10 - 16	5 - 15	7 - 13	22 - 33
	3.0	95 - 115	310 - 335	10 - 16	5 - 15	4 - 11	24 - 35
70	1.5	130 - 145	340 - 360	10 - 19	5 - 15	10 - 14	30 - 41
	3.0	130 - 150	345 - 375	10 - 19	5 - 15	6 - 12	32 - 43
90	1.5	160 - 175	360 - 400	10 - 19	5 - 20	10 - 18	30 - 40
	3.0	165 - 180	375 - 410	13 - 22	5 - 20	8 - 12	32 - 50
110	1.5						
	3.0						

Note: Cooling performance based on entering air temperatures of 80° F DB, 67° F WB.  
Heating performance based on entering air temperature of 70° F DB.

6/21/24

## Pressure Drop

Model	GPM	Pressure Drop (psi)				
		30°F	50°F	70°F	90°F	110°F
<b>024 full load</b>	4	1.9	1.8	1.7	1.6	1.5
	6	5.3	5.0	4.7	4.4	4.1
	8	8.7	8.2	7.7	7.2	6.7
	10	12.1	11.4	10.5	10	9.3
<b>024 part load</b>	3	1.0	1.0	0.9	0.8	0.8
	5	3.9	3.6	3.4	3.2	2.9
	7	6.5	6.1	5.7	5.3	4.9
	9	9.1	8.6	7.9	7.4	6.9
<b>036 full load</b>	5	2.3	2.1	2.0	1.9	1.7
	7	4.4	4.2	3.9	3.6	3.4
	9	6.6	6.2	5.8	5.4	5.0
	11	8.8	8.2	7.4	7.2	6.6
<b>036 part load</b>	4	1.5	1.4	1.3	1.2	1.1
	6	3.3	3.1	2.9	2.7	2.5
	8	5.2	4.9	4.6	4.3	4.0
	10	7.1	6.7	6.2	5.9	5.5
<b>048 full load</b>	6	6.8	6.4	6.0	5.6	5.2
	9	9.4	8.9	8.3	7.7	7.2
	12	12.0	11.3	10.6	9.9	9.2
	15	14.6	13.7	12.8	12.1	11.2
<b>048 part load</b>	5	5.6	5.2	4.9	4.6	4.2
	8	8.0	7.5	7.0	6.5	6.0
	11	10.1	9.5	8.9	8.3	7.7
	14	14.0	13.1	12.2	11.5	10.6
<b>060 full load</b>	8	7.3	6.8	6.4	6.0	5.5
	12	11.6	10.9	10.2	9.5	8.8
	16	15.9	15.0	14.0	13.0	12.1
	20	20.2	19.1	17.8	16.5	15.4
<b>060 part load</b>	6	4.3	4.1	3.8	3.5	3.3
	10	8.4	7.9	7.4	6.9	6.4
	14	12.7	12.0	11.2	10.4	9.7
	18	17.0	16.1	15.1	13.9	13.0
<b>072 full load</b>	12	3.8	3.6	3.4	3.1	2.9
	15	5.7	5.3	5.0	4.7	4.3
	18	7.8	7.4	6.9	6.4	6.0
	21	9.9	9.5	9.1	8.1	7.7
<b>072 part load</b>	10	2.8	2.7	2.5	2.3	2.2
	13	4.8	4.5	4.2	3.9	3.8
	16	6.8	6.4	6.0	5.6	5.4
	19	8.8	8.3	7.6	7.3	7.0

6/10/24

## Operation Logic Data Table

Operation Logic Table	Heating					Cooling		
	STG1	STG2	STG3	EMERG	Fan Only	STG1	STG2	Fan Only
Compressor	On	On	On	Off	Off	On	On	Off
Reversing Valve	Off	Off	Off	Off	Off	On	On	On
Aux Heat	Off	Off	Staged	Staged	Off	Off	Off	Off
Acc Relay	On	On	On	Off	Off	On	On	Off
5 Speed ECM	Med Low	Med High	High	High	Low	Med Low	Med High	Low
T-Stat Signal	Y1	Y1,Y2	Y1,Y2,W	W	G	Y1,O	Y1,Y2,O	G

2/13/2012

# Aurora Control System

## Aurora 'Base' Control









The Aurora 'Base' Control (ABC) System is a complete residential and commercial comfort system that brings all aspects of the HVAC system into one cohesive module network. The ABC features microprocessor control and HP, LP, condensate and freeze detection,

over/under voltage faults, along with communicating thermostat capability for complete fault detection text

at the thermostat. Aurora uses the Modbus communication protocol to communicate between modules. Each module contains the logic to control all features that are connected to the module. The Aurora 'Base' Control (ABC) has two Modbus channels. The first channel is configured as a master for connecting to devices such as a communicating thermostat or other slave devices. The second channel is configured as a slave for connecting the Aurora Interface Diagnostics Tool (AID Tool).

Aurora Control Features	Description	Aurora 'Base'
<b>Microprocessor Compressor Control</b>	Microprocessor control of compressor for timings with FP1, HP, LP, Condensate, assignable Acc relay	•
<b>Base Hot Water Generator Operation</b>	Compressor Contactor powers Hot Water Generator Pump with inline circuit breaker and thermostat limit.	•
<b>Base Loop Pump Control</b>	Compressor Contactor powers Loop Pump with inline circuit breaker and no loop pump slaving capability.	•
<b>Load Shed/Utility Input</b>	Allows simple input to externally enable of occupied/unoccupied mode for basic utility time of use programs.	•
<b>AWL/Symphony</b>	Allows direct communication of the Aurora to AWL and the Internet.	Optional

Service Device	Description	Aurora 'Base'
 <b>Aurora Interface and Diagnostics (AID) Tool</b>	Allows setup, monitoring and troubleshooting of any Aurora Control.  <b>NOTE:</b> Although the ABC has basic compatibility with all Aurora, new product features may not be available on older AID Tools.	For Service (Ver. 2.xx or greater)

Add On Thermostats and Zoning	Description	Aurora 'Base'
 <b>TP32U03/04 - MonoChrome Traditional Y1, Y2 Thermostat</b>	Elite Stat with full English fault codes and alerts, traditional Y1, Y2 thermostat, 8 wire installation	Optional
 <b>TP32S01/02 - Traditional Y1, Y2 Thermostat</b>	Traditional Y1, Y2 thermostat, 8 wire installation	Optional
 <b>TPCM32U03A/04A - MonoChrome Communicating Thermostat</b>	Elite Stat with full English fault codes and alerts, communicating thermostat, 4 wire installation	Optional
 <b>TPCC Series Touchscreen Communicating Thermostat</b>	4.3 in. color touchscreen communicating thermostat with full English fault codes and alerts, 4 wire installation	Optional
 <b>IntelliZone2 • 24V Zoning</b>	IntelliZone2 • 24V is a communicating zoning system that includes color main thermostat and up to 4 zones (with dual capacity). There are 3 thermostat options (MasterStat, SensorStat, ZoneStat). Includes daughter board to translate communication to 24VAC for heat pump	Optional

# Aurora Control System

## Aurora 'Base' Control

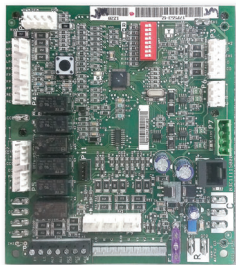

**NOTE:** Refer to the Aurora Base Control Application and Troubleshooting Guide and the Instruction Guide: Aurora Interface and Diagnostics (AID) Tool for additional information.

## Control Features

### Software ABC Standard Version 4.0

### 5-Speed ECM Blower Motor

A 5-Speed ECM blower motor will be driven directly using the thermostat connections. Any of the G, Y1, or Y2/W signals can drive any of the 5 available pre-programmed blower speeds on the motor.

## Other Control Features

- Random start at power up
- Anti-short cycle protection
- High and low pressure cutouts
- Loss of charge
- Water coil freeze detection
- Over/under voltage protection
- Condensate overflow sensor
- Load shed
- Emergency shutdown
- Diagnostic LED
- Test mode push button switch
- Two auxiliary electric heat outputs
- Alarm output
- Accessory output with N.O. and N.C.
- Modbus communication (master)
- Modbus communication (slave)

## Field Selectable Options via Hardware

**DIP Switch (SW1)** - Test/Configuration Button (See SW1 Operation Table)

### Test Mode

The control is placed in the test mode by holding the push button switch SW1 for 2 - 5 seconds. In test mode most of the control timings will be shortened by a factor of sixteen (16). LED3 (green) will flash at 1 second on and 1 second off. Additionally, when entering test mode LED1 (red) will flash the last lockout one time. Test mode will automatically time out after 30 minutes. Test mode can be exited by pressing and holding the SW1 button for 2 to 5 seconds or

by cycling the power. **NOTE:** Test mode will automatically be exited after 30 minutes.

### Reset Configuration Mode

The control is placed in reset configuration mode by holding the push button switch SW1 for 50 to 60 seconds. This will reset all configuration settings and the EEPROM back to the factory default settings. LED3 (green) will turn off when entering reset configuration mode. Once LED3 (green) turns off, release SW1 and the control will reset.

### DIP Switch (SW2)

- SW2-1** FP1 Selection - Low water coil temperature limit setting for freeze detection. On = 30°F; Off = 15°F.
- SW2-2** Not Used
- SW2-3** RV - O/B - thermostat type. Heat pump thermostats with "O" output in cooling or "B" output in Heating can be selected. On = O; Off = B.
- SW2-4** Access Relay Operation (P2)

and 2-5

Access Relay Operation	SW2-4	SW2-5
Cycle with Blower	ON	ON
Cycle with Compressor	OFF	OFF
Water Valve Slow Opening	ON	OFF
Cycle with Comm. T-stat Hum Cmd	OFF	ON

**Cycle with Blower** - The accessory relay will cycle with the blower output.

**Cycle with Compressor** - The accessory relay will cycle with the compressor output.

**Water Valve Slow Opening** - The accessory relay will cycle and delay both the blower and compressor output for 90 seconds.

**SW2-6** CC Operation - selection of single or dual capacity compressor. On = Single Stage; Off = Dual Capacity

**SW2-7** Lockout and Alarm Outputs (P2) - selection of a continuous or pulsed output for both the LO and ALM Outputs. On = Continuous; Off = Pulsed

**SW2-8** Future Use

### Alarm Jumper Clip Selection

From the factory, ALM is connected to 24 VAC via JW2. By cutting JW2, ALM becomes a dry contact connected to ALG.

## Aurora Control System

### Field Selectable Options via Software

*(Selectable via the Aurora AID Tool)*

#### Safety Features

The following safety features are provided to protect the compressor, heat exchangers, wiring and other components from damage caused by operation outside of design conditions.

**Fuse** - a 3 amp automotive type plug-in fuse provides protection against short circuit or overload conditions.

**Anti-Short Cycle Protection** - 4 minute anti-short cycle protection for the compressor.

**Random Start** - 5 to 80 second random start upon power up.

**Fault Retry** - in the fault condition, the control will stage off the outputs and then "try again" to satisfy the thermostat Y input call. Once the thermostat input calls are satisfied, the control will continue on as if no fault occurred. If 3 consecutive faults occur without satisfying the thermostat Y input call, then the control will go to Lockout mode.

**Lockout** - when locked out, the blower will operate continuously. The Alarm output (ALM) and Lockout output (L) will be turned on. The fault type identification display LED1 (Red) shall flash the fault code. To reset lockout conditions with SW2-8 On, thermostat inputs "Y1", "Y2", and "W" must be removed for at least 3 seconds. To reset lockout conditions with SW2-8 Off, thermostat inputs "Y1", "Y2", "W", and "DH" must be removed for at least 3 seconds. Lockout may also be reset by turning power off for at least 30 seconds or by enabling the emergency shutdown input for at least 3 seconds.

**Lockout With Emergency Heat** - if the control is locked out in the heating mode and W input is received, the control will operate in the emergency heat mode while the compressor is locked out. The first emergency heat output will be energized 10 seconds after the W input is received, and the blower will shift to high speed. If the control remains locked out, and the W input is present, additional stage of emergency heat will stage on after 2 minutes. When the W input is removed, all of the emergency heat outputs and blower will turn off.

**High Pressure** - fault is recognized when the Normally Closed High Pressure Switch, P4-9/10 opens, no matter how momentarily. The High Pressure Switch is electrically in series with the Compressor Contactor and serves as a hard-wired limit switch if an overpressure condition should occur.

**Low Pressure** - fault is recognized when the Normally Closed Low Pressure Switch, P4-7/8 is continuously open for 30 seconds. Closure of the LPS any time during the 30 second recognition time restarts the 30 second continuous

open requirement. A continuously open LPS shall not be recognized during the 2 minute startup bypass time.

**Loss of Charge** - fault is recognized when the Normally Closed Low Pressure Switch, P4-7/8 is open prior to the compressor starting.

**Condensate Overflow** - fault is recognized when the impedance between this line and 24 VAC common or chassis ground drops below 100K ohms for 30 seconds continuously.

**Freeze Detection (Coax)** - set points shall be either 30°F or 15°F. When the thermistor temperature drops below the selected set point, the control shall begin counting down the 30 seconds delay. If the thermistor value rises above the selected set point, then the count should reset. The resistance value must remain below the selected set point for the entire length of the appropriate delay to be recognized as a fault. This fault will be ignored for the initial 2 minutes of the compressor run time.

**Over/Under Voltage Shutdown** - An over/under voltage condition exists when the control voltage is outside the range of 18 VAC to 30 VAC. If the over/under voltage shutdown lasts for 15 minutes, the lockout and alarm relay will be energized. Over/under voltage shutdown is self-resetting in that if the voltage comes back within range of 18 VAC to 30 VAC for at least 0.5 seconds, then normal operation is restored.

### Operation Description

**Power Up** - The unit will not operate until all the inputs and safety controls are checked for normal conditions. The unit has a 5 to 80 second random start delay at power up. Then the compressor has a 4 minute anti-short cycle delay after the random start delay.

**Standby** In standby mode, Y1, Y2, W, DH, and G are not active. Input O may be active. The blower and compressor will be off.

#### Heating Operation

**Heating, 1st Stage (Y1)** - The blower is started on "Y1" speed immediately and the compressor is energized 10 seconds after the Y1 input is received.

**Heating, 2nd Stage (Y1, Y2)** - The compressor will be staged to full capacity 20 seconds after Y2 input is received. The 5 speed ECM blower will shift to Y2 speed immediately.

**Heating, 3rd Stage (Y1, Y2, W)** - The first stage of electric heat is energized 10 seconds after the W command is received. Blower will increase to "W" speed immediately. If the demand continues the second stage of electric heat will be energized after 5 minutes.

# Aurora Control System

**Emergency Heat (W)** - The blower will be started on “W” speed, 10 seconds later the first stage of electric heat will be turned on. If the emergency heat demand is not satisfied after 2 minutes the second electric heat stage will be energized.

**Blower (G)** - The blower will start immediately upon receiving a thermostat G command. If there are no other commands from the thermostat the ECM will run on “G” speed until the G command is removed. Regardless of blower input (G) from the thermostat, the blower will remain on for 30 seconds at the end of each heating cycle.

### Cooling Operation

In all cooling operations, the reversing valve directly tracks the O input. Thus, anytime the O input is present, the reversing valve will be energized.

**Cooling, 1st Stage (Y1, O)** - The blower is started on “Y1” speed immediately and the compressor is energized 10 seconds after the Y1 input is received.

**Cooling, 2nd Stage (Y1, Y2, O)** - The compressor will be staged to full capacity 20 seconds after Y2 input is received. The 5 speed ECM blower will shift to Y2 speed immediately.

**Emergency Shutdown** - Four (4) seconds after a valid ES input, P2-7 is present, all control outputs will be turned off and remain off until the emergency shutdown input is no longer present. The first time that the compressor is started after the control exits the emergency shutdown mode, there will be an anti-short cycle delay followed by a random start delay. Input must be tied to common to activate.

**Continuous Blower Operation** - The blower output will be energized any time the control has a G input present, unless the control has an emergency shutdown input present. The blower output will be turned off when G input is removed.

**Load Shed** - The LS input disables all outputs with the exception of the blower output. When the LS input has been cleared, the anti-short cycle timer and random start timer will be initiated. Input must be tied to common to activate.

## Aurora ‘Base’ Control LED Displays

These three LEDs display the status, configuration, and fault codes for the control. These can also be read in plain English via the Aurora AID Tool.

### Status LED (LED3, Green)

Description of Operation	Fault LED, Green
Normal Mode	ON
Control is Non-functional	OFF
Test Mode	Slow Flash
Lockout Active	Fast Flash
Dehumidification Mode	Flash Code 2
(Future Use)	Flash Code 3
(Future Use)	Flash Code 4
Load Shed	Flash Code 5
Emergency Shutdown	Flash Code 6
Smart Grid	Flash Code 7

### Configuration LED (LED2, Yellow)

Description of Operation	Configuration LED, Yellow
No Software Overwritten	Flashing ECM Setting
DIP Switch was Overwritten	Slow Flash
ECM Configuration Mode	Fast Flash

### Fault LED (LED1, Red)

Red Fault LED	LED Flash Code*	Lockout	Reset/ Remove	Fault Condition Summary	
Normal - No Faults	Off				
ABC Basic Faults	Fault-Input	1	No	Auto	Tstat input error. Autoreset upon condition removal.
	Fault-High Pressure	2	Yes	Hard or Soft	HP switch has tripped (>600 psi)
	Fault-Low Pressure	3	Yes	Hard or Soft	Low Pressure Switch has tripped (<40 psi for 30 continuous sec.)
	Fault-Freeze Detection FP2	4	Yes	Hard or Soft	Freeze protection sensor has tripped (<15 or 30 degF for 30 continuous sec.)
	Fault-Freeze Detection FP1	5	Yes	Hard or Soft	Freeze protection sensor has tripped (<15 or 30 degF for 30 continuous sec.)
	Fault-Loss of Charge	6	Yes	Hard or Soft	Low Pressure Switch open prior to compressor start (UPC Only)
	Fault-Condensate Overflow	7	Yes	Hard or Soft	Condensate switch has shown continuity for 30 continuous sec.
	Fault-Over/Under Voltage	8	No**	Auto	Instantaneous Voltage is out of range. **Controls shut down until resolved.
	Fault-Compressor Monitor	10	Yes	Hard or Soft	Open Crkt, Run, Start or welded cont
	Fault-FP1 & 2 Snsr Error	11	Yes	Hard or Soft	If FP1 or 2 Sensor Err
Fault-CritComErr	19	No	Auto	Any critical com error. Auto reset upon condition removal	
ASB	ASB High Gas Concentration	81	Yes	Auto	High refrigerant gas concentration detected by ASB and gas sensor.
	ASB Sensor Problem	82	Yes	Auto	Gas sensor has issued a fault, lost communication, internal error
	Invalid System Config	97	Yes	Auto	ABC has not been configured for Refrigerant type, disch pr sensor type, or suct press sens.

**Note:**

\*All codes >11 use long flash for tens digit and short flash for the ones digit. 20, 30, 40, 50 etc. will be skipped!  
Alert' is a noncritical sensor or function that has failed. Normal operation of the heat pump is maintained but service is desired at some point.

## Aurora Control System

Aurora now expands the Fault/Alarms in to several groups. Faults are system critical faults to the heat pump and will cause a Lockout. Some are retried 3 times before locking out while others lockout out immediately. Consult the Fault Retries table before lockout for details. Alarms are designed solely to alert the customer and the dealer to alarms designed as an input only to the Aurora system. These alarms are not system critical. Errors are sensor/hardware errors that although may not be system critical, may need serviced for optimal features.

**SafeMode** - the system is still operational during safemode.

### Summary Table of Faults, Alarm, and Errors

All lockouts and alarms are shown in the Status LED (LED1, Red) table with the associated codes visible on the thermostat, ABC Fault LED, and in text in the AID Tool.

#### Aurora Fault Codes (ABC-Red LED)

These fault codes generally will affect the operation of the heat pump and will cause a lockout.

**E1, Fault Input** - A Y1/Y2 style thermostat is providing a non-normal sequence of signals possibly caused by a bad thermostat wire or connection.

**E2, High Pressure** - Fault is recognized when the Normally Closed High Pressure Switch, P4-9/10 opens, no matter how momentarily. The High Pressure Switch is electrically in series with the Compressor Contactor and serves as a hardwired limit switch if an overpressure condition should occur.

**E3, Low Pressure** - Fault is recognized when the Normally Closed Low Pressure Switch, P4-7/8 is continuously open for 30 seconds. Closure of the LPS any time during the 30 second recognition time restarts the 30 second continuous open requirement. A continuously open LPS shall not be recognized during the 2 minute startup bypass time.

**E3, Loss of Charge** - Fault is recognized when the Normally Closed Low Pressure Switch, P4-7/8 is open prior to the compressor starting.

**E4, Freeze Detection-Air Coil** - Air Coil Freeze Detection will use the FP2 input to protect against ice formation on the air coil. The FP2 input will operate exactly like FP1 except that the set point is 30 degrees and is not field adjustable.

**E5, Freeze Detection-Coax** - Set points shall be either 30°F or 15°F. When the thermistor temperature drops below the selected set point, the control shall begin counting down the 30 seconds delay. If the thermistor value rises above the selected set point, then the count should reset. The resistance value must remain below the selected set point for the

entire length of the appropriate delay to be recognized as a fault. This fault will be ignored for the initial 2 minutes of the compressor run time.

**E7, Condensate Overflow** - Fault is recognized when the impedance between this line and 24 VAC common or chassis ground drops below 100K ohms for 30 seconds continuously.

**E8, Over/Under Voltage Shutdown** - An over/under voltage condition exists when the control voltage is outside the range of 18 VAC to 30 VAC. If the over/under voltage shutdown lasts for 15 minutes, the lockout and alarm relay will be energized. Over/under voltage shutdown is self-resetting in that if the voltage comes back within range of 18 VAC to 30 VAC for at least 0.5 seconds, then normal operation is restored.

**E10, Compressor Monitoring** - Fault is recognized when the compressor has an open circuit, potential welded contactor.

**E11, FP1 Sensor Error** - Fault is recognized when the impedance between this line and 24 VAC common or chassis.

**E19, Critical Communication Error** - A critical communication error has occurred with a board that previously had been configured but now is not available for communication. Since this is critical to unit operation, the heat pump will be locked out with this fault displayed on the ABC board and the thermostat. The AID Tool should be used to view the configuration window and ascertain the status of all appropriate board communication. The fault displayed will be removed when the problem has been resolved or the unit is soft or hard reset.

**E81, ASB Leak Detected** - The gas sensor has detected a leak. The ASB will communicate the leak to the ABC control board. Compressor and auxiliary heat will be deactivated, and blower will come on.

**E82, ASB Sensor Problem** - The gas sensor has lost communication with the ASB board or has an internal error.

**E97, Invalid System Configuration** - ABC has not been configured for sensor or refrigeration type.

**Note:** E81, E82 and E97 are only used on units with mitigation.

# Aurora Control System

## Aurora Interface and Diagnostics (AID) Tool



The Aurora Interface and Diagnostics (AID) Tool is a device that is a member of the Aurora network. The AID Tool is used to troubleshoot equipment which uses the Aurora control via Modbus RTU communication. The AID Tool provides diagnostics, fault management and system configuration capabilities to the Aurora family of controls. An AID Tool is recommended, although not required. The AID Tool simply plugs into the exterior of the cabinet in the AID Tool port.

## ABC Control Board Layout

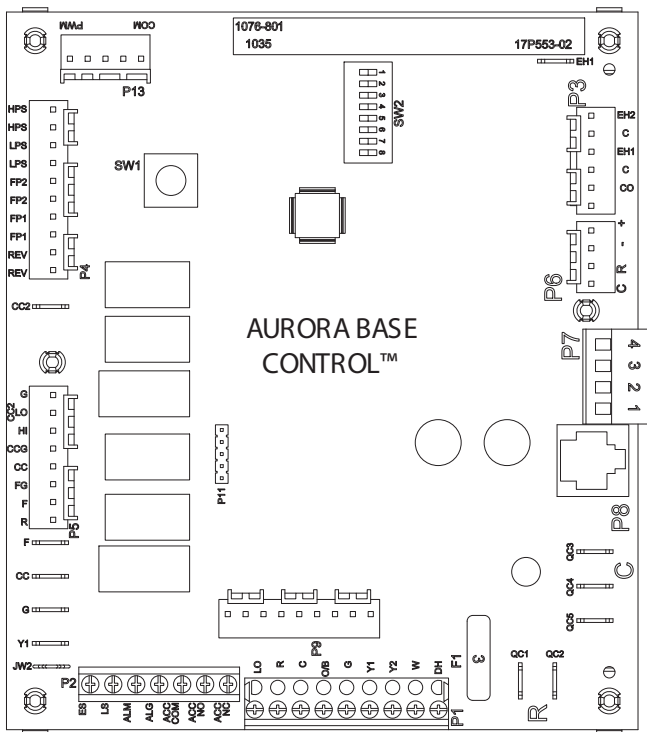

**Note:** The ASB Control Board and RDS sensor are only on units with mitigation.

## ASB Sensor Board

### Refrigerant Leak Detection

The Aurora control system uses the ASB control board to monitor the refrigerant sensor and determine when a fault condition requiring mitigation has been recognized and is active.

The ASB control will provide the indicator for an active refrigerant leak condition requiring mitigation in addition to the currently measured refrigerant level in ppm for each sensor connected to the ASB.

### Refrigerant Leak Mitigation

The refrigeration sensor will detect a leak if the LFL (Lower Flammability Limit) exceeds 13%. The ASB board will communicate the leak detection to the ABC control board. The ABC will deactivate the compressor, auxiliary heat and pump outputs. The system's blower will come on, and the system will continue to operate in this state until the ABC is no longer reporting a fault condition.

## ASB Control Board

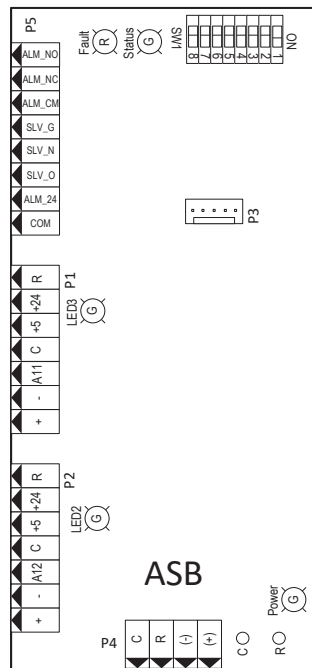

ASB Green Status LED	
OFF	Power Off
Slow Flash	Normal Operation
Fast Flash	ABC Loss Communication
ASB Red Fault LED	
OFF	Power Off
Slow Flash	Alarm
Fast Flash	Sensor Loss Communication

## RDS Refrigeration Detection Sensor

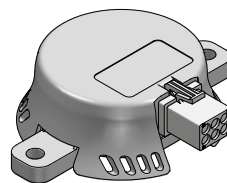

RDS Green Status LED	
Solid	Power Up / Self Test
Blinking	Normal Operation
RDS Red Fault LED	
Solid	Alarm State
Blinking	Sensor Fault

## Refrigerant Circuit Guideline

Symptom	Head Pressure	Suction Pressure	Compressor Amp Draw	Superheat	Subcooling	Air Temp. Differential	Water Temp. Differential
Under Charged System (Possible Leak)	Low	Low	Low	High	Low	Low	Low
Over Charged System	High	High	High	Normal	High	Normal/Low	Normal
Low Air Flow Heating	High	High	High	High/Normal	Low	High	Low
Low Air Flow Cooling	Low	Low	Low	Low/Normal	High	High	Low
Low Water Flow Heating	Low/Normal	Low/Normal	Low	Low	High	Low	High
Low Water Flow Cooling	High	High	High	High	Low	Low	High
High Air Flow Heating	Low	Low	Low	Low	High	Low	Low
High Air Flow Cooling	Low	High	Normal	High	Low	Low	Normal
High Water Flow Heating	Normal	Low	Normal	High	Normal	Normal	Low
High Water Flow Cooling	Low	Low	Low	Low	High	Normal	Low
Low Indoor Air Temperature Heating	Low	Low	Low	Normal	High	Normal	Normal/High
Low Indoor Air Temperature Cooling	Low	Low	Low	Normal/Low	High	Low	Low
High Indoor Air Temperature Heating	High	High	High	Normal/High	Normal/Low	Low	Normal
High Indoor Air Temperature Cooling	High	High	High	High	Low	Low	High
Restricted Expansion Device	High	Low	Normal/Low	High	High	Low	Low
Insufficient Compressor (Possible Bad Valves)	Low	High	Low	High	Normal/High	Low	Low
Scaled Coaxial Heat Exchanger Heating	Low	Low	Low	Normal/Low	High	Low	Low
Scaled Coaxial Heat Exchanger Cooling	High	High	High	Normal/Low	Low	Low	Low
Restricted Filter Drier	Check temperature difference (delta T) across filter drier.						

## Electrical Information

### General

Be sure the available power is the same voltage and phase as that shown on the unit serial plate. Line and low voltage wiring must be done in accordance with local codes or the National Electric Code, whichever is applicable.

### Unit Power Connection

Connect the incoming line voltage wires to L1 and L2 of the contactor as shown in Figure 13C for single-phase unit. Consult the Unit Electrical Data in this manual for correct fuse sizes.

Open lower front access panel. Remove ground fastener from bottom of control box (Figure 13B). Swing open control box (Figure 13A). Insert power wires through knockouts on lower left side of cabinet. Route wires through left side of control box and connect to contactor and ground (Figure 13C). Close control box and replace grounding fastener before unit start-up.

### Accessory Relay

A set of “dry” contacts has been provided to control accessory devices, such as water solenoid valves on open loop installations, electronic air cleaners, humidifiers, etc. This relay contact should be used only with 24 volt signals and not line voltage power. The relay has both normally open and normally closed contacts and can operate with either the fan or the compressor. Use DIP switch SW2-4 and 5 to cycle the relay with blower, compressor, or control a slow opening water valve. The relay contacts are available on terminals #1 and #3 for normally closed, and #2 and #3 for normally open on P2.

A second configurable accessory relay is provided on the AXB board, if installed. When powering high VA draw components such as electronic air cleaners or V type open loop water valves, R should be taken ‘pre-fuse’ from the ‘R’ quick connect on the ABC board and not the ‘post-fuse’ ‘R’ terminal on the thermostat connection. If not, blown ABC fuses might result.

### 208 Volt Operation

All 208/230 units are factory wired for 230 volt operation. For 208 volt operation, the red and blue transformer wires must be switched on terminal strip PB2.

### Pump Power Wiring

See Figure 14 for electrical connections from control box to pumps.

FC1/FC2 style flow centers with fixed speed pumps connect to PB1 in the control box. If using a variable speed pump it should be connected to L1 and L2 on the AXB.

# Electrical Information

**Figure 13A:**  
Wire access

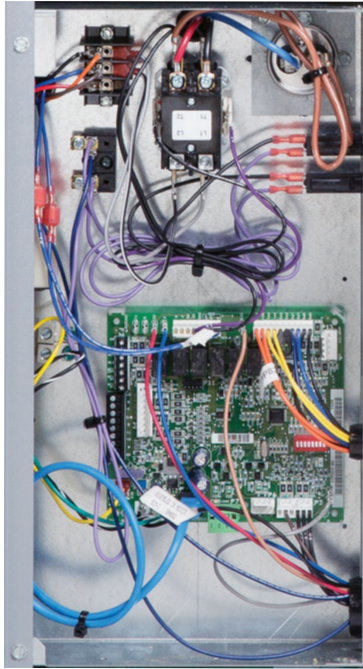

**Figure 13B:**  
Line Voltage 208-230/60/1 control box

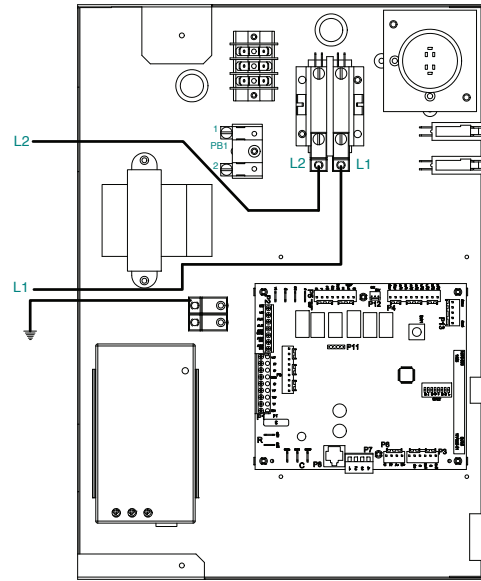

**Figure 13C:**  
Control Box with ASB Board

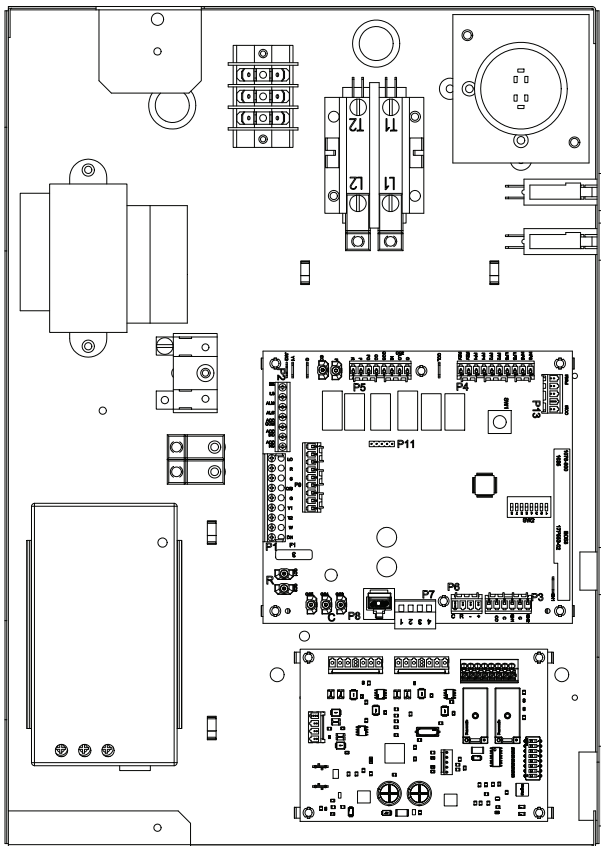

**Figure 14:**  
Pump Wiring 208-230/60/1

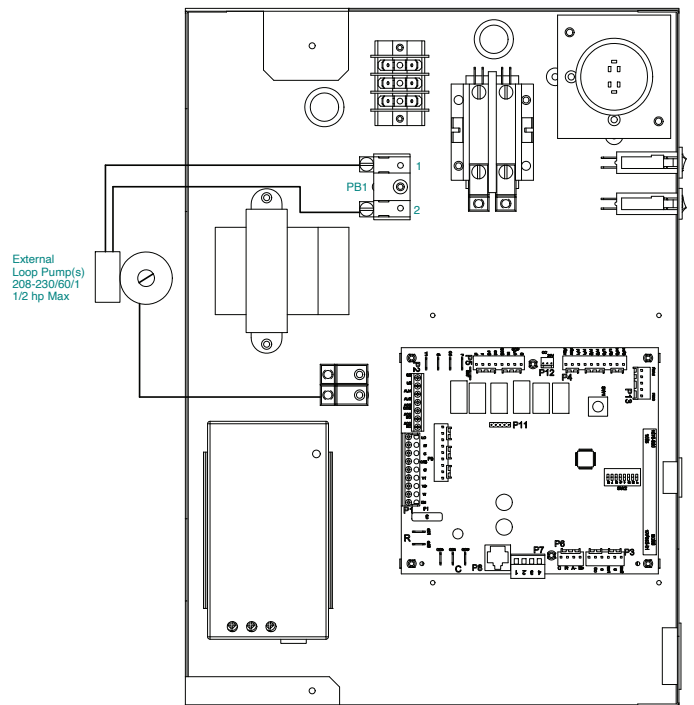

# Electrical Information - Flow Centers

## Fixed Speed Flow Center

The pump(s) will be connected to the terminals on PB1 in the unit electrical box as shown in Figure 14. The pumps will automatically be cycled as required by the unit or by a signal from another unit sharing the flow center (See Figures 5 and 6). Pumps are protected by circuit breakers (CB) shown in Figure 14.

**Figure 16: FCM and FCL Flow Center Wiring (Not Referenced)**

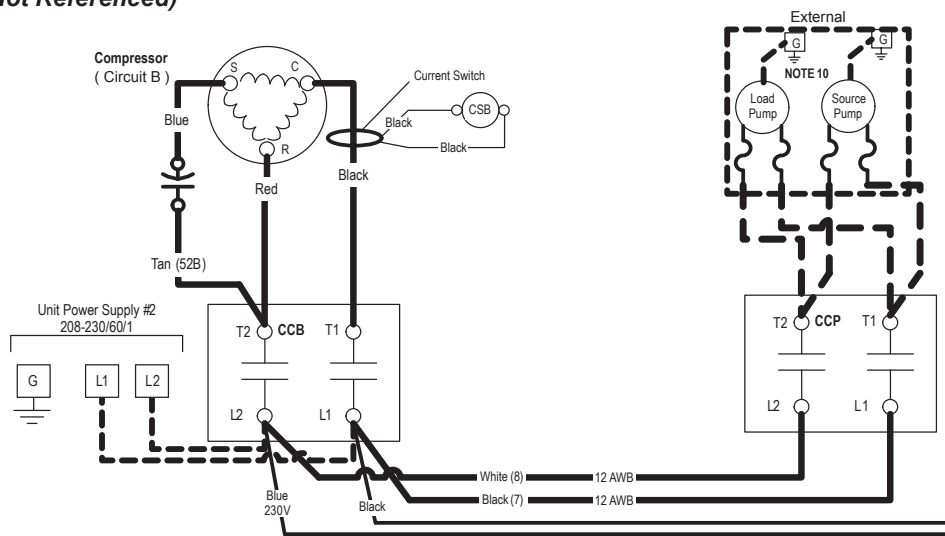

**NOTES:** FCM and FCL Flow Centers must be wired to a separate contactor (20 amp minimum). The HydroZone Accessory Control Box works best for this application.

# Electronic Thermostat Installation

Position the thermostat subbase against the wall so that it is level and the thermostat wires protrude through the middle of the subbase. Mark the position of the subbase mounting holes and drill holes with a 3/16-inch bit. Install supplied anchors and secure base to the wall. Thermostat wire must be 8-conductor (4 or 5 conductor for communicating thermostats), 20-AWG (minimum) wire. Strip the wires back 1/4-inch (longer strip lengths may cause shorts) and insert the thermostat wires into the connector as shown. Tighten the screws to ensure secure connections. The thermostat has the same type connectors, requiring the same wiring. See instructions enclosed in the thermostat for detailed installation and operation information. The W1 terminal on TPCM32U03A and TPCM32U04A communicating thermostats may be hard wired to provide aux/emergency heat in the event communication is lost between the thermostat and the ABC microprocessor.

**NOTE:** Aurora Base Control (ABC) DIP switch SW2-7 is required to be in the "OFF" position for the control to operate with FaultFlash or ComforTalk thermostats. SW2-7 in the "ON" position configures the control to operate with typical thermostats (continuous lockout signal). There must be a wire connecting Y2 on the Aurora controller to 2nd stage compressor on the thermostat for proper operation. SW2-7 DIP switch position is not relevant with communicating thermostats.

**Figure 21: Thermostat Wiring (Y1 Style Signals)**

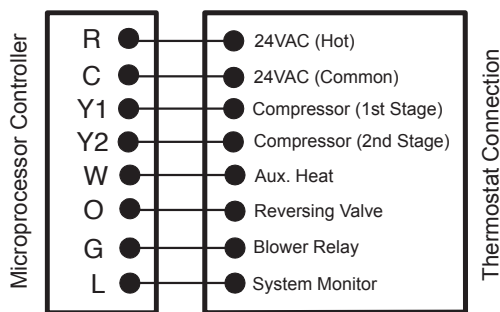

**Figure 22: Thermostat Wiring (Communicating Style Signals)**

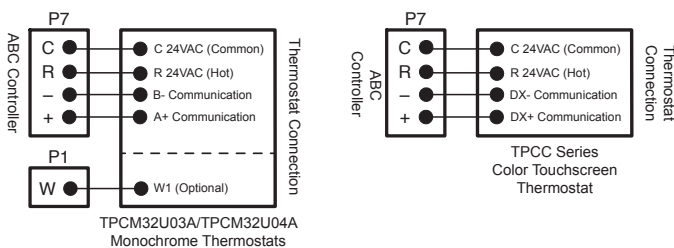

## Closed Loop Ground Source Systems

Once piping is completed between the unit, pumps and the ground loop, final purging and charging of the loop is required. A flush cart (or a 1.5 HP pump minimum) is needed to achieve adequate flow velocity in the loop to purge air and dirt particles from the loop itself. A filter **MUST** be used when flushing a loop. The standard 100 micron filter bag (LFC-F100M) is acceptable for capturing relatively large debris such as pipe shavings, gravel, and medium sand particles. In certain installation locations other smaller materials such as fine sand, silt, and clay can be less than 75 microns. For these smaller particles the use of the 1 micron filter bag is required (LFC-F1M). It is also recommended to run the flush cart with the 1 micron filter bag for at least 30 minutes. Antifreeze solution is used in most areas to prevent freezing. Flush the system adequately to remove as much air as possible then pressurize the loop to a static pressure of 40-50 psi (summer) or 50-75 psi (winter). This is normally adequate for good system operation. Loop static pressure will fluctuate with the seasons. Pressures will be higher in the winter months than during the cooling season. This fluctuation is normal and should be considered when initially charging the system.

**Figure 7: Closed Loop Ground Source Application**

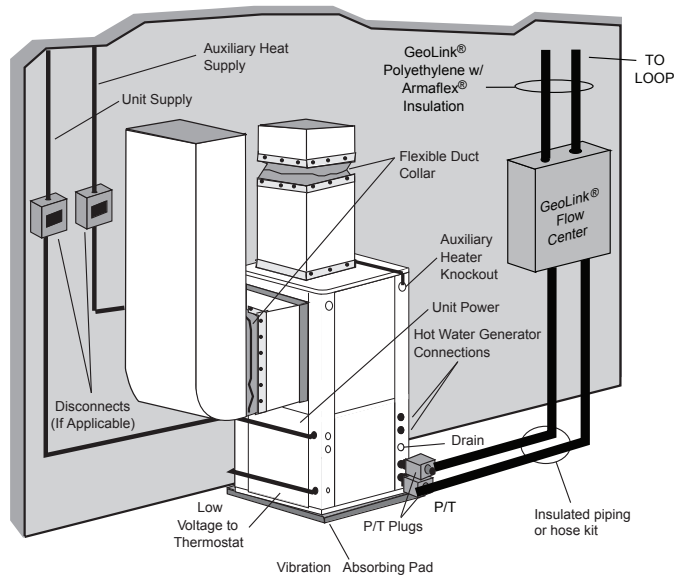

**NOTE:** Additional information can be found in Flow Center installation manual and Flush Cart manual.

## Multiple Units on One Flow Center

When two heat pumps are connected to one loop pumping system, follow Figure 8. Installer will be required to supply fuses, two relays, and wiring. It is recommended that water solenoid valves be installed on heat pumps that share a flow center. This is to allow water flow through only the heat pump that has a demand. Circulating fluid through a heat exchanger of a system that is not operating could be detrimental to the long-term reliability of the compressor.

**Figure 8: Primary/Secondary Wiring with Aurora Base Control (no AXB Board)**

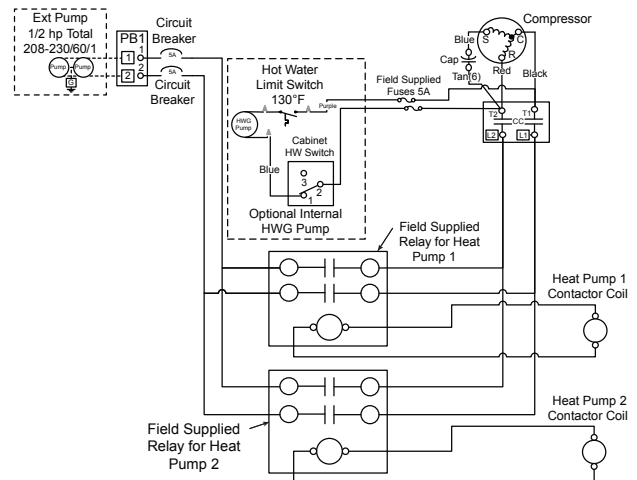

# Open Loop Ground Water Systems

Typical open loop piping is shown below. Always maintain water pressure in the heat exchanger by placing water control valves at the outlet of the unit to prevent mineral precipitation. Use a closed, bladder-type expansion tank to minimize mineral formation due to air exposure. Ensure proper water flow through the unit by checking pressure drop across the heat exchanger and comparing it to the figures in unit capacity data tables in the specification catalog. 1.5-2 gpm of flow per ton of cooling capacity is recommended in open loop applications.

Discharge water from the unit is not contaminated in any manner and can be disposed of in various ways, depending

on local codes, i.e. recharge well, storm sewer, drain field, adjacent stream or pond, etc. Most local codes forbid the use of sanitary sewer for disposal. Consult your local building and zoning departments to assure compliance in your area.

**NOTE:** For open loop/groundwater systems or systems that do not contain an antifreeze solution, set SW2-Switch #1 to the "WELL" (30°F) position. (Refer to the DIP Switch Settings table in the Aurora Control section.) Slow opening/closing solenoid valves (type V) are recommended to eliminate water hammer.

**Figure 9a: Open Loop Solenoid Valve Connection Option**  
Typical quick operating external 24V water solenoid valve (type PPV100 or BPV100) wiring.

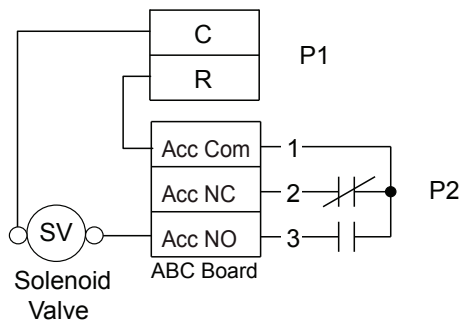

**NOTE:** SW2-4 and SW2-5 should be "OFF" to cycle with the compressor.

**Figure 9b: Open Loop Solenoid Valve Connection Option**  
Typical slow operating external 24V water solenoid valve (type V) wiring.

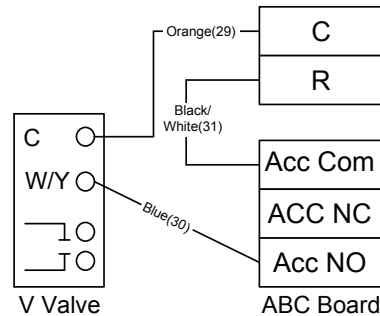

**NOTE:** SW2-4 should be "ON" and SW2-5 should be "OFF" when using a slow opening (V) water valve.

**Figure 10: Open System - Groundwater Application**

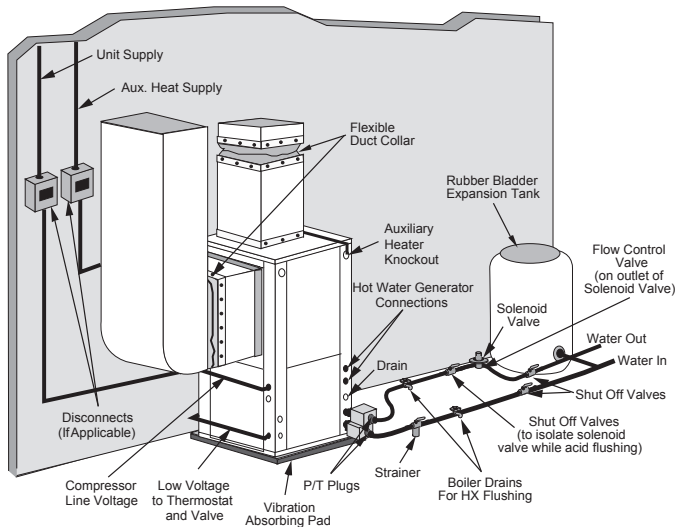

**Figure 9c:** Wiring diagram for dual water valve installations, one type V slow operating solenoid and one BPV100/PPV100 quick operating solenoid.

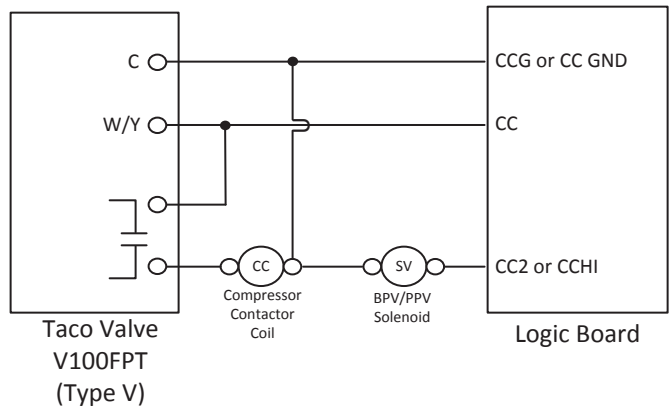

**Note:** SW2-4 should be 'ON' and SW2-5 should be 'OFF'.

## Compressor & Thermistor Resistance

Model	Compressor Model No.	208-230/60/1	
		Run	Start
024	YAS20K1E-PFV	0.99 - 1.14	1.54 - 1.77
036	YAS30K1E-PFV	0.67 - 0.78	1.37 - 1.57
048	YAS40K1E-PFV	0.41 - 0.47	1.54 - 1.78
060	YAS51K1E-PFV	0.35 - 0.41	1.34 - 1.55
072	YAS60K1E-PFV	0.31 - 0.35	1.30 - 1.50

1/30/24

Thermistor Temperature (°F)	Microprocessor Resistance (Ohms)
5	75757-70117
14	57392-53234
23	43865-40771
32	33809-31487
41	26269-24513
50	20570-19230
59	16226-15196
68	12889-12093
77	10310-9688
86	8300-7812
95	6723-6337
104	5480-5172
113	4490-4246
122	3700-3504
131	3067-2907
140	2554-2424
149	2149-2019

## Reference Calculations

Heating Calculations: $\text{LWT} = \text{EWT} - \frac{\text{HE}}{\text{GPM} \times 500^*}$	Cooling Calculations: $\text{LWT} = \text{EWT} + \frac{\text{HR}}{\text{GPM} \times 500^*}$
--	--

**NOTE:** \* When using water.

## Legend

### Abbreviations and Definitions

HWR = Hot Water Return

HWS = Hot Water Supply

CWR = Cold Water Return

CWS = Cold Water Supply

HVR = Heat Recovery Return

HVS = Heat Recovery Supply

HVP = High Voltage Panel

LVP = Low Voltage Panel

TC = Total Cooling Capacity in MBTUH

MBTUH = Thousands of British Thermal Units per hour

LWT = Leaving Water Temperature

EWT = Entering Water Temperature

EER = Energy Efficiency Ratio (TC/kW)

COP = Coefficient of Performance (HC/kW x 3.413)

PSI = Pressure drop in pounds per square inch

HC = Heating Capacity in MBTUH

HE = Heat of Extraction in MBTUH

kW = kilowatt

ft hd = pressure drop in feet of head

HR = Heat of Rejection

## Preventative Maintenance

Proper maintenance is very important to obtain optimum performance and longevity for the heat pump system. It is best to establish a periodic maintenance schedule with the installer so the heat pump system can be checked regularly.

### Water Coil Maintenance

1. Keep all air out of the water. An open loop system should be checked to ensure that the well head is not allowing air to infiltrate the water line. Lines should always be airtight.
2. Keep the system under pressure at all times. It is recommended in open loop systems that the water control valve be placed in the discharge line to prevent loss of pressure during off cycles. Closed loop systems must have positive static pressure.

**NOTE:** On open loop systems, if the installation is in an area with a known high mineral content (125 PPM or greater) in the water, it is best to establish with the owner a periodic maintenance schedule so the coil can be checked regularly. Should periodic coil cleaning be necessary, use standard coil cleaning procedures which are compatible with the heat exchanger and copper water lines. Generally, the more water flowing through the unit the less chance for scaling. However, flow rates above 3gpm/ton may erode the heat exchanger or water lines, due to high water velocity or system debris.

### Other Maintenance

#### Filters

Filters must be clean to obtain maximum performance. They should be inspected monthly under normal operating conditions and be replaced when necessary. Units should never be operated without a filter. Operating the system without a filter or with a dirty filter could affect the longevity of the heat pump.

### Condensate Drain

In areas where airborne bacteria produce a slime in the drain pan, it may be necessary to treat chemically to minimize the problem. The condensate drain can pick up lint and dirt, especially with dirty filters. Inspect twice a year to avoid the possibility of overflow.

### Blower Motors

ECM blower motors are equipped with sealed ball bearings and require no periodic oiling.

### Hot Water Generator Coil

See Water Coil Maintenance section above.

### Air Coil

The air coil must be cleaned to obtain maximum performance. Check once a year under normal operating conditions and, if dirty, brush or vacuum (with a brush attachment) clean. Care must be taken not to damage the aluminum fins while cleaning.



**CAUTION: Fin edges are sharp.**

## Replacement Procedures

### Obtaining Parts

When ordering service or replacement parts, refer to the model number and serial number of the unit as stamped on the serial plate attached to the unit. If replacement parts are required, mention the date of installation of the unit and the date of failure, along with an explanation of the malfunctions and a description of the replacement parts required.

### In-Warranty Material Return

Material may not be returned except by permission of authorized warranty personnel. Contact your local distributor for warranty return authorization and assistance.

## Troubleshooting

### Aurora Control System

**NOTE:** Refer to the Aurora Base Control Application and Troubleshooting Guide and the Instruction Guide: Aurora Interface and Diagnostics (AID) Tool for additional information.

To check the unit control board for proper operation:

1. Disconnect thermostat wires at the control board.
2. Jumper the desired test input (Y1, Y2, W, O or G) to the R terminal to simulate a thermostat signal.
3. If control functions properly:
  - Check for thermostat and field control wiring (use the diagnostic inputs mode).
4. If control responds improperly:
  - Ensure that component being controlled is functioning (compressor, blower, reversing valve, etc.).
  - Ensure that wiring from control to the component is correct.
  - Refer to the Aurora Base Control Application and Troubleshooting Guide and the Instruction Guide: Aurora Interface and Diagnostics (AID) Tool for additional information.

### Refrigerant Systems

To maintain sealed circuit integrity, do not install service gauges unless unit operation appears abnormal. Compare the change in temperature on the air side as well as the water side to the Unit Operating Parameters tables. If the unit's performance is not within the ranges listed, and the airflow and water flow are known to be correct, gauges should then be installed and superheat and subcooling numbers calculated. If superheat and subcooling are outside recommended ranges, an adjustment to the refrigerant charge may be necessary.

TXVs are factory set to a specific superheat; however, the superheat can be adjusted if needed. To adjust the TXV to other superheat settings:

1. Remove the seal cap from the bottom of the valve.
2. Turn the adjustment screw clockwise to increase
3. Once the proper superheat setting has been achieved, replace and tighten the seal cap.

**NOTE:** Refrigerant tests must be made with hot water generator turned "OFF". Verify that air and water flow rates are at proper levels before servicing the refrigerant circuit.

## Aurora Interface Diagnostic (AID) Tool

### Aurora Input-Output Diagnostics



Troubleshooting the Aurora logic board can be accomplished using nothing more than a couple of jumper wires and a volt meter. The process can be simplified with the use of the Aurora Interface Diagnostic Tool (AID Tool). The AID Tool allows the user to see lockout and fault history information, thermostat inputs, sensor inputs, system outputs, timer, etc.

### Aurora ABC Checkout

Before replacing the Aurora ABC control board the proper troubleshooting steps must be taken to ensure that the board is the root cause. On the following pages are several flow charts that will assist in checking the control board. If it is found that the control board is faulty, contact technical services for a replacement part.

Blower Speed Selection Number	PWM %	Dehumidification PWM %
1	2	2
2	11	3
3	19	9
4	31	20
5	41	28
6	52	37
7	60	44
8	68	51
9	78	59
10	89	69
11	95	74
12	98	76

### LED Displays

Slow Flash = 1 second on and 1 second off

Fast Flash = 100 ms on and 100 ms off

Flash Code = 100 ms on and 400 ms off with a 2 second pause between packages

### SW1 Operation

Holding SW1	Description of Operation	LED
2 to 5 sec	Enter Test Mode	Green LED Slow Flash
5 to 10 sec	Enter ECM Configure Mode	Yellow LED Off
50 to 60 sec	Reset Configure Mode (default)	Yellow LED Off
> 60 sec	SW1 Operation Cancel	Yellow LED Back to Normal

“SW1 operation cancel,” holding SW1 for longer than 60 seconds operation will be cancelled. Yellow LED will go back to normal operation.

### Fault Retries Before Lockout

Type of Fault	Total Tries Before Lockout
High Pressure	3 Retries
Low Pressure	3 Retries
Freeze Detection 1 - (Coax)	3 Retries
Freeze Detection 2 - (Air coil)	3 Retries
Condensate Overflow	3 Retries
Over/Under Voltage Shutdown	No Lockout
Compressor Monitor	No Retry
Freeze Detection Sensor Error (Sensor is out of range)	No Retry

## Preliminary Checkout Procedure

Troubleshooting liquid source heat pumps with Aurora controls is an easy and straight forward process. Most service problems are related to water flow (insufficient or too cold). Also, most service problems can be fixed without connecting refrigerant manifold gauges.

The first item to check is system performance which can be done in six steps. Before beginning make sure the hot water generator pump is disconnected.

**STEP 1:** Check and/or set source water flow. Refer to the install manual for the specific piece of equipment’s correct water flow setting.

**STEP 2:** Check the temperature difference through the coaxial heat exchanger and compare to the Operating Parameters table in the equipment install manual.

**STEP 3:** Check the air temperature rise/drop and compare to the Operating Parameters table in the equipment’s installation manual.

**STEP 4:** If the first three steps check out, perform a heat of extraction/rejection test as described in the Water Side Analysis: Heat of Extraction/Rejection section to confirm proper operation.

**STEP 5:** If any or all of the above steps do not check out, be sure that the air coil and filter are clean.

**STEP 6:** Check superheat and subcooling by placing refrigeration gauges on the unit. Compare superheat and subcooling values with the charts in the equipment installation manual.

If the above six steps do check out, it would be safe to assume that the unit is performing well and the problem must lie elsewhere, i.e. excessive heat loss/gain in the structure or duct system, (undersized duct and/or registers, etc.)

If you suspect a specific problem, refer to the Table of Contents and select the reference that most closely matches the situation encountered. If problems persist after completing the preliminary checkout procedure, refer to the Troubleshooting Checklist. Select the problem which is closest to the situation you have encountered.

## Troubleshooting Checklist

### Equipment will not start or operate

- Follow the troubleshooting flow charts to find root cause.

### High pressure lockout in the heating mode

- Check for air flow interruption from one or more of the following: inoperative blower, dirty filters or air coil, blocked return air grille, closed or blocked supply registers, restricted supply or return duct, zone dampers, etc. If airflow is suspected as being a problem, make a quick check using the following example: Velocity in a supply duct should not exceed 1000 fpm and 700 fpm in return ducts. For this example we will use an model 038 which has a maximum rating of 1500 cfm at 0.50 static (Refer to the blower performance tables in the install manual for your particular piece of equipment). Using the formula: Area in square feet equals quantity in cfm divided by velocity in fpm ( $A = \text{cfm}/\text{fpm}$ ), 1.57 sq. ft. is needed for the supply duct and 2.14 sq. ft. is needed for the return duct. Refer to the troubleshooting flow charts if a problem with the blower motor or logic board is suspected.
- Check for blocked or seized expansion device.
- Make sure the discharge pressure is within the operating range shown in this product manual.
- The unit may be overcharged; check superheat and sub cooling. If this problem is verified, recharge using approved methods.

### High pressure lockout in the cooling mode

- Water flow may be restricted or inadequate. Verify in accordance with the pressure drop tables shown in product install manual. Also, look for the following: solenoid valve may not be opening on well water units, pump(s) may be inoperative in the flow center, debris may be blocking coil (back flush using at least 20 PSI), or air may be in the loop (flush loop).
- Water to refrigerant heat exchanger may be fouled with debris. If so, back flush with at least 20 psi of water pressure.
- If mineral accumulation is evident, clean the heat exchanger with acid.
- Entering air temperature may be too high. Equipment is designed for a maximum of 85°F DB and 71°F WB.
- Check for a seized or blocked expansion device.
- The unit may be overcharged; check superheat and sub cooling. If this problem is verified, recharge using approved methods.

### Low pressure lockout in heating mode

- If equipment is installed in a low temperature area (below 50°F), install a crankcase heater, then protect the unit from the elements.
- Water flow may be restricted or inadequate. Verify in accordance with the pressure drop tables shown in this product manual. Also, look for the following: solenoid valve may not be opening on well water units, pump(s) may be inoperative in the flow center, debris may be blocking coil (back flush using at least 20 PSI), or air may be in the loop (flush loop).
- Check for a seized or blocked expansion device.

- Return air temperature may be below 50°F. Block off air coil temporarily to improve flow of refrigerant through the system. Air below 50°F cannot be tolerated on a continuing basis. Correct the problem.
- Refrigerant may be low. Check for leaks, reclaim refrigerant, repair if necessary, recharge using approved methods.

### Low pressure lockout in the cooling mode

- Check for inadequate air flow. Follow the same procedure as shown for a high pressure lockout in the heating mode.
- Check for a seized or blocked expansion device.
- Refrigerant charge may be low.

### Water flow lockout in either the heating or cooling mode

- Water flow may be restricted or inadequate. Verify in accordance with the pressure drop tables shown in product install manual. Also, look for the following: solenoid valve may not be opening on well water units, pump(s) may be inoperative in the flow center, debris may be blocking coil (back flush using at least 20 PSI), or air may be in the loop (flush loop).
- Disconnect freeze sensor from control and measure the resistance. Cross reference with the Thermistor Data table.

### Condensate over flow lockout in either the heating or cooling mode

- Make sure the drain line pitches away from the unit. Install a vertical vent on horizontal drain lines over six feet long. Clean condensate pan and be sure outlet and drain line from the condensate pan is clear.

### Reversing valve does not operate

- Disconnect solenoid and check for continuity across coil. Replace coil if continuity is not found.
- If stuck reversing valve is suspected, restrict airflow in heating mode (to build pressure), then switch immediately to the cooling mode.

## Control Board Troubleshooting Steps

### 1) General Check

- If any new device was installed, or any wiring was changed, check the connections to ensure the wiring is correct, and all the wires are in good condition.
- Verify all the plugs are securely connected and in good condition.
- Check the DIP switch (SW2) positions are correct.
- Measure 24 VAC between R and C. (The actual reading may be from 18 to 30 VAC). Check the incoming power and the power transformer if the R and C voltage reading is not correct.

### 2) No LEDs are On

- Check 24 VAC on board.
- Check the 3 amp fuse. Replace the fuse if needed.
- Verify transformer circuit breaker has not tripped if no low voltage is present.
- Disconnect the thermostat connection P1.
- Replace the Aurora base control board.

### 3) Red LED Flash Code

**Input Fault (Code 1)** – Indicates that both O and W input signals are present. Disconnect the thermostat connector from the ABC board and then cycle power to the board. If the fault does not reappear, then the problem is between the thermostat and the thermostat connector. Otherwise, replace the ABC board.

**High Pressure Fault (Code 2)** – Indicates the system pressure has exceeded 600 psi (R-454B) which may have been caused by low water flow in cooling, (check coaxial heat exchanger for mineral build-up) or low air flow in heating (check filters and coil for dirt build-up). Measure P4-9 and C is 24 VAC. If not, replace ABC. Check the heat pump refrigeration system. Cycle the power to reset the system. Measure P4-10 and C is 24 VAC. If not, replace the high pressure sensor.

**Low Pressure Fault (Code 3)** – Indicates low pressure switch has opened which may indicate a loss of system charge, system restriction, or frozen heat exchanger. Measure P4-7 and C is 24 VAC. If not, replace ABC. Check the heat pump refrigeration system. Cycle the power to reset the system. Measure P4-8 and C is 24 VAC. If not, replace the low pressure sensor. Refrigerant may be low. Check for leaks, reclaim refrigerant, repair if necessary, pump down and recharge the system to the quantity of refrigerant shown on the unit nameplate.

**Freeze Detection 1 Fault (Code 5)** – Indicates low or no water flow; low system charge; or faulty expansion device in heating mode. Make sure the DIP switch FP1 (SW2-1) selection matches the application. Measure the temperature on the refrigerant line next to the freeze detection thermistor. Disconnect the connector P4. Measure the resistance reading between P4-3, P4-4. Refer to the Thermistor Data table, find the corresponding temperature data. Compare the data with the temperature measurement from the refrigerant line. The temperature should be within +/- 2° F. If not, replace the thermistor.

Other items to check when troubleshooting a water flow lockout are superheat, water flow through the coaxial heat exchanger and antifreeze composition. High superheat in heating will lower the refrigerant line temperature where the freeze detection thermistor is located. In this case, check the expansion device. Closed loop systems are rated at 3 gpm/ton. If a closed loop system is running at less than 3 gpm/ton, the temperature difference between the refrigerant line and the actual leaving water temperature will be greater and could lead to possible water flow lockouts.

**Condensate Fault (Code 7)** – Indicates condensate water in the drain pan fills up and touches the spade terminal. Make sure the drain line pitches away from the unit. Install a vertical vent on horizontal drain lines over six feet long. Clean and be sure outlet and drain line from the condensate pan is clear. Jumper between R, Y2 and O to start 2nd stage cooling. Observe the water level in the drain pan. If the unit is locking out on condensate and the drain pan is dry, remove the condensate wire from the drain pan and tape it out of the way. Be careful to not ground the wire out because that will cause the unit to lockout on drain overflow. If the unit is still locking out, check the brown wire all the way back to the ABC for a short to ground. Remember that the condensate sensor is just a wire looking for a ground. If it touches any metal in the cabinet, the unit will see that as a drain fault. If removing the wire from the drain pan stopped the false drain lockouts, put the condensate sensor back in place in the drain pan. Pay close attention to how far the spade terminal sits down in the drain pan. If the terminal is pushed all the way down so that it is touching the bottom of the drain pan, this will cause a drain lockout if there is any trace of water. If the spade terminal fits loosely in the drain pan, spread the terminal open to make it fit snugly in the drain pan.

**Over/Under Voltage Shutdown Fault (Code 8)** – Indicates the control voltage is or had been outside the range of 18 to 30 VAC for more than 15 minutes. Using a voltage meter, check the incoming power line voltage is within + or – 25%. If not, there is a power line issue. Check the secondary of the control transformer with a voltage meter. The voltage should be 18 to 30 VAC. If not, replace the control transformer.

**Freeze Detection FP1 Sensor Fault (Code 11)** – Indicates the freeze detection sensor is out of range. Disconnect the connector P4. Measure the resistance reading between P4-3, P4-4. Refer to the Thermistor Data table, find the corresponding temperature data. Compare the data with the temperature measurement from the refrigerant line. The temperature should be within +/- 2° F. If not, replace the thermistor.

## Control Board Troubleshooting Steps cont.

### 4) Other Faults

#### **ECM Motor Will Not Start**

1. Measure the voltage output between P13-1 and P13-5. Reference the chart below for blower speed vs. voltage.

Blower Speed Selection Number	DC Volts
1	0.6 VDC
2	2.7 VDC
3	4.6 VDC
4	7.5 VDC
5	9.8 VDC
6	12.5 VDC
7	14.4 VDC
8	16.3 VDC
9	18.5 VDC
10	21.2 VDC
11	22.3 VDC
12	23.4 VDC

2. Measure the voltage from C to F terminals (P5-2). The reading should be 24VAC.

**Compressor First Stage Will Not Start** – Measure the voltage output between P5-4 and P5-5, P5-7 and P5-8. The reading should be 24 VAC. If 24 VAC is not present check transformer output, thermostat wiring, current fault status, etc.

**Compressor Second Stage Will Not Start** – Measure the voltage output between P5-6 and P5-8. The reading should be 24 VAC. If 24 VAC is not present, check DIP switch settings, thermostat operation, and thermostat wiring.

**PSC Motor Will Not Start** – Measure the voltage output between P5-2 and P5-3. The reading should be 24 VAC.

**No Alarm Output** – Measure the voltage output between P2-4 and C. The reading should be 24 VAC or a pulsed 24 VAC dependent on the selection of SW2-7. If SW2-8 is set for reheat, the alarm output will be used to control the hot gas reheat valve and will not show lockout information.

**Accessory Relay Does Not Operate** – Measure the continuity between P2-2 and P2-3. It should read closed when relay is engaged. If this is not correct, check SW2-4 and SW2-5 settings.

**No Lockout Output** – Measure the voltage output between P1-1 and C. The reading should be 24 VDC or a pulsed 24 VDC dependent on the selection of SW2-7. If voltage is not present, make sure the unit is in lockout and not fault retry.

**Auxiliary Heater Does Not Function** – Measure the voltage output between P3-1, P3-2, and P3-3, P3-4. The output should be 24 VDC. If voltage is not present, check thermostat operation and wiring.

**Loop Pump Does Not Start** – The loop pump is controlled by the AXB board. Check to make sure the control board is powered by taking a voltage reading across R and C to check for 24VAC. If 24VAC is not present check the wiring connections, 24VAC is supplied to the AXB through the harness connected to P9. Next check to make sure the ABC is attempting to run the compressor, the loop pump will only run when the ABC is commanding CC on, the pump slave input is active, or the AXB has lost communication with the ABC. Please refer to troubleshooting flow charts for additional checks on the loop pump.

### 5) Operation Modes

**Enter First Stage Heating** – Remove P1. Place a jumper between R and Y1.

**Enter Second Stage Heating** – Remove P1. Place a jumper between R, Y1 and Y2. This is for SW2-6 set to “OFF” position.

**Enter Third Stage Heating** – Remove P1. Place a jumper between R, Y1, Y2 and W.

**Enter First Stage Cooling** – Remove P1. Place a jumper between R, O and Y1.

**Enter Second Stage Cooling** – Remove P1. Place a jumper between R, O, Y1 and Y2.

**Enter Emergency Heating** – Remove P1. Place a jumper between R and W.

**Enter Blower Only Mode** – Remove P1. Place a jumper between R and G.

**Enter Reheat Mode** – Remove P1. Place a jumper between R and DH. (SW2-8 must be off)

These notes are for SW2-3 set to “ON” position.

# Control Board Troubleshooting Flow Charts

Use the following flow charts to aid in troubleshooting the control board.

## Compressor Will Not Start Without AID Tool

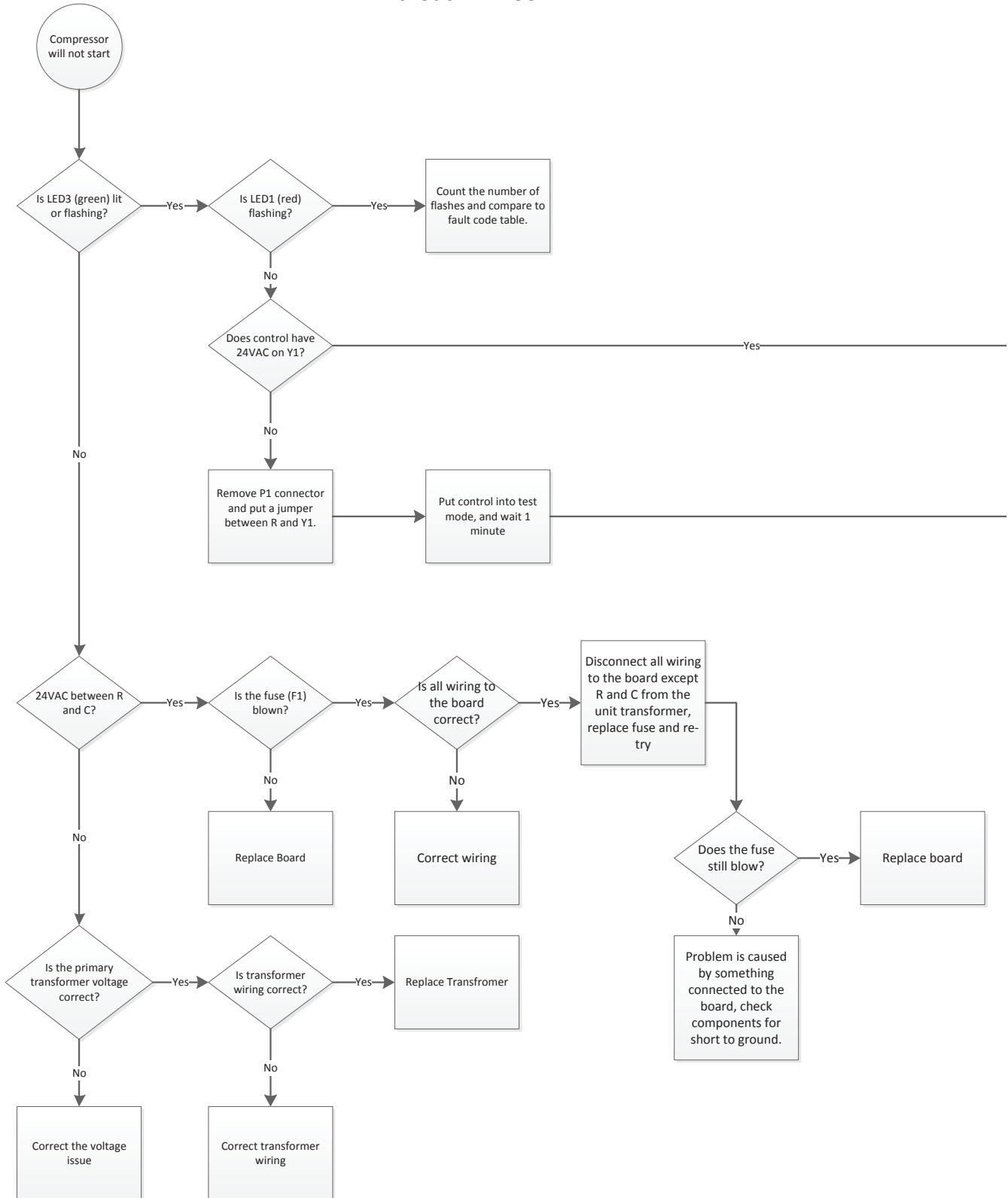

# Control Board Troubleshooting Flow Charts cont.

**Notes:**

1. When measuring 24VAC actual value may be between 18 and 30VAC.

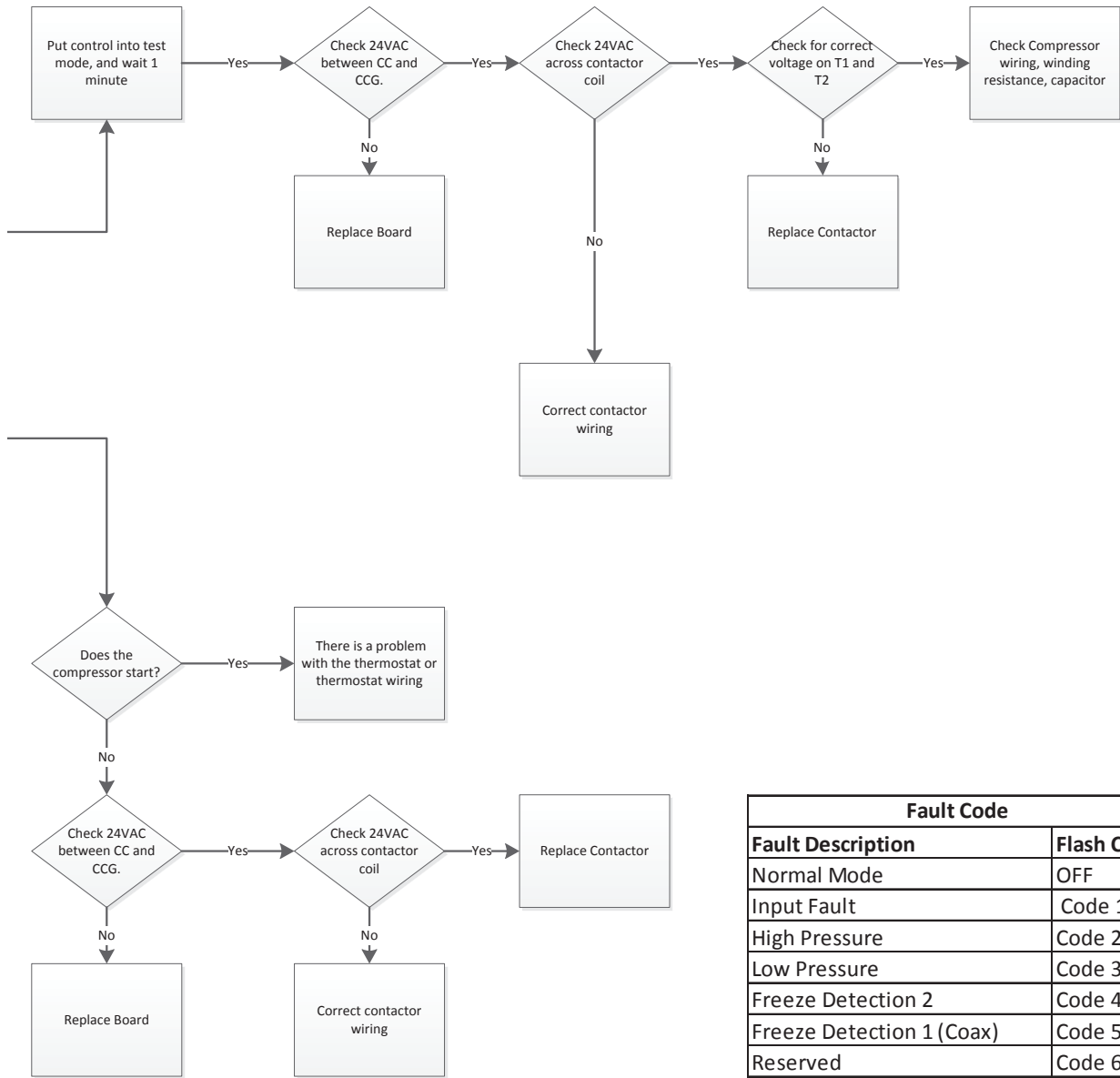

Fault Code	
Fault Description	Flash Code
Normal Mode	OFF
Input Fault	Code 1
High Pressure	Code 2
Low Pressure	Code 3
Freeze Detection 2	Code 4
Freeze Detection 1 (Coax)	Code 5
Reserved	Code 6
Condensate	Code 7
Over/Under Voltage	Code 8
Not Used	Code 9
Freeze Detection Sensor Error	Code 11

**NOTE:** Refer to the Control Board Troubleshooting Steps for fault descriptions.

# Control Board Troubleshooting Flow Charts cont.

## Compressor Will Not Start With AID Tool

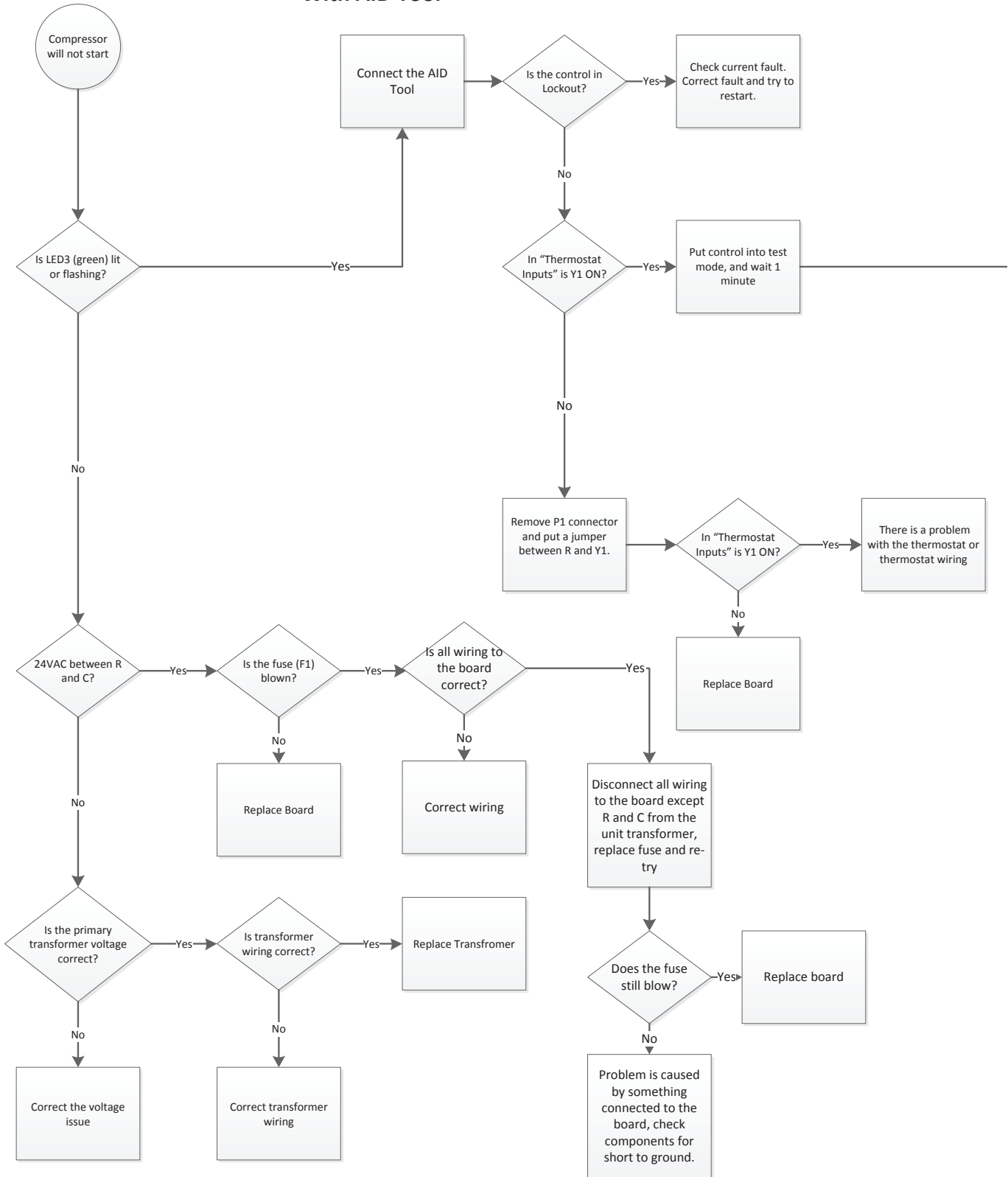

# Control Board Troubleshooting Flow Charts cont.

**Notes:**

1. When measuring 24VAC actual value may be between 18 and 30VAC.

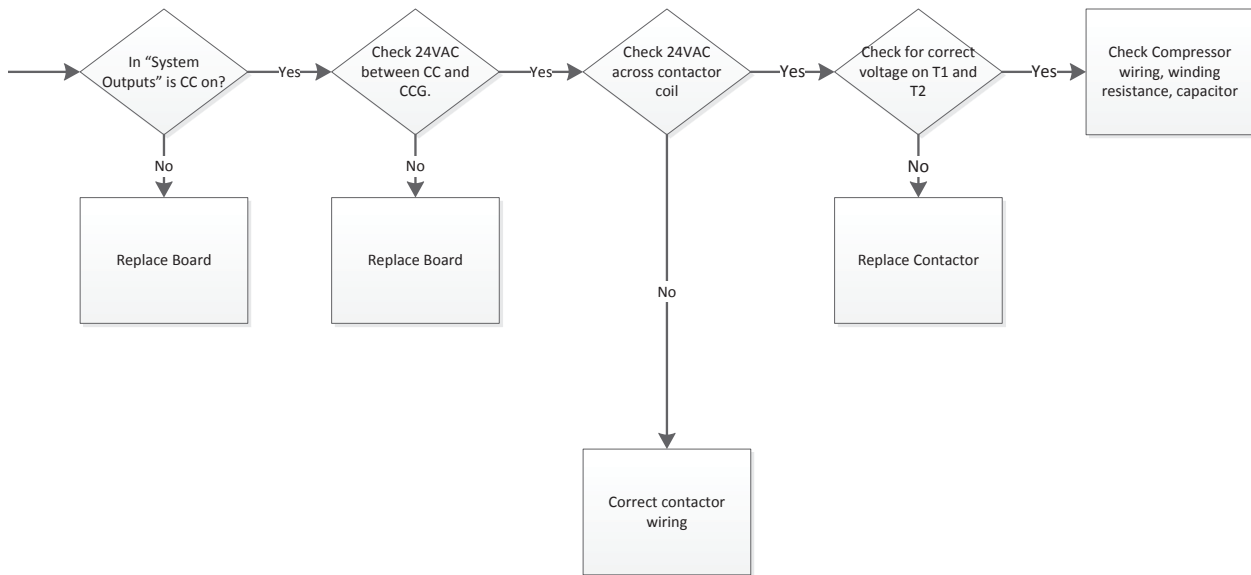

# Control Board Troubleshooting Flow Charts cont.

## ECM Blower Will Not Start With AID Tool



# Control Board Troubleshooting Flow Charts cont.

**Notes:**

1. When measuring 24VAC actual value may be between 18 and 30VAC.

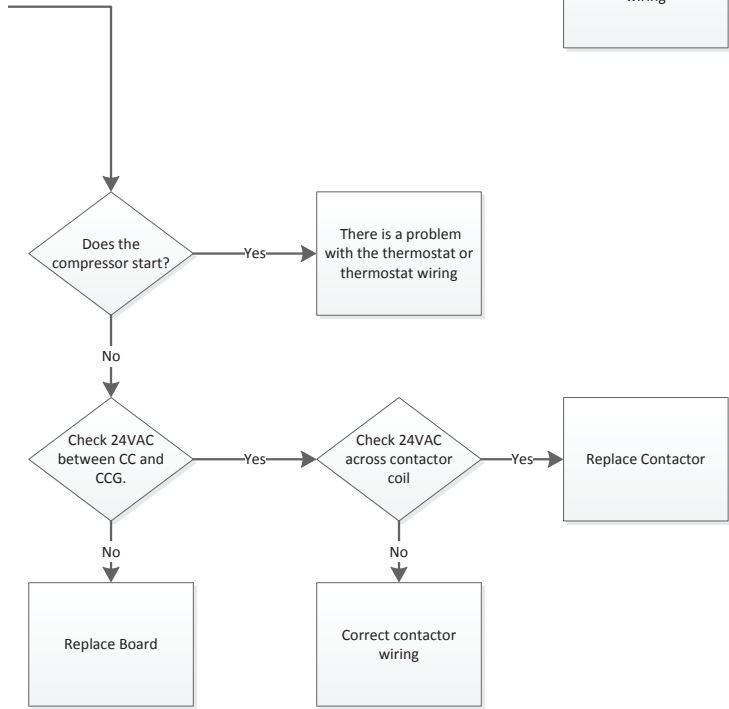
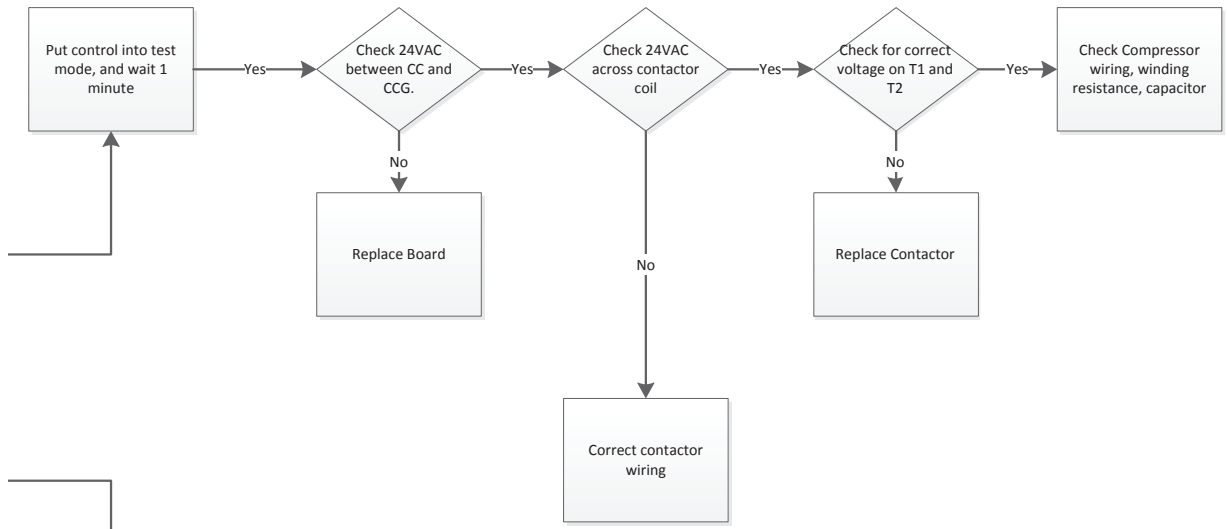

Fault Code	
Fault Description	Flash Code
Normal Mode	OFF
Input Fault	Code 1
High Pressure	Code 2
Low Pressure	Code 3
Freeze Detection 2	Code 4
Freeze Detection 1 (Coax)	Code 5
Reserved	Code 6
Condensate	Code 7
Over/Under Voltage	Code 8
Not Used	Code 9
Freeze Detection Sensor Error	Code 11

# Communicating Thermostat Troubleshooting Guide

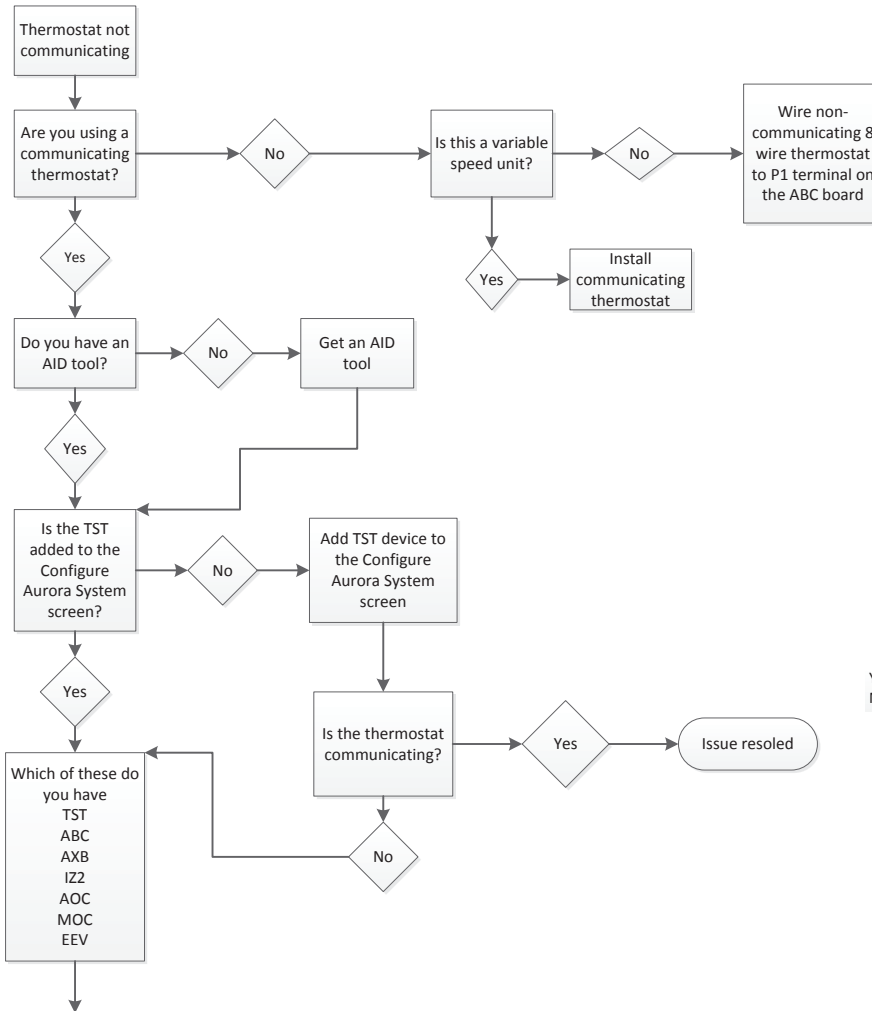

Configure Aurora System Screen

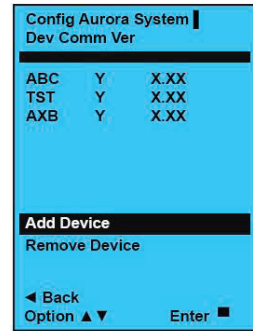

Single and Dual Capacity unit

Y – Active Communication  
 N – Device has been found, but communication has failed.

Continue to Next Page

# Communicating Thermostat Troubleshooting Guide cont.

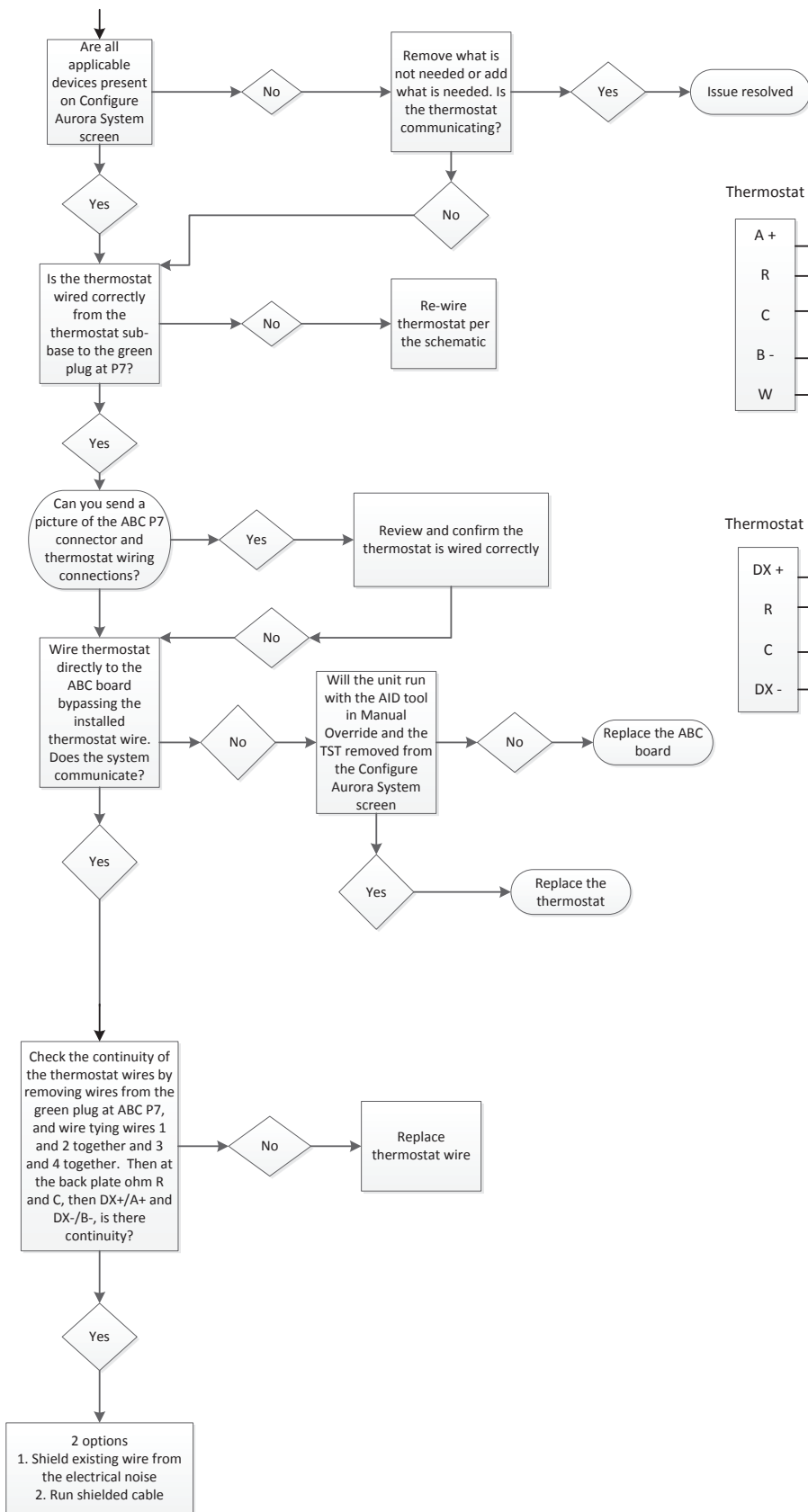

TPCM32U03A /TPCM32U04A

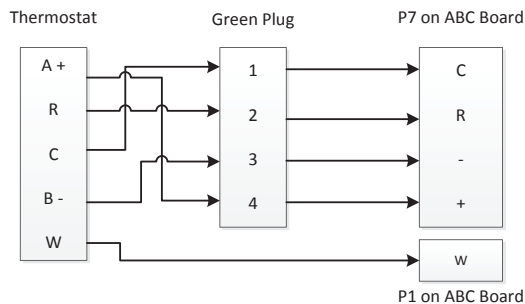

TPCC32U01

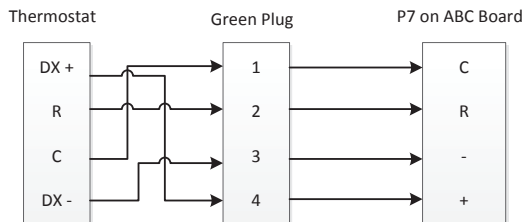

## Control Board Signals

### To Check for 24VAC between R and C

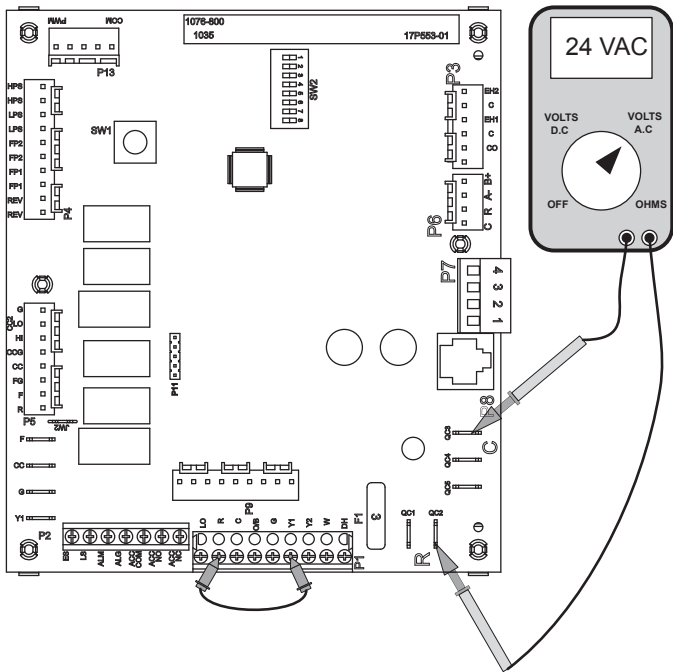

With power applied to the unit connect your Volt meter leads to “R” and “C” on the control board where the yellow and black/white transformer wires connect. The reading should be between 18VAC and 30VAC.

### To Check for 24VAC to Compressor Contactor

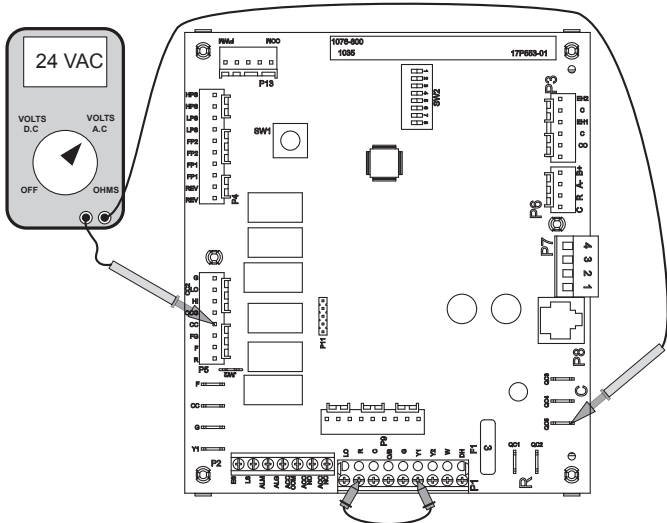

With the AID Tool go to the “Thermostat Inputs” Menu under “Diagnostics” and over-ride the “Y1” input to ON. If an AID Tool is not available remove the P1 connector to disconnect the thermostat from the board and place a jumper wire between “R” and “Y1” as shown. Apply power and put the board into test mode by holding SW1 for 2-5 seconds, the green LED will begin a slow flash. Connect your Volt meter leads to “CC” and “C”. After 1 minute the reading should be between 18 and 30VAC. If you have

a signal and the contactor is not pulled in, check voltage across the contactor coil. If you have voltage across the contractor coil, replace the contactor. If there is no voltage across the contactor coil, verify all wiring between the board and contactor. If you have no voltage between CC and C and the fault LED is not flashing, then replace the board.

### To Check Operation of the Reversing Valve Output

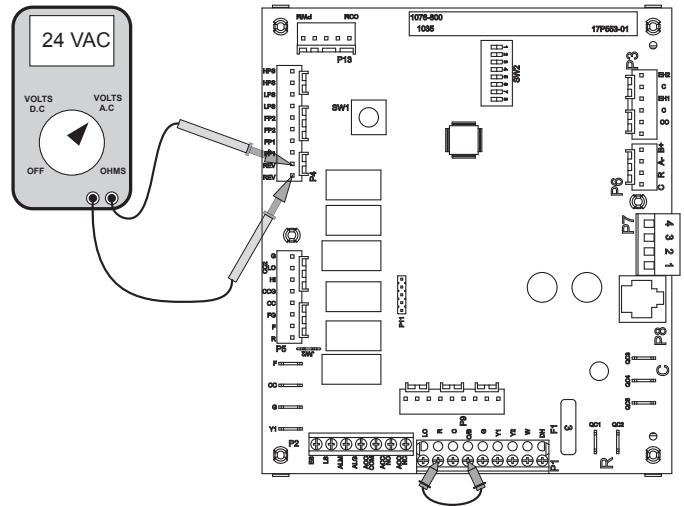

Make sure that SW2-3 is set to “ON”. With the AID Tool go to the “Thermostat Inputs” Menu under “Diagnostics” and over-ride the “O” input to ON. If an AID Tool is not available remove the P1 connector to disconnect the thermostat from the board and place a jumper wire between “R” and “O” as shown. Apply power and put the board into test mode by holding SW1 for 2-5 seconds, the green LED will begin a slow flash. Connect your Volt meter leads to the two “REV” pins on P4. The reading should be between 18 and 30VAC. If you have voltage and the reversing valve is not shifting, check voltage across the coil. If you have voltage across the reversing valve coil, but the valve does not shift the reversing valve coil may be bad. If there is no voltage across the coil, verify all wiring between the board and reversing valve. If no voltage is present on the two REV terminals then replace the board.

## Control Board Signals cont.

### To Check Operation of the Accessory Relay

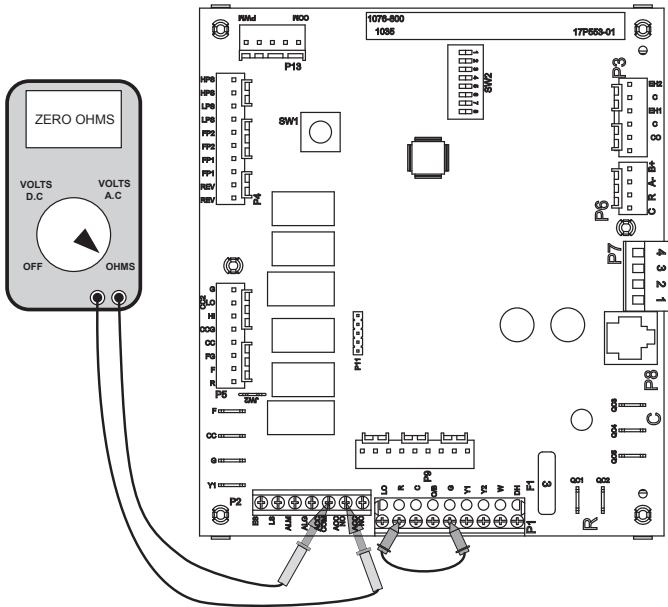

Make sure that SW2-4 and SW2-5 are both set to "ON". With the AID Tool go to the "Thermostat Inputs" Menu under "Diagnostics" and over-ride the "G" input to ON. If an AID Tool is not available remove the P1 connector to disconnect the thermostat from the board and place a jumper wire between "R" and "G" as shown. Apply power and put the board into test mode by holding SW1 for 2-5 seconds, the green LED will begin a slow flash. Connect your Ohm meter leads to the two "ACC COM" and "ACC NO" on P2. A reading of zero ohms indicates that the relay is switching and operating normally. A reading of infinity or open line indicates that the relay did not close and the board should be replaced.

### To Bypass the Safety Circuit and Engage the Compressor Contactor

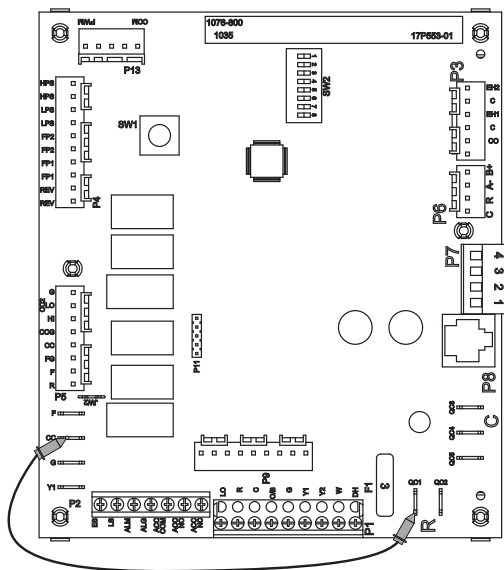

Put gauges on the unit to monitor high/low pressure. Place a jumper between "R" and "CC" as shown. **This will bypass the safety circuit and the compressor will run whether the board is calling for it or not.**

### To Check the Freeze Detection Thermistor (AID Tool Required)

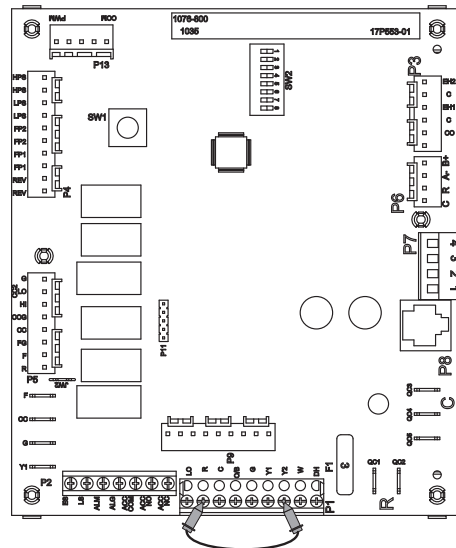

Disconnect the loop pumps so they will not run. Place a thermocouple on the refrigerant line next to the freeze detection thermistor. With the AID Tool go to the "Thermostat Inputs" Menu under "Diagnostics" and over-ride the "Y2" input to ON. If an AID Tool is not available remove the plug on P1 to disconnect the thermostat from the board. Place a jumper on "R" and "Y2" as shown. Apply power and put the board into test mode by holding SW1 for 2-5 seconds, the green LED will begin a slow flash. As the unit runs in second stage heating with the loop pump(s) not working, the lack of water flow will quickly bring down the temperature of the refrigerant line where the freeze detection thermistor is located. Watch the FP1 temperature reading on the AID Tool and compare it with the thermocouple reading. The thermocouple reading and FP1 reading should be within 2 degrees F of each other. If the thermistor is found to be out of calibration, replace the thermistor. Allowing the unit to continue to run will cause a freeze detection fault to occur. Remember, there is a two minute bypass delay and a 30 second recognition delay on the freeze detection input. This means that the compressor will not shut down during the first 2.5 minutes of run time regardless of how low the freeze thermistor reads.

Other items to check when troubleshooting a freeze detection lockout are superheat, water flow through the coaxial heat exchanger, and antifreeze composition. High superheat in heating will lower the refrigerant line temperature where the freeze protection thermistor is located. In this case, check the expansion device. Closed loop systems are rated at 3 gpm/ton. If a closed loop system is running at less than 3 gpm/ton, the temperature difference between the refrigerant line and the actual leaving water temperature will be greater and could lead to possible freeze detection lockouts.

## Control Board Signals cont.

### To Check the Condensate Sensor

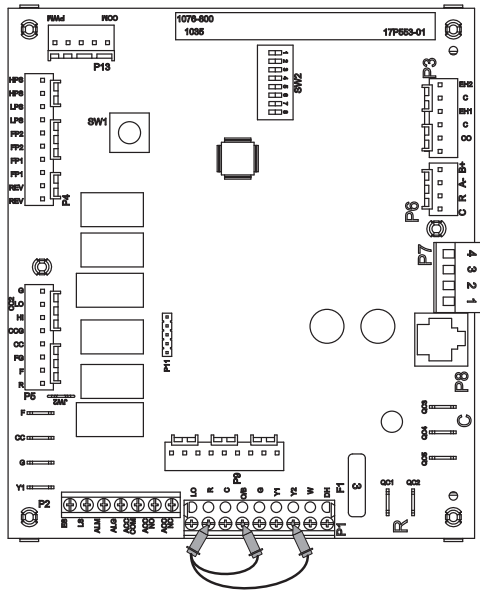

How it works: The condensate sensor is a three part system: a wire, air coil, and water in the drain pan. The wire (spade terminal) and air coil act like a normally open contact and the water acts as the switch. When water in the drain pan fills up and touches the spade terminal, the unit will fault on condensate.

Checking the Sensor: With the AID Tool go to the “Thermostat Inputs” Menu under “Diagnostics” and over-ride the “O” and “Y2” inputs to ON. If an AID Tool is not available remove the P1 connector to disconnect the thermostat from the board and place a jumper wire between “R”, “Y2”, and “O” as shown. Apply power and put the board into test mode by holding SW1 for 2-5 seconds, the green LED will begin a slow flash. Observe the water level in the drain pan. If the unit is locking out on condensate and the drain pan is dry, remove the condensate wire from the drain pan and tape it out of the way. Be careful not to ground the wire out because that will cause the unit to lockout on condensate over flow. If the unit is still locking out, check the brown wire all the way back to the logic board for a short to ground. Remember that the condensate sensor is just a wire looking for a ground. If it touches any metal in the cabinet, the unit will see that as a condensate fault.

If removing the wire from the drain pan stopped the false drain lockouts, put the condensate sensor back in place in the drain pan. Pay close attention to how far the spade terminal sits down in the drain pan. If the terminal is pushed all the way down so that it is touching the bottom of the drain pan, this will cause a condensate lockout if there is any trace of water in the drain pan. If the spade terminal fits loosely in the drain pan, spread the terminal open to make it fit snugly in the drain pan.

### To Check the ECM Blower Motor Enable Signal

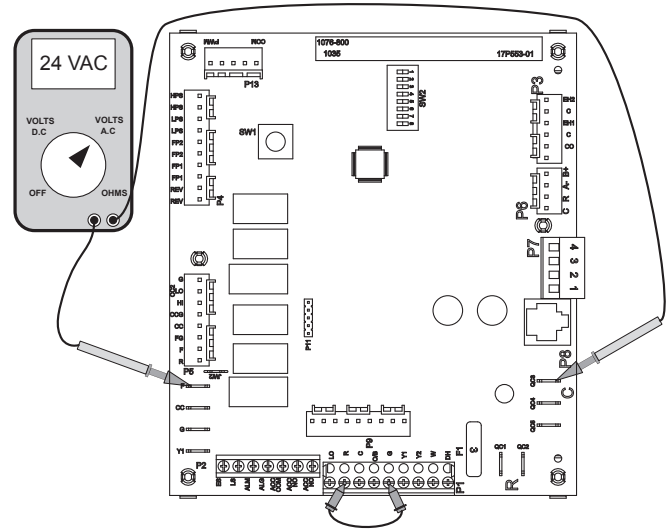

With the AID Tool go to the “Thermostat Inputs” Menu under “Diagnostics” and over-ride the “G” input to ON. If an AID Tool is not available remove the P1 connector to disconnect the thermostat from the board and place a jumper between “R” and “G” as shown. Put the board into test mode by holding SW1 for 2-5 seconds. The blower will come on and run in the “G” speed setting. To check the enable signal to the motor, measure 24VAC between the F and C terminals.

### To Check the Electric Heat Outputs

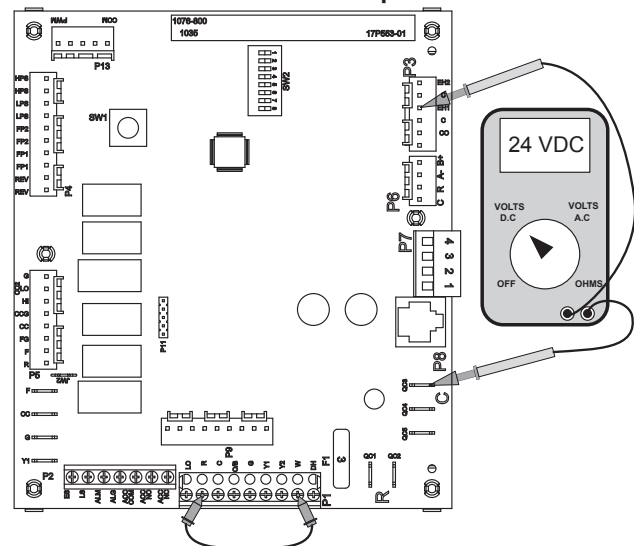

With the AID Tool go to the “Thermostat Inputs” Menu under “Diagnostics” and over-ride the “W” input to ON. If an AID Tool is not available remove the P1 connector to disconnect the thermostat from the board and place a jumper between “R” and “W” as shown. Put the board into test mode by holding SW1 for 2-5 seconds. The blower will come on and run in high speed. 10 seconds later electric heat output 1 (EH1) will be enabled followed by electric heat output 2 (EH2) in 7.5 seconds. Check EH1 by measuring DC volts between “C” and “EH1” and check EH2 by measuring DC volts between “C” and “EH2”.

# Jumping the Control Board

## Stage 1 Heating

With the AID Tool go to the “Thermostat Inputs” Menu under “Diagnostics” and over-ride the “Y1” input to ON. If an AID Tool is not available remove the P1 connector to disconnect the thermostat from the board. Place a jumper between the “R” and “Y1” terminals as shown.

The blower motor will start in “G” blower speed setting immediately the compressor will start 10 seconds later. If the unit is equipped with an ECM blower motor it will switch to low speed 15 seconds after the Y1 input.

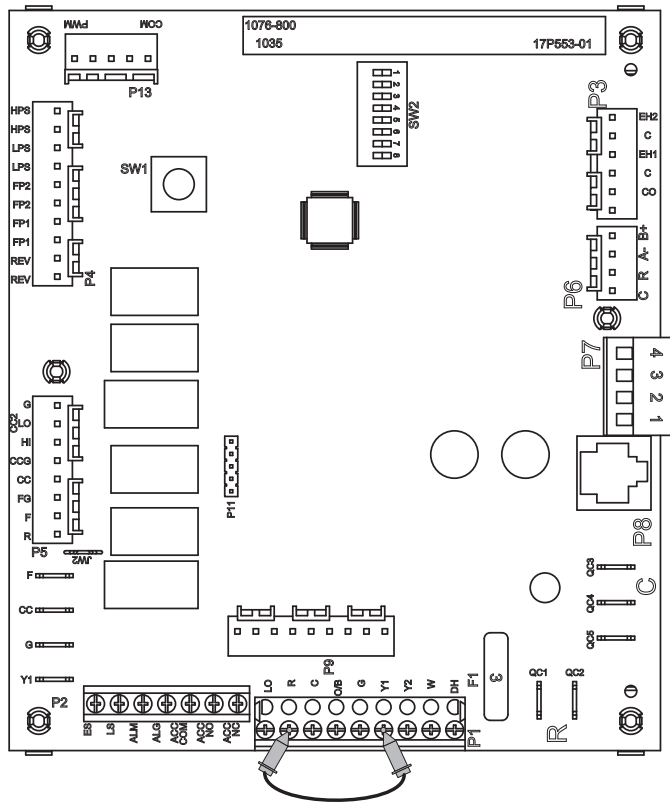

## Stage 2 Heating

With the AID Tool go to the “Thermostat Inputs” Menu under “Diagnostics” and over-ride the “Y1” and “Y2” inputs to ON. If an AID Tool is not available remove the P1 connector to disconnect the thermostat from the board. Place a jumper between the R, Y1, and Y2 terminals as shown.

The blower motor will start in “G” blower speed setting immediately the compressor will start 10 seconds later. If the unit is equipped with an ECM blower motor it will switch to low speed 15 seconds after the Y1 input. The compressor will stage to full capacity 20 seconds after the compressor starts, and the blower will change to high speed.

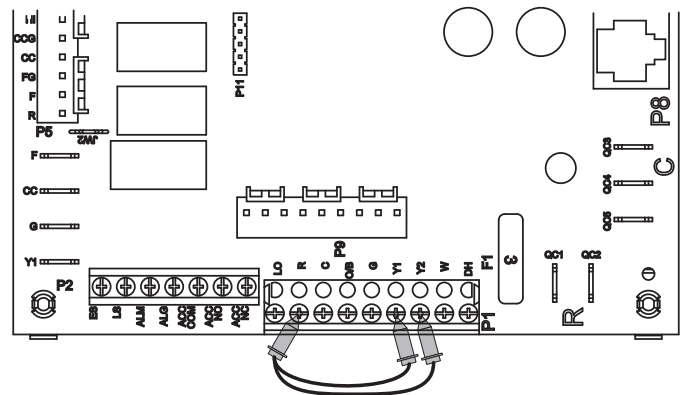

## Stage 3 Heating

With the AID Tool go to the “Thermostat Inputs” Menu under “Diagnostics” and over-ride the “Y1”, “Y2”, and “W” inputs to ON. If an AID Tool is not available remove the P1 connector to disconnect the thermostat from the board. Place a jumper between the R, Y1, Y2 and W terminals as shown.

The blower motor will start in “G” blower speed setting immediately the compressor will start 10 seconds later. If the unit is equipped with an ECM blower motor it will switch to low speed 15 seconds after the Y1 input. The compressor will stage to full capacity 20 seconds after the compressor starts, and the blower will change to high speed. The first stage of resistance heat is energized and with continuous third stage demand the second stage of resistance heat will engage in 5 minutes.

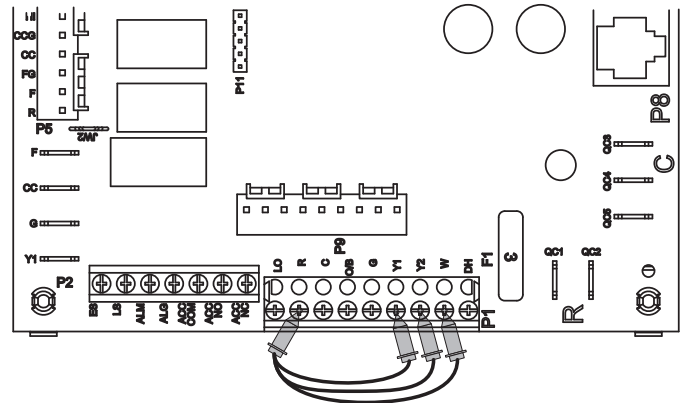

## Jumping the Control Board cont.

### Emergency Heat

With the AID Tool go to the “Thermostat Inputs” Menu under “Diagnostics” and over-ride the “W” input to ON. If an AID Tool is not available remove the P1 connector to disconnect the thermostat from the board. Place a jumper between the “R” and “W” terminals as shown.

The blower will start on high speed and after 20 seconds the first stage of resistance heat is energized. Continuing demand will engage the second stage after 2 minutes.

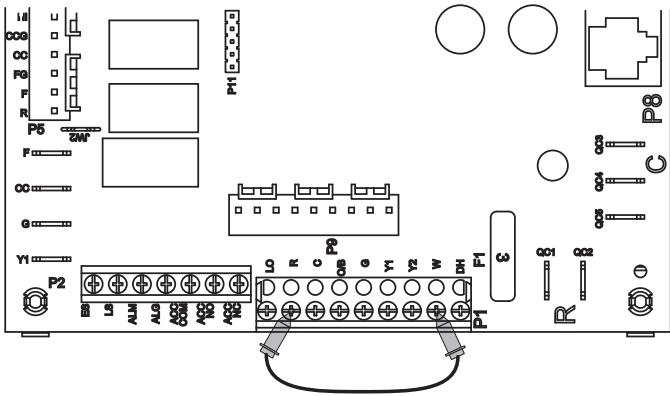

### Blower Only

With the AID Tool go to the “Thermostat Inputs” Menu under “Diagnostics” and over-ride the “G” input to ON. If an AID Tool is not available remove the P1 connector to disconnect the thermostat from the board. Place a jumper between the “R” and “G” terminals as shown.

The blower will start on the “G” speed setting. Also, regardless of blower speed setting, the blower will remain on for 30 seconds at the end of each heating, cooling, emergency heat, or reheat cycle.

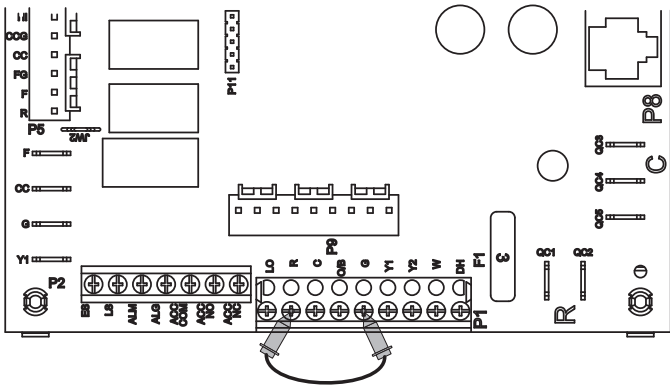

### Stage 1 Cooling

With the AID Tool go to the “Thermostat Inputs” Menu under “Diagnostics” and over-ride the “Y1” and “O” inputs to ON. If an AID Tool is not available remove the P1 connector to disconnect the thermostat from the board. Place a jumper between the R, O, and Y1 terminals as shown.

The blower motor will start in “G” blower speed setting immediately, the compressor will start 10 seconds later. If the unit is equipped with an ECM blower motor it will switch to low speed 15 seconds after the Y1 input.

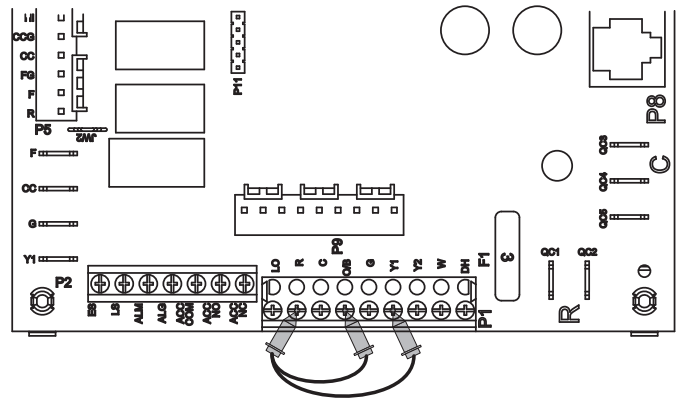

### Stage 2 Cooling

With the AID Tool go to the “Thermostat Inputs” Menu under “Diagnostics” and over-ride the “Y1”, “Y2”, and “O” inputs to ON. If an AID Tool is not available remove the P1 connector to disconnect the thermostat from the board. Place a jumper between the R, O, Y1, and Y2 terminals as shown.

The blower motor will start in “G” blower speed setting immediately the compressor will start 10 seconds later. If the unit is equipped with an ECM blower motor it will switch to low speed 15 seconds after the Y1 input. The compressor will stage to full capacity 20 seconds after the compressor starts, and the blower will change to high speed.

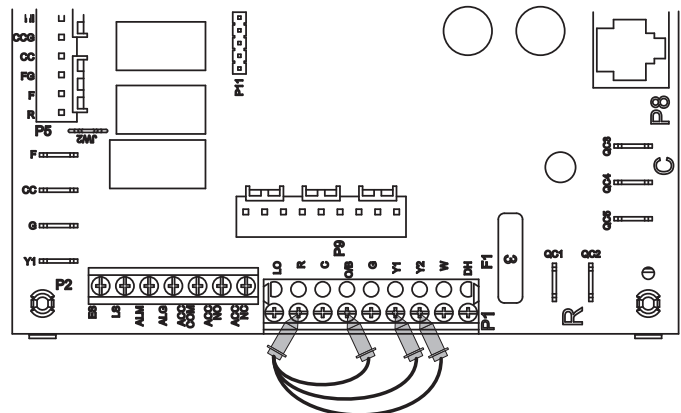

## Jumping the Control Board cont.

### Reheat Mode

With the AID Tool go to the “Thermostat Inputs” Menu under “Diagnostics” and over-ride the “DH” input to ON. If an AID Tool is not available remove the P1 connector to disconnect the thermostat from the board. Place a jumper between the R and DH terminals as shown.

The blower motor will start in “G” blower speed setting immediately the compressor will start 10 seconds later. If the unit is equipped with an ECM blower motor it will switch to low speed 15 seconds after the DH input. 20 seconds after the DH input is received the compressor will switch to full capacity and the blower motor will switch to dehumidification high speed. 30 seconds after the compressor starts the alarm/reheat output will energize.

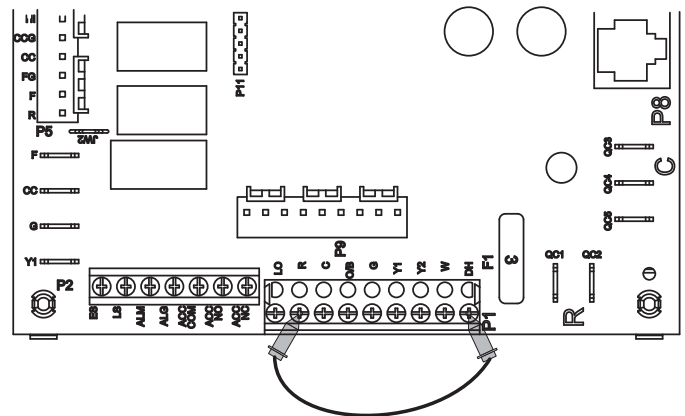

# Water Side Analysis: Heat of Extraction/Rejection

By determining the amount of heat extracted or rejected, the service technician can better judge the performance of the unit and verify whether or not the unit performance is acceptable. Use the following formula to find the heat of extraction/rejection.

### HEAT OF EXTRACTION/REJECTION

$$Q = \text{FLOW} \times \text{FLUID FACTOR} \times \text{TEMP DIFF}$$

$$\text{FLOW} = \text{gpm}$$

$$\text{TEMP DIFF} = \text{Water Rise or Drop in Fahrenheit degrees across the coax}$$

500 = FLUID FACTOR used for water

485 = FLUID FACTOR used for antifreeze solution

**Example:** Entering water temperature of 50°F, leaving water temperature 60.1°F, entering water pressure of 40 psi, leaving water pressure of 34.2 psi, entering air temperature of 70°F, and closed loop (485).

$$\Delta P = 40 \text{ psi} - 34.2 \text{ psi}$$

$$\Delta P = 5.8 \text{ psi}$$

Convert  $\Delta P$  to psi using pressure drop table in this manual.

A  $\Delta P$  of 5.8 psi equals 9 gpm.

$$Q = 9 \text{ gpm} \times 485 \times 10.1^\circ\text{F}$$

$$Q = 44,087 \text{ Btu/hr}$$

Next, find the Heat of Extraction/Rejection Data for the example unit. Match the entering water temperature at 9 gpm. Now, move to the right and read the number under "HR" and compare listed capacity data with actual performance. Note that the example calculation is within 4,800 Btu/hr of the listed HE. Remember to check the Correction Factors tables to adjust for entering air temperature and possibly antifreeze. The actual heat of extraction/rejection should be within 10% of catalog data. If the actual heat of extraction/rejection is less than 90% of catalog data, a further refrigeration check of the unit will be necessary to determine if the unit is charged properly, has a faulty component, or needs adjustment.

## Example Unit Data Tables

### Pressure Drop

Model	gpm	Pressure Drop (psi)				
		30°F	50°F	70°F	90°F	110°F
Example	5.0	1.4	1.1	0.9	0.7	0.5
	7.0	2.5	2.3	2.1	1.8	1.6
	9.0	6.0	5.8	5.5	5.3	5.1
	12.0	6.6	6.4	6.2	6.0	5.7

### Heat of Extraction/Rejection

Model	gpm	Heat of Extraction (HE)				Heat of Rejection (HR)				
		30°F	50°F	70°F	90°F	30°F	50°F	70°F	90°F	110°F
Example	5.0		24.6	33.0	41.7		47.4	45.3	44.1	
	7.0	19.0	25.7	34.3	42.4	41.5	47.7	45.8	44.2	42.4
	9.0	19.6	26.8	35.5	43.1	41.7	48.1	46.3	44.6	42.7

# Superheat/Subcooling

## Checking Superheat in the Heating Mode

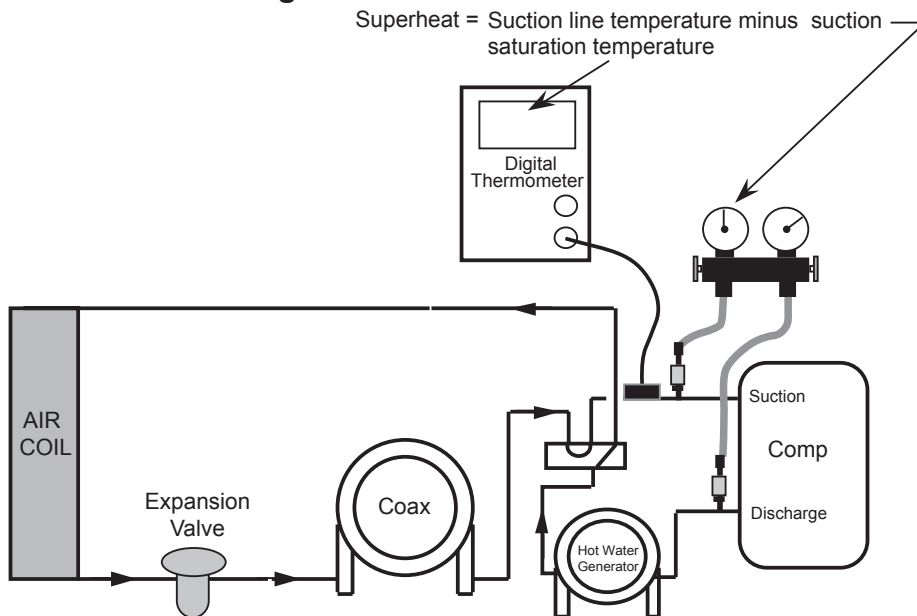

## Checking Superheat in the Cooling Mode

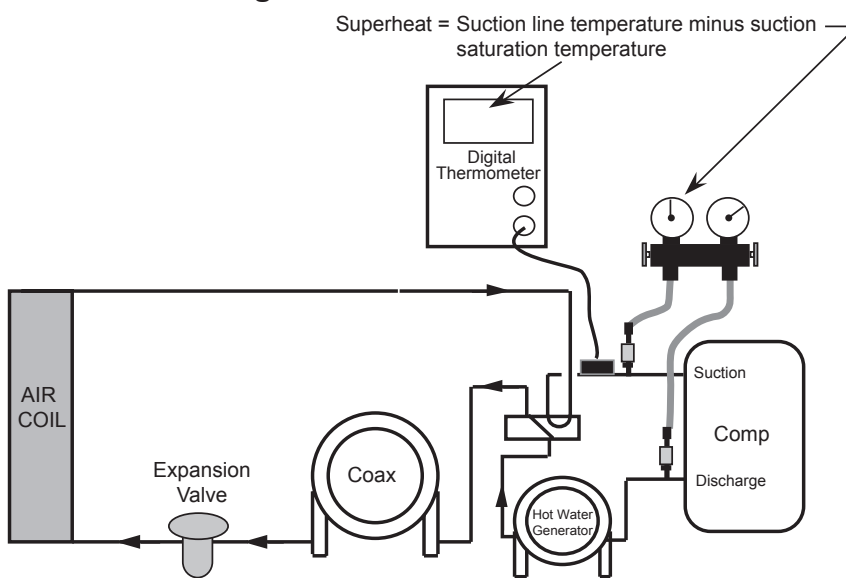

**NOTE:** Always turn hot water generator off during these tests.

1. Always check water and airflow before putting gages on the unit.
2. Determine superheat and compare with the values shown in the table.
3. If superheat is HIGH, there may be a restriction in the expansion device assembly or low charge. Also check entering air and water temperatures.
4. If superheat is HIGH and subcooling is LOW, the unit may be undercharged.

Entering Water Temperature	Heating		Cooling	
	Superheat	Subcooling	Superheat	Subcooling
030	9-14	5-9	25-35	15-25
050	10-14	5-9	10-18	15-25
070	12-16	5-8	9-14	13-18
090	N/A	N/A	8-13	13-18

Based on nominal 400 cfm per ton airflow and 80°F EAT cooling and 70°F EAT heating. Cooling air and water numbers can vary greatly with changes in humidity.

## Superheat/Subcooling cont.

### Checking Subcooling in the Heating Mode

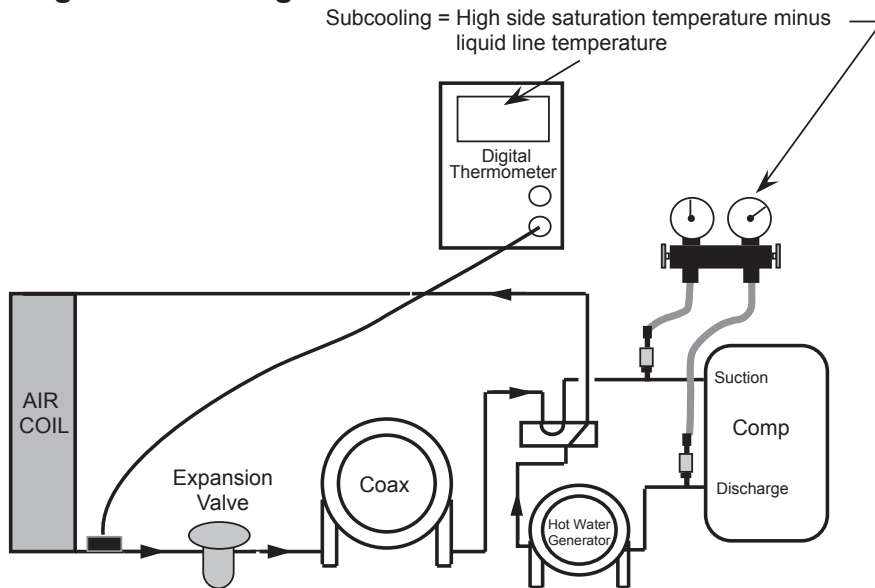

### Checking Subcooling in the Cooling Mode

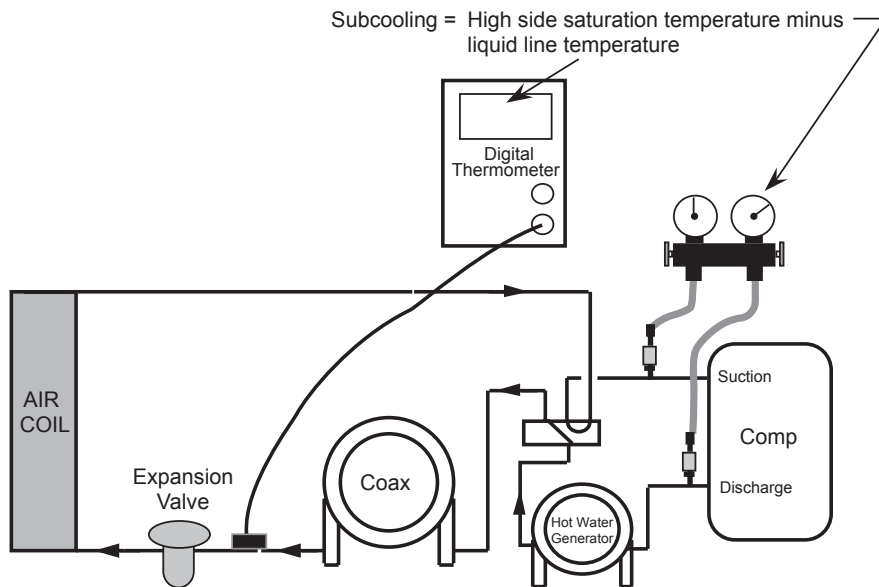

**NOTE:** Always turn hot water generator off during these tests.

1. Always check water and airflow before putting gages on the unit.
2. Determine subcooling and compare with the values shown in the table.
3. If superheat is HIGH, there may be a restriction in the TXV assembly, low charge, or the TXV bulb may have lost its charge. Also check entering air and water temperatures.
4. If superheat is HIGH and subcooling is LOW, the unit may be undercharged.

Entering Water Temperature	Heating		Cooling	
	Superheat	Subcooling	Superheat	Subcooling
030	9-14	5-9	25-35	15-25
050	10-14	5-9	10-18	15-25
070	12-16	5-8	9-14	13-18
090	N/A	N/A	8-13	13-18

Based on nominal 400 cfm per ton airflow and 80°F EAT cooling and 70°F EAT heating. Cooling air and water numbers can vary greatly with changes in humidity.

# Troubleshooting

## Single Speed/Dual Capacity Startup/Troubleshooting Form

### 1. Job Information

Model # \_\_\_\_\_ Job Name: \_\_\_\_\_ Loop: Open / Closed  
 Serial # \_\_\_\_\_ Install Date: \_\_\_\_\_ Hot Water Generator: Y / N

### 2. Flow Rate in gpm

	SOURCE COAX		LOAD COAX (Water-to-Water)	
	HEATING	COOLING	HEATING	COOLING
WATER IN Pressure:	a. _____ psi	a. _____ psi	a. _____ psi	a. _____ psi
WATER OUT Pressure:	b. _____ psi	b. _____ psi	b. _____ psi	b. _____ psi
Pressure Drop: a - b	c. _____ psi	c. _____ psi	c. _____ psi	c. _____ psi
Look up flow rate in table:	d. _____ gpm	d. _____ gpm	d. _____ gpm	d. _____ gpm

### 3. Temp. Rise/Drop Across Air Coil<sup>1</sup>

	HEATING	COOLING
SUPPLY AIR Temperature:	e. _____ °F	e. _____ °F
RETURN AIR Temperature:	f. _____ °F	f. _____ °F
Temperature Difference:	g. _____ °F	g. _____ °F

### 4. Temp. Rise/Drop Across Coaxial Heat Exchanger

	SOURCE COAX		LOAD COAX (Water-to-Water)	
	HEATING	COOLING	HEATING	COOLING
WATER IN Temperature:	h. _____ °F	h. _____ °F	h. _____ °F	h. _____ °F
WATER OUT Temperature:	i. _____ °F	i. _____ °F	i. _____ °F	i. _____ °F
Temperature Difference:	j. _____ °F	j. _____ °F	j. _____ °F	j. _____ °F

### 5. Heat of Rejection (HR)/Heat of Extraction (HE)

Brine Factor<sup>2</sup>: k. \_\_\_\_\_

HR/HE = d x g x k

	HEATING	COOLING
l. _____ Btu/h	l. _____ Btu/h	l. _____ Btu/h

### STEPS 6-9 NEED ONLY BE COMPLETED IF A PROBLEM IS SUSPECTED.

### 6. Watts

	ENERGY MONITOR	
	HEATING	COOLING
Volts:	m. _____ Volts	m. _____ Volts
Total Amps (Comp. + Blower) <sup>3</sup> :	n. _____ Amps	n. _____ Amps
Watts = m x n x 0.85:	o. _____ Watts	o. _____ Watts

### 7. Capacity

	HEATING	COOLING
Cooling Capacity = l - (o x 3.413):	p. _____ Btu/h	p. _____ Btu/h
Heating Capacity = l + (o x 3.413):		

### 8. Efficiency

	HEATING	COOLING
Cooling EER = p / o:	q. _____ Btu/h	q. _____ Btu/h
Heating COP = p / (o x 3.413):		

### 9. Superheat (S.H.)/Subcooling (S.C.)

	HEATING	COOLING
Suction Pressure:	r. _____ psi	r. _____ psi
Suction Saturation Temperature:	s. _____ °F	s. _____ °F
Suction Line Temperature:	t. _____ °F	t. _____ °F
S.H. = t - s	u. _____ °F	u. _____ °F
Head Pressure:	v. _____ psi	v. _____ psi
High Pressure Saturation Temp:	w. _____ °F	w. _____ °F
Liquid Line Temperature <sup>4</sup> :	x. _____ °F	x. _____ °F
S.C. = w - x	y. _____ °F	y. _____ °F

Software Version
ABC: _____
I22: _____
T'STAT: _____

**NOTES:** <sup>1</sup> Steps 3-9 should be conducted with the hot water generator disconnected.

<sup>2</sup> Use 500 for pure water, 485 for methanol or Enviranol™. (This constant is derived by multiplying the weight of one gallon of water (8.34) times the minutes in one hour (60) times the specific heat of the fluid. Water has a specific heat of 1.0.

<sup>3</sup> If there is only one source of power for the compressor and blower, amp draw can be measured at the source wiring connection.

<sup>4</sup> Liquid line is between the coax and the expansion device in the cooling mode; between the air coil and the expansion device in the heating mode.

# Troubleshooting cont.

## Startup/Troubleshooting Form

Dealer: \_\_\_\_\_ Controls Info: \_\_\_\_\_  
 Phone #: \_\_\_\_\_ Date: \_\_\_\_\_ ABC Version: \_\_\_\_\_  
 Problem: \_\_\_\_\_ IZ2 24V Version: \_\_\_\_\_  
 Model #: \_\_\_\_\_ T-Stat Version: \_\_\_\_\_  
 Serial #: \_\_\_\_\_ Installed Sensors: \_\_\_\_\_

## COOLING CYCLE ANALYSIS

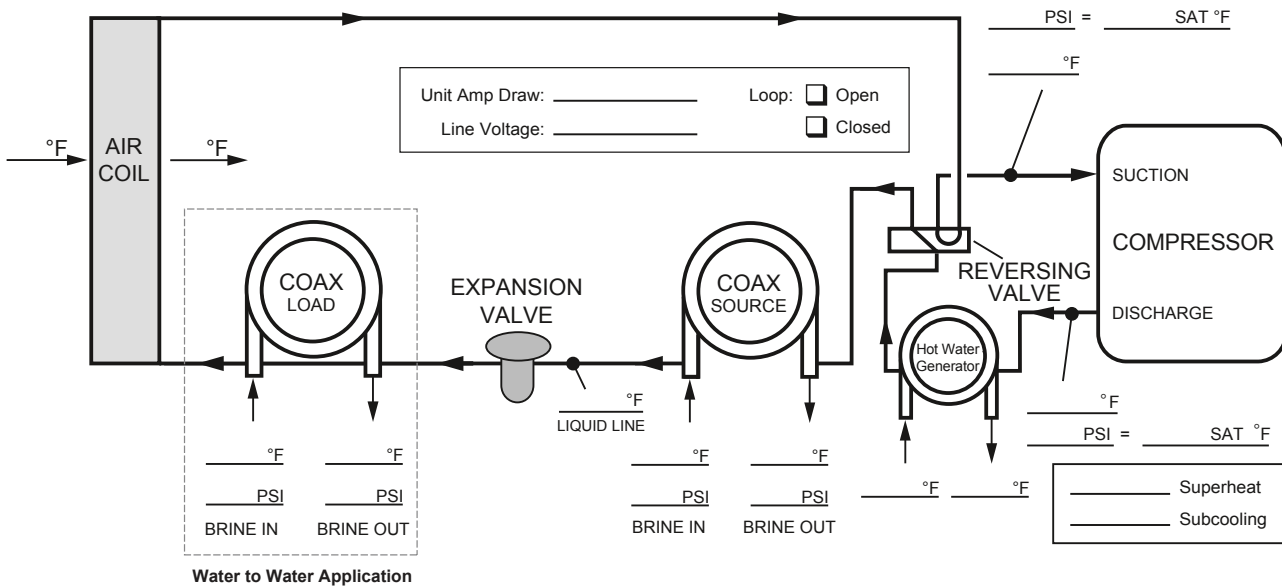

**Heat of Extraction/Rejection = gpm x 500 (485 for water/antifreeze) x ΔT**

**Note: DO NOT** hook up pressure gauges unless there appears to be a performance problem.

## HEATING CYCLE ANALYSIS

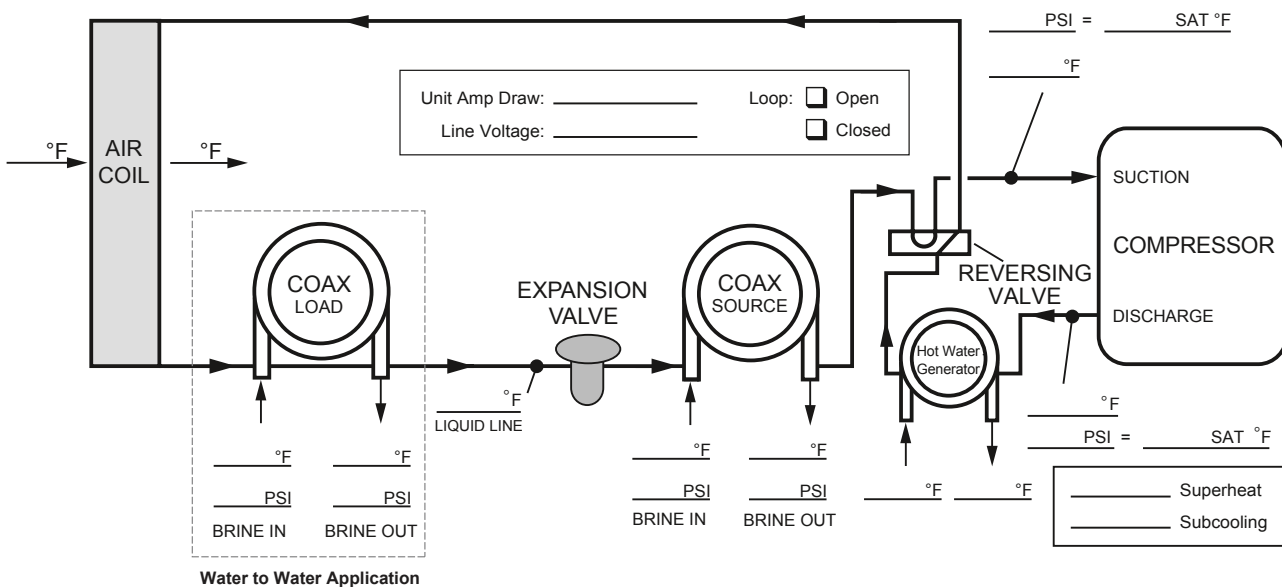

# Performance Data

## 024 - Dual Capacity with 5-Speed ECM High Speed (800 cfm)

EWT °F	Flow gpm	WPD		HEATING - EAT 70°F							COOLING - EAT 80/67 °F							
		PSI	FT	Airflow cfm	HC kBtuh	Power kW	HE kBtuh	LAT °F	COP	HWC kBtuh	Airflow cfm	TC kBtuh	SC kBtuh	S/T Ratio	Power kW	HR kBtuh	EER	HWC kBtuh
20	4.0	2.0	4.6	Operation not recommended							Operation not recommended							
	6.0	5.5	12.7	Operation not recommended							Operation not recommended							
	8.0	9.0	20.8	600 800	15.7 16.3	1.43 1.45	10.8 11.4	94.2 88.9	3.22 3.29	2.1 2.0	600 800	24.5 24.9	15.6 17.0	0.64 0.68	0.99 1.04	27.9 28.4	24.7 23.8	- -
30	4.0	1.9	4.5	Operation not recommended							Operation not recommended							
	6.0	5.3	12.3	600 800	18.3 18.9	1.51 1.56	13.2 13.5	98.3 91.8	3.56 3.55	2.3 2.1	600 800	24.5 24.9	15.6 17.0	0.64 0.68	0.99 1.04	27.9 28.4	24.7 23.8	- -
	8.0	8.7	20.2	600 800	18.6 19.2	1.52 1.57	13.4 13.9	98.8 92.3	3.58 3.59	2.3 2.2	600 800	24.6 25.2	15.6 17.0	0.63 0.67	0.96 1.01	27.9 28.6	25.6 25.0	- -
40	4.0	1.9	4.3	Operation not recommended							Operation not recommended							
	6.0	5.2	12.0	600 800	20.1 20.8	1.53 1.57	14.9 15.4	101.1 94.0	3.85 3.89	2.5 2.3	600 800	24.6 25.0	16.6 18.2	0.68 0.73	1.07 1.13	28.2 28.9	22.9 22.2	- -
	8.0	8.5	19.6	600 800	20.5 21.2	1.55 1.58	15.3 15.8	101.7 94.5	3.89 3.93	2.6 2.4	600 800	24.7 25.3	16.6 18.2	0.67 0.72	1.04 1.09	28.3 29.0	23.7 23.2	- -
50	4.0	1.8	4.2	600 800	21.1 21.8	1.53 1.55	15.9 16.5	102.6 95.2	4.05 4.11	2.7 2.5	600 800	23.9 25.1	16.1 17.9	0.67 0.71	1.21 1.28	28.0 29.5	19.7 19.7	1.1 1.2
	6.0	5.0	11.6	600 800	21.9 22.6	1.56 1.59	16.6 17.2	103.8 96.2	4.10 4.18	2.8 2.6	600 800	24.4 25.6	16.3 18.1	0.67 0.71	1.14 1.20	28.3 29.7	21.3 21.4	1.0 1.2
	8.0	8.2	19.0	600 800	22.4 23.1	1.58 1.60	17.0 17.6	104.6 96.7	4.16 4.23	2.9 2.6	600 800	24.6 25.9	17.4 19.3	0.71 0.75	1.11 1.17	28.4 29.9	22.1 22.1	1.0 1.1
60	4.0	1.8	4.1	600 800	24.0 24.7	1.61 1.63	18.5 19.2	107.0 98.6	4.35 4.46	3.0 2.8	600 800	23.8 25.0	16.1 17.9	0.67 0.72	1.33 1.39	28.4 29.7	18.0 18.0	1.3 1.4
	6.0	4.9	11.2	600 800	25.0 25.9	1.66 1.67	19.4 20.2	108.7 99.9	4.42 4.54	3.0 2.8	600 800	24.4 25.6	16.3 18.0	0.67 0.71	1.26 1.31	28.7 30.0	19.4 19.5	1.2 1.4
	8.0	8.0	18.4	600 800	25.7 26.5	1.68 1.69	19.9 20.8	109.6 100.7	4.48 4.61	3.2 2.9	600 800	24.6 25.9	17.1 19.0	0.70 0.74	1.23 1.29	28.8 30.2	20.0 20.1	1.1 1.3
70	4.0	1.7	3.9	600 800	26.8 29.7	1.70 1.73	21.0 23.8	111.4 104.4	4.62 5.03	3.2 3.0	600 800	23.8 25.5	16.0 18.5	0.67 0.73	1.37 1.43	28.5 30.4	18.5 17.8	1.6 1.7
	6.0	4.7	10.9	600 800	28.2 29.1	1.76 1.76	22.2 23.1	113.5 103.7	4.71 4.86	3.4 3.1	600 800	24.4 25.5	16.2 18.0	0.66 0.71	1.38 1.43	29.1 30.4	17.7 17.9	1.5 1.7
	8.0	7.7	17.8	600 800	28.9 29.9	1.78 1.77	22.9 23.9	114.6 104.6	4.77 4.95	3.5 3.2	600 800	24.7 25.8	16.9 18.7	0.68 0.72	1.35 1.40	29.3 30.6	18.4 18.4	1.4 1.6
80	4.0	1.6	3.8	600 800	28.8 29.8	1.74 1.73	22.8 23.9	114.4 104.5	4.84 5.05	3.6 3.3	600 800	22.8 23.8	15.8 17.6	0.69 0.74	1.60 1.65	28.3 29.4	14.3 14.4	2.0 2.1
	6.0	4.5	10.5	600 800	30.4 31.5	1.81 1.80	24.3 25.4	117.0 106.4	4.92 5.14	3.7 3.5	600 800	23.5 24.4	16.0 17.8	0.68 0.73	1.55 1.59	28.7 29.8	15.2 15.3	1.9 2.1
	8.0	7.4	17.2	600 800	31.3 32.4	1.84 1.81	25.1 26.2	118.3 107.5	5.00 5.25	3.9 3.6	600 800	23.7 24.7	16.4 18.2	0.69 0.74	1.51 1.56	28.9 30.0	15.7 15.8	1.8 2.0
90	4.0	1.6	3.7	600 800	30.8 31.9	1.79 1.76	24.7 25.9	117.5 106.9	5.04 5.30	3.9 3.7	600 800	21.9 22.6	15.6 17.4	0.72 0.77	1.76 1.81	27.9 28.8	12.4 12.5	2.5 2.7
	6.0	4.4	10.1	600 800	32.7 33.9	1.87 1.84	26.3 27.6	120.5 109.2	5.13 5.40	4.1 3.8	600 800	22.5 23.3	15.8 17.6	0.70 0.75	1.71 1.76	28.3 29.3	13.1 13.3	2.4 2.6
	8.0	7.2	16.6	600 800	33.7 34.9	1.90 1.85	27.3 28.6	122.1 110.4	5.21 5.53	4.3 4.0	600 800	22.0 23.6	15.3 17.7	0.70 0.75	1.62 1.72	27.5 29.5	13.6 13.7	2.2 2.5
100	4.0	1.5	3.5	Operation not recommended							Operation not recommended							
	6.0	4.2	9.8	Operation not recommended							Operation not recommended							
	8.0	6.9	16.0	600 800	20.9 21.6	15.0 16.6	0.72 0.77	1.94 1.97	27.6 28.4	10.8 11.0	2.9 3.2	600 800	21.2 21.9	15.0 16.6	0.71 0.76	1.91 1.94	27.7 28.5	11.1 11.3
110	4.0	1.5	3.4	Operation not recommended							Operation not recommended							
	6.0	4.1	9.4	Operation not recommended							Operation not recommended							
	8.0	6.7	15.4	600 800	19.4 19.9	14.1 15.7	0.73 0.79	2.18 2.19	26.8 27.4	8.9 9.1	3.7 4.0	600 800	19.6 20.1	14.0 15.4	0.71 0.77	2.14 2.16	26.9 27.5	9.2 9.3
120	4.0	1.4	3.3	Operation not recommended							Operation not recommended							
	6.0	3.9	9.0	Operation not recommended							Operation not recommended							
	8.0	6.4	14.8	600 800	18.3 18.7	14.7 16.0	0.80 0.86	2.41 2.48	26.6 27.1	7.6 7.5	4.3 4.7	600 800	18.5 18.9	14.7 16.0	0.80 0.85	2.34 2.41	26.5 27.1	7.9 7.8

Performance capacities shown in thousands of Btuh.

# Performance Data

## 024 - Dual Capacity with 5-Speed ECM Low Speed (600 cfm)

EWT °F	Flow gpm	WPD		HEATING - EAT 70°F							COOLING - EAT 80/67 °F							
		PSI	FT	Airflow cfm	HC kBtuh	Power kW	HE kBtuh	LAT °F	COP	HWC kBtuh	Airflow cfm	TC kBtuh	SC kBtuh	S/T Ratio	Power kW	HR kBtuh	EER	HWC kBtuh
20	3.0	1.1	2.4	Operation not recommended							Operation not recommended							
	5.0	4.0	9.2	Operation not recommended							Operation not recommended							
	7.0	6.7	15.4	500 600	11.3 11.5	1.11 1.10	7.5 7.7	91.0 87.7	2.99 3.06	1.8 1.7	Operation not recommended							
30	3.0	1.0	2.4	Operation not recommended							Operation not recommended							
	5.0	3.9	8.9	500 600	12.9 13.2	1.12 1.16	9.0 9.3	93.8 90.4	3.35 3.35	1.7 1.6	500 600	17.0 17.3	11.9 13.0	0.70 0.75	0.63 0.66	19.1 19.5	27.0 26.1	- -
	7.0	6.5	15.0	500 600	13.3 13.5	1.18 1.17	9.3 9.5	94.6 90.8	3.30 3.38	1.8 1.7	500 600	17.1 17.5	11.9 13.0	0.70 0.74	0.61 0.64	19.2 19.7	28.0 27.3	- -
40	3.0	1.0	2.3	Operation not recommended							Operation not recommended							
	5.0	3.7	8.7	500 600	14.6 15.0	1.13 1.15	10.7 11.1	97.0 93.2	3.78 3.82	1.7 1.6	500 600	17.7 18.0	12.3 13.4	0.69 0.74	0.70 0.73	20.1 20.5	25.2 24.5	- -
	7.0	6.3	14.5	500 600	14.9 15.4	1.14 1.17	11.0 11.4	97.5 93.7	3.82 3.86	1.8 1.7	500 600	17.8 18.2	12.3 13.4	0.69 0.74	0.68 0.71	20.1 20.6	26.2 25.6	- -
50	3.0	1.0	2.2	500 600	15.7 16.2	1.11 1.12	12.0 12.4	99.1 95.0	4.16 4.22	1.8 1.7	500 600	17.0 17.9	11.5 12.8	0.68 0.71	0.81 0.85	19.8 20.8	21.1 21.1	5.0 0.6
	5.0	3.6	8.4	500 600	16.3 16.8	1.13 1.15	12.4 12.9	100.2 96.0	4.21 4.29	1.8 1.8	500 600	17.4 18.3	11.6 12.9	0.67 0.71	0.76 0.80	20.0 21.0	22.9 22.9	0.5 0.6
	7.0	6.1	14.1	500 600	16.7 17.2	1.14 1.16	12.8 13.2	100.9 96.5	4.27 4.35	2.0 1.8	500 600	17.6 18.5	12.4 13.8	0.71 0.75	0.74 0.78	20.1 21.2	23.7 23.7	0.5 0.5
60	3.0	0.9	2.2	500 600	17.7 18.3	1.14 1.15	13.8 14.4	102.8 98.2	4.56 4.67	2.0 1.8	500 600	16.4 17.2	11.4 12.7	0.70 0.74	0.89 0.93	19.4 20.3	18.3 18.4	0.7 0.8
	5.0	3.5	8.1	500 600	18.5 19.1	1.17 1.18	14.5 15.1	104.3 99.5	4.63 4.75	2.0 1.9	500 600	16.8 17.5	11.5 12.8	0.69 0.73	0.85 0.88	19.6 20.6	19.7 19.9	0.7 0.8
	7.0	5.9	13.6	500 600	19.0 19.6	1.19 1.19	14.9 15.5	105.1 100.2	4.69 4.83	2.1 1.9	500 600	16.9 17.8	12.2 13.5	0.72 0.76	0.83 0.87	19.7 20.7	20.4 20.5	0.6 0.7
70	3.0	0.9	2.1	500 600	19.7 20.9	1.17 1.19	15.7 16.8	106.5 102.3	4.94 5.15	2.2 2.0	500 600	15.7 16.8	11.3 13.1	0.72 0.78	0.98 0.96	19.0 20.1	16.1 17.5	1.0 1.1
	5.0	3.4	7.9	500 600	20.7 21.4	1.21 1.21	16.6 17.3	108.4 103.1	5.02 5.19	2.2 2.0	500 600	16.1 16.8	11.5 12.7	0.71 0.76	0.94 0.97	19.3 20.1	17.2 17.3	0.9 1.0
	7.0	5.7	13.2	500 600	19.0 22.0	1.16 1.22	15.0 17.8	105.2 104.0	4.80 5.29	2.3 2.1	500 600	16.3 17.0	11.9 13.2	0.73 0.78	0.91 0.95	19.4 20.2	17.8 17.9	0.9 1.0
80	3.0	0.9	2.0	500 600	20.9 21.7	1.20 1.19	16.8 17.6	108.8 103.4	5.13 5.35	2.4 2.2	500 600	15.0 15.6	11.3 12.5	0.75 0.80	1.09 1.12	18.7 19.5	13.8 13.9	1.4 1.5
	5.0	3.3	7.6	500 600	22.1 22.9	1.24 1.23	17.9 18.7	111.0 105.3	5.22 5.45	2.4 2.3	500 600	15.4 16.1	11.4 12.6	0.74 0.79	1.05 1.08	19.0 19.8	14.7 14.9	1.3 1.4
	7.0	5.5	12.7	500 600	22.8 23.6	1.26 1.24	18.5 19.3	112.2 106.3	5.30 5.57	2.6 2.4	500 600	15.6 16.3	11.7 13.0	0.75 0.80	1.03 1.06	19.1 19.9	15.2 15.3	1.2 1.3
90	3.0	0.8	1.9	500 600	22.1 22.9	1.22 1.20	18.0 18.8	111.0 105.4	5.32 5.60	2.8 2.5	500 600	14.4 14.9	11.2 12.5	0.78 0.84	1.20 1.23	18.4 19.1	12.0 12.1	1.9 2.0
	5.0	3.2	7.3	500 600	23.5 24.4	1.27 1.25	19.2 20.1	113.6 107.6	5.41 5.71	2.9 2.6	500 600	14.8 15.3	11.4 12.6	0.77 0.82	1.17 1.19	18.8 19.4	12.7 12.8	1.8 1.9
	7.0	5.3	12.3	500 600	24.3 25.1	1.29 1.26	19.9 20.8	114.9 108.7	5.50 5.84	2.9 2.6	500 600	15.6 15.5	11.0 12.7	0.71 0.82	1.18 1.17	19.6 19.5	13.2 13.2	1.7 1.9
100	3.0	0.8	1.9	Operation not recommended							Operation not recommended							
	5.0	3.1	7.1	Operation not recommended							Operation not recommended							
	7.0	5.1	11.8	Operation not recommended							Operation not recommended							
110	3.0	0.8	1.8	Operation not recommended							Operation not recommended							
	5.0	2.9	6.8	Operation not recommended							Operation not recommended							
	7.0	4.9	11.4	Operation not recommended							Operation not recommended							
120	3.0	0.7	1.7	Operation not recommended							Operation not recommended							
	5.0	2.8	6.5	Operation not recommended							Operation not recommended							
	7.0	4.7	10.9	Operation not recommended							Operation not recommended							

Performance capacities shown in thousands of Btuh.

# Performance Data

## 036 - Dual Capacity with 5-Speed ECM High Speed (1200 cfm)

EWT °F	Flow gpm	WPD		HEATING - EAT 70°F							COOLING - EAT 80/67 °F							
		PSI	FT	Airflow cfm	HC kBtuh	Power kW	HE kBtuh	LAT °F	COP	HWC kBtuh	Airflow cfm	TC kBtuh	SC kBtuh	S/T Ratio	Power kW	HR kBtuh	EER	HWC kBtuh
20	5.0	2.3	5.4	Operation not recommended							Operation not recommended							
	7.0	4.6	10.5	Operation not recommended							Operation not recommended							
	9.0	6.8	15.7	1000 1200	25.5 25.4	2.08 2.22	18.4 17.8	93.6 89.6	3.59 3.35	3.3 3.0								
30	5.0	2.3	5.3	Operation not recommended							Operation not recommended							
	7.0	4.4	10.2	1000 1200	27.3 28.1	2.28 2.35	19.6 20.1	95.3 91.7	3.52 3.51	3.5 3.2	1000 1200	32.5 33.1	22.4 24.5	0.69 0.74	1.38 1.46	37.3 38.0	23.5 22.7	- -
	9.0	6.6	15.2	1000 1200	28.8 28.7	2.22 2.37	21.2 20.6	96.7 92.1	3.80 3.55	3.6 3.3	1000 1200	32.7 33.5	22.4 24.5	0.69 0.73	1.34 1.41	37.3 38.3	24.4 23.8	- -
40	5.0	2.2	5.1	Operation not recommended							Operation not recommended							
	7.0	4.3	9.9	1000 1200	31.1 32.1	2.34 2.39	23.1 23.9	98.8 94.7	3.90 3.94	3.8 3.5	1000 1200	34.8 35.4	22.8 24.9	0.65 0.70	1.55 1.62	40.1 41.0	22.5 21.8	- -
	9.0	6.4	14.8	1000 1200	31.7 32.8	2.36 2.41	23.7 24.5	99.4 95.3	3.94 3.98	3.9 3.6	1000 1200	35.1 35.9	22.8 24.9	0.65 0.69	1.50 1.57	40.2 41.2	23.4 22.8	- -
50	5.0	2.1	4.9	1000 1200	33.7 34.7	2.34 2.37	25.7 26.6	101.2 96.8	4.21 4.28	4.1 3.8	1000 1200	35.2 37.0	21.0 23.4	0.60 0.63	1.79 1.89	41.3 43.5	19.6 19.6	1.8 1.9
	7.0	4.2	9.6	1000 1200	34.9 36.0	2.40 2.43	26.7 27.7	102.3 97.8	4.27 4.35	4.2 3.9	1000 1200	35.9 37.8	21.3 23.6	0.59 0.62	1.69 1.77	41.7 43.8	21.3 21.3	1.7 1.8
	9.0	6.2	14.3	1000 1200	35.7 36.8	2.42 2.45	27.4 28.4	103.0 98.4	4.33 4.40	4.4 4.0	1000 1200	36.3 38.2	22.7 25.2	0.63 0.66	1.65 1.73	41.9 44.1	22.0 22.1	1.6 1.7
60	5.0	2.1	4.8	1000 1200	36.8 38.0	2.45 2.46	28.5 29.6	104.1 99.3	4.41 4.52	4.6 4.2	1000 1200	35.0 36.7	22.1 24.6	0.63 0.67	2.03 2.12	42.0 44.0	17.2 17.3	2.1 2.3
	7.0	4.0	9.3	1000 1200	38.5 39.7	2.52 2.53	29.9 31.1	105.6 100.6	4.48 4.59	4.7 4.4	1000 1200	35.9 37.6	22.4 24.9	0.62 0.66	1.93 2.01	42.5 44.4	18.6 18.7	2.0 2.2
	9.0	6.0	13.9	1000 1200	39.4 40.7	2.54 2.56	30.7 32.0	106.5 101.4	4.54 4.67	4.9 4.5	1000 1200	36.2 38.0	23.6 26.2	0.65 0.69	1.89 1.97	42.6 44.7	19.2 19.3	1.9 2.1
70	5.0	2.0	4.6	1000 1200	40.0 42.1	2.55 2.61	31.3 33.2	107.0 102.5	4.59 4.73	5.1 4.7	1000 1200	34.9 37.1	23.3 27.1	0.67 2.12	2.28 2.07	42.7 44.2	18.5 17.9	2.6 2.8
	7.0	3.9	9.0	1000 1200	42.1 43.4	2.64 2.64	33.0 34.4	108.9 103.5	4.67 4.82	5.3 4.9	1000 1200	35.8 37.3	23.6 26.2	0.66 0.70	2.18 2.25	43.2 45.0	16.4 16.6	2.4 2.7
	9.0	5.8	13.4	1000 1200	43.1 44.6	2.67 2.66	34.0 35.5	109.9 104.4	4.73 4.91	5.4 5.0	1000 1200	36.2 37.8	24.6 27.2	0.68 0.72	2.12 2.21	43.4 45.3	17.0 17.1	2.3 2.5
80	5.0	1.9	4.5	1000 1200	42.8 44.3	2.62 2.60	33.9 35.5	109.7 104.2	4.79 4.99	5.8 5.4	1000 1200	33.8 35.1	23.2 25.8	0.69 0.73	2.43 2.51	42.1 43.7	13.9 14.0	3.2 3.4
	7.0	3.8	8.7	1000 1200	45.3 46.8	2.73 2.70	36.0 37.6	111.9 106.1	4.87 5.09	6.0 5.6	1000 1200	34.7 36.1	23.5 26.0	0.68 0.72	2.35 2.42	42.7 44.3	14.8 14.9	3.0 3.3
	9.0	5.6	12.9	1000 1200	46.6 48.2	2.76 2.72	37.2 38.9	113.2 107.2	4.95 5.19	6.2 5.7	1000 1200	35.1 36.5	24.1 26.7	0.69 0.73	2.30 2.37	42.9 44.6	15.2 15.4	2.8 3.1
90	5.0	1.9	4.3	1000 1200	45.7 47.3	2.69 2.65	36.5 38.3	112.3 106.5	4.98 5.23	6.6 6.1	1000 1200	32.6 33.8	23.1 25.6	0.71 0.76	2.59 2.66	41.5 42.8	12.6 12.7	4.1 4.3
	7.0	3.6	8.4	1000 1200	48.5 50.3	2.81 2.76	39.0 40.9	114.9 108.8	5.06 5.34	6.8 6.3	1000 1200	33.6 34.8	23.4 25.9	0.70 0.74	2.52 2.58	42.2 43.6	13.3 13.5	3.8 4.1
	9.0	5.4	12.5	1000 1200	50.1 51.8	2.85 2.78	40.3 42.3	116.4 110.0	5.15 5.46	7.0 6.5	1000 1200	35.8 35.2	26.4 26.1	0.74 0.74	2.38 2.53	43.9 43.8	15.0 13.9	3.5 3.9
100	5.0	1.8	4.2	Operation not recommended							Operation not recommended							
	7.0	3.5	8.1	1000 1200	32.6 33.7	24.2 26.9	0.74 0.80	2.77 2.81	42.1 43.3	11.8 12.0	4.6 5.0							
	9.0	5.2	12.0	1000 1200	33.0 34.1	24.1 26.7	0.73 0.78	2.72 2.76	42.3 43.5	12.1 12.3	4.3 4.7							
110	5.0	1.7	4.0	Operation not recommended							Operation not recommended							
	7.0	3.4	7.8	1000 1200	31.7 32.6	25.1 27.9	0.79 0.86	3.01 3.03	42.0 42.9	10.5 10.7	5.8 6.2							
	9.0	5.0	11.6	1000 1200	32.0 32.9	24.7 27.3	0.77 0.83	2.96 2.99	42.1 43.1	10.8 11.0	5.4 5.9							
120	5.0	1.7	3.8	Operation not recommended							Operation not recommended							
	7.0	3.2	7.5	1000 1200	28.9 29.4	22.7 24.6	0.78 0.84	3.49 3.58	40.8 41.7	8.3 8.2	6.9 7.4							
	9.0	4.8	11.1	1000 1200	29.2 29.8	22.7 24.6	0.78 0.83	3.37 3.48	40.7 41.7	8.6 8.6	6.4 7.1							

Performance capacities shown in thousands of Btuh.

# Performance Data

## 036 - Dual Capacity with 5-Speed ECM Low Speed (1000 cfm)

EWT °F	Flow gpm	WPD		HEATING - EAT 70°F							COOLING - EAT 80/67 °F							
		PSI	FT	Airflow cfm	HC kBtuh	Power kW	HE kBtuh	LAT °F	COP	HWC kBtuh	Airflow cfm	TC kBtuh	SC kBtuh	S/T Ratio	Power kW	HR kBtuh	EER	HWC kBtuh
20	4.0	1.5	3.5	Operation not recommended							Operation not recommended							
	6.0	3.4	7.8	Operation not recommended							Operation not recommended							
	8.0	5.4	12.4	850 1000	17.4 17.5	1.55 1.65	12.1 11.9	89.0 86.2	3.30 3.11	2.9 2.6	Operation not recommended							
30	4.0	1.5	3.4	Operation not recommended							Operation not recommended							
	6.0	3.3	7.6	850 1000	19.5 20.1	1.71 1.76	13.7 14.1	91.3 88.6	3.35 3.34	2.8 2.5	850 1000	25.4 25.9	18.1 19.8	0.71 0.77	0.93 0.98	28.6 29.2	27.3 26.3	- -
	8.0	5.2	12.1	850 1000	20.4 20.5	1.67 1.78	14.7 14.4	92.2 89.0	3.58 3.38	2.9 2.6	850 1000	25.6 26.2	18.1 19.8	0.71 0.76	0.90 0.95	28.7 29.4	28.3 27.6	- -
40	4.0	1.4	3.3	Operation not recommended							Operation not recommended							
	6.0	3.2	7.4	850 1000	22.5 23.2	1.74 1.78	16.5 17.1	94.5 91.4	3.78 3.82	2.8 2.6	850 1000	26.6 27.1	18.9 20.6	0.71 0.76	1.00 1.05	30.1 30.7	26.6 25.9	- -
	8.0	5.1	11.7	850 1000	22.9 23.7	1.76 1.80	16.9 17.5	95.0 91.9	3.82 3.86	2.9 2.7	850 1000	26.8 27.5	18.9 20.6	0.70 0.75	0.97 1.02	30.2 30.9	27.7 27.0	- -
50	4.0	1.4	3.2	850 1000	24.5 25.3	1.73 1.75	18.6 19.3	96.7 93.4	4.15 4.22	3.0 2.7	850 1000	26.4 27.8	17.8 19.8	0.67 0.71	1.12 1.18	30.2 31.8	23.6 23.6	0.9 1.0
	6.0	3.1	7.2	850 1000	25.4 26.2	1.77 1.79	19.4 20.1	97.7 94.3	4.21 4.28	3.0 2.8	850 1000	27.0 28.4	18.0 20.0	0.67 0.71	1.05 1.11	30.6 32.2	25.6 25.7	0.9 0.9
	8.0	4.9	11.4	850 1000	26.0 26.8	1.79 1.81	19.9 20.6	98.3 94.8	4.26 4.34	3.1 2.9	850 1000	27.2 28.7	19.3 21.4	0.71 0.75	1.03 1.08	30.8 32.4	26.5 26.6	0.8 0.9
60	4.0	1.3	3.1	850 1000	26.9 27.7	1.75 1.77	20.9 21.7	99.3 95.7	4.49 4.60	3.2 3.0	850 1000	26.0 27.3	18.2 20.3	0.70 0.74	1.27 1.33	30.4 31.9	20.4 20.5	1.3 1.4
	6.0	3.0	6.9	850 1000	28.1 29.0	1.80 1.81	21.9 22.8	100.6 96.8	4.56 4.68	3.3 3.1	850 1000	26.7 27.9	18.4 20.5	0.69 0.73	1.21 1.26	30.8 32.2	22.0 22.1	1.2 1.3
	8.0	4.8	11.0	850 1000	28.8 29.7	1.82 1.83	22.5 23.5	101.3 97.5	4.62 4.76	3.4 3.2	850 1000	26.9 28.3	19.4 21.6	0.72 0.76	1.18 1.24	31.0 32.5	22.8 22.9	1.1 1.2
70	4.0	1.3	3.0	850 1000	29.2 30.7	1.78 1.84	23.2 24.4	101.8 98.4	4.82 4.89	3.6 3.3	850 1000	25.7 27.5	18.6 21.9	0.72 0.80	1.43 1.53	30.6 32.3	17.9 18.0	1.7 1.8
	6.0	2.9	6.7	850 1000	30.7 31.7	1.84 1.84	24.5 25.5	103.5 99.4	4.91 5.07	3.7 3.4	850 1000	26.3 27.5	18.8 20.9	0.72 0.76	1.37 1.42	31.0 32.5	19.2 19.4	1.6 1.7
	8.0	4.6	10.6	850 1000	31.5 32.6	1.86 1.85	25.2 26.3	104.3 100.2	4.97 5.16	3.8 3.5	850 1000	26.6 27.8	19.6 21.7	0.74 0.78	1.34 1.39	31.2 32.7	19.9 20.0	1.5 1.7
80	4.0	1.3	2.9	850 1000	31.5 32.6	1.80 1.79	25.4 26.5	104.4 100.2	5.13 5.35	4.1 3.8	850 1000	24.6 25.5	18.2 20.2	0.74 0.79	1.65 1.70	30.2 31.3	14.8 15.0	2.3 2.5
	6.0	2.8	6.5	850 1000	33.4 34.5	1.87 1.86	27.0 28.2	106.3 101.9	5.22 5.45	4.3 3.9	850 1000	25.2 26.2	18.4 20.4	0.73 0.78	1.60 1.64	30.7 31.9	15.8 16.0	2.4 2.0
	8.0	4.4	10.3	850 1000	34.3 35.5	1.90 1.87	27.8 29.1	107.4 102.9	5.30 5.56	4.4 4.1	850 1000	25.5 26.6	18.9 20.9	0.74 0.79	1.56 1.61	30.8 32.0	16.3 16.5	2.2 3.2
90	4.0	1.2	2.8	850 1000	33.9 35.1	1.83 1.80	27.6 28.9	106.9 102.5	5.43 5.71	4.7 4.4	850 1000	23.4 24.3	17.8 19.7	0.76 0.81	1.88 1.92	29.8 30.8	12.5 12.6	3.4 3.0
	6.0	2.7	6.2	850 1000	36.0 37.3	1.91 1.88	29.5 30.9	109.2 104.5	5.52 5.82	4.9 4.5	850 1000	24.1 25.0	18.0 19.9	0.75 0.80	1.82 1.87	30.3 31.4	13.2 13.4	3.2 2.8
	8.0	4.3	9.9	850 1000	37.1 38.4	1.94 1.89	30.5 32.0	110.4 105.6	5.61 5.95	5.0 4.7	850 1000	26.1 25.3	20.9 20.1	0.80 0.79	1.71 1.83	31.9 31.5	15.3 13.8	3.1 3.1
100	4.0	1.2	2.7	Operation not recommended							Operation not recommended							
	6.0	2.6	6.0	Operation not recommended							Operation not recommended							
	8.0	4.1	9.5	Operation not recommended							Operation not recommended							
110	4.0	1.1	2.6	Operation not recommended							Operation not recommended							
	6.0	2.5	5.8	Operation not recommended							Operation not recommended							
	8.0	4.0	9.2	Operation not recommended							Operation not recommended							
120	4.0	1.1	2.5	Operation not recommended							Operation not recommended							
	6.0	2.4	5.6	Operation not recommended							Operation not recommended							
	8.0	3.8	8.8	Operation not recommended							Operation not recommended							

Performance capacities shown in thousands of Btuh.

# Performance Data

## 048 - Dual Capacity with 5-Speed ECM High Speed (1700 cfm)

EWT °F	Flow gpm	WPD		HEATING - EAT 70°F							COOLING - EAT 80/67 °F							
		PSI	FT	Airflow cfm	HC kBtuh	Power kW	HE kBtuh	LAT °F	COP	HWC kBtuh	Airflow cfm	TC kBtuh	SC kBtuh	S/T Ratio	Power kW	HR kBtuh	EER	HWC kBtuh
20	6.0	7.0	16.2	Operation not recommended							Operation not recommended							
	9.0	9.7	22.4	Operation not recommended							Operation not recommended							
	12.0	12.4	28.7	1400 1700	35.2 33.4	2.95 3.05	25.2 23.0	93.3 88.2	3.50 3.21	4.7 4.2								
30	6.0	6.8	15.8	Operation not recommended							Operation not recommended							
	9.0	9.4	21.8	1400 1700	34.6 35.6	2.99 3.08	24.4 25.1	92.9 89.4	3.39 3.39	4.9 4.5	1400 1700	45.5 46.2	26.1 28.5	0.57 0.62	1.86 1.95	51.8 52.9	24.5 23.6	- -
	12.0	12.0	27.8	1400 1700	38.3 36.3	3.01 3.11	28.0 25.7	95.3 89.8	3.73 3.42	5.0 4.6	1400 1700	45.7 46.8	26.1 28.5	0.57 0.61	1.80 1.89	51.8 53.2	25.4 24.8	- -
40	6.0	6.6	15.3	Operation not recommended							Operation not recommended							
	9.0	9.1	21.1	1400 1700	40.8 42.1	3.25 3.32	29.7 30.7	97.0 92.9	3.68 3.71	5.6 5.2	1400 1700	49.4 50.3	30.6 33.4	0.62 0.66	2.18 2.29	56.8 58.1	22.6 22.0	- -
	12.0	11.7	27.0	1400 1700	41.6 43.0	3.28 3.36	30.4 31.5	97.5 93.4	3.71 3.75	5.8 5.3	1400 1700	49.7 50.9	30.6 33.4	0.61 0.66	2.12 2.22	57.0 58.4	23.5 23.0	- -
50	6.0	6.4	14.8	1400 1700	45.4 46.7	3.44 3.49	33.6 34.8	100.0 95.5	3.86 3.93	6.1 5.6	1400 1700	50.6 53.2	31.8 35.4	0.63 0.67	2.63 2.77	59.5 62.7	19.2 19.2	2.8 2.9
	9.0	8.9	20.5	1400 1700	47.0 48.5	3.52 3.57	35.0 36.4	101.1 96.4	3.92 3.99	6.3 5.8	1400 1700	51.6 54.3	32.2 35.8	0.62 0.66	2.48 2.60	60.1 63.2	20.8 20.9	2.6 2.8
	12.0	11.3	26.2	1400 1700	48.1 49.6	3.55 3.60	36.0 37.3	101.8 97.0	3.97 4.04	6.5 5.9	1400 1700	52.1 54.9	34.4 38.2	0.66 0.70	2.42 2.54	60.4 63.6	21.6 21.6	2.4 2.7
60	6.0	6.2	14.3	1400 1700	47.3 48.9	3.37 3.40	35.8 37.3	101.3 96.6	4.11 4.22	6.9 6.4	1400 1700	49.2 51.6	32.7 36.3	0.66 0.70	2.85 2.98	58.9 61.7	17.3 17.3	3.2 3.5
	9.0	8.6	19.8	1400 1700	49.5 51.1	3.47 3.49	37.6 39.2	102.7 97.8	4.18 4.29	7.1 6.6	1400 1700	50.4 52.7	33.1 36.7	0.66 0.70	2.71 2.82	59.6 62.4	18.6 18.7	3.1 3.3
	12.0	11.0	25.3	1400 1700	50.7 52.4	3.51 3.52	38.7 40.3	103.5 98.5	4.24 4.36	7.3 6.7	1400 1700	50.8 53.4	34.8 38.7	0.69 0.72	2.64 2.76	59.9 62.8	19.3 19.3	2.8 3.2
70	6.0	6.0	13.9	1400 1700	49.4 51.9	3.30 3.37	38.1 40.4	102.7 98.3	4.38 4.51	7.9 7.3	1400 1700	47.8 50.9	33.5 39.0	0.70 0.77	3.07 3.24	58.3 61.5	17.5 15.7	4.0 4.3
	9.0	8.3	19.2	1400 1700	52.0 53.6	3.41 3.41	40.3 42.0	104.4 99.2	4.46 4.61	8.1 7.5	1400 1700	49.1 51.2	33.9 37.6	0.69 0.73	2.94 3.04	59.1 61.8	16.7 16.8	3.8 4.1
	12.0	10.6	24.5	1400 1700	53.3 55.1	3.45 3.44	41.5 43.4	105.2 100.0	4.52 4.69	8.4 7.7	1400 1700	49.6 51.8	35.3 39.1	0.71 0.75	2.86 2.98	59.3 62.0	17.3 17.4	3.5 3.9
80	6.0	5.8	13.4	1400 1700	51.6 53.4	3.37 3.35	40.1 42.0	104.1 99.1	4.48 4.68	8.7 8.1	1400 1700	45.3 47.1	33.2 36.9	0.73 0.78	3.38 3.49	56.8 59.0	13.4 13.5	5.2 5.5
	9.0	8.0	18.5	1400 1700	54.6 56.5	3.51 3.47	42.6 44.6	106.1 100.8	4.56 4.76	9.0 8.3	1400 1700	46.5 48.4	33.6 37.3	0.72 0.77	3.27 3.36	57.7 59.9	14.2 14.4	4.8 5.2
	12.0	10.2	23.7	1400 1700	56.2 58.1	3.55 3.50	44.1 46.2	107.2 101.6	4.63 4.87	9.3 8.6	1400 1700	47.0 49.0	34.4 38.2	0.73 0.78	3.20 3.30	57.9 60.2	14.7 14.9	4.5 5.0
90	6.0	5.6	12.9	1400 1700	53.9 55.8	3.44 3.39	42.1 44.2	105.6 100.4	4.59 4.82	9.7 9.0	1400 1700	42.7 44.2	32.9 36.5	0.77 0.83	3.70 3.79	55.3 57.1	11.5 11.7	6.4 6.8
	9.0	7.7	17.9	1400 1700	57.3 59.3	3.60 3.53	45.0 47.2	107.9 102.3	4.66 4.92	10.0 9.3	1400 1700	44.0 45.6	33.3 36.9	0.76 0.81	3.59 3.69	56.2 58.2	12.2 12.4	6.0 6.5
	12.0	9.9	22.8	1400 1700	59.1 61.1	3.65 3.56	46.6 49.0	109.1 103.3	4.74 5.03	10.3 9.6	1400 1700	45.2 46.1	33.3 37.2	0.74 0.81	3.20 3.61	56.1 58.4	14.1 12.8	5.6 6.2
100	6.0	5.4	12.5	Operation not recommended							Operation not recommended							
	9.0	7.5	17.2	Operation not recommended							Operation not recommended							
	12.0	9.5	22.0	Operation not recommended							Operation not recommended							
110	6.0	5.2	12.0	Operation not recommended							Operation not recommended							
	9.0	7.2	16.6	Operation not recommended							Operation not recommended							
	12.0	9.2	21.2	Operation not recommended							Operation not recommended							
120	6.0	5.0	11.5	Operation not recommended							Operation not recommended							
	9.0	6.9	15.9	Operation not recommended							Operation not recommended							
	12.0	8.8	20.3	Operation not recommended							Operation not recommended							

Performance capacities shown in thousands of Btuh.

# Performance Data

## 048 - Dual Capacity with 5-Speed ECM Low Speed (1250 cfm)

EWT °F	Flow gpm	WPD		HEATING - EAT 70°F							COOLING - EAT 80/67 °F							
		PSI	FT	Airflow cfm	HC kBtuh	Power kW	HE kBtuh	LAT °F	COP	HWC kBtuh	Airflow cfm	TC kBtuh	SC kBtuh	S/T Ratio	Power kW	HR kBtuh	EER	HWC kBtuh
20	5.0	5.7	13.3	Operation not recommended							Operation not recommended							
	8.0	8.2	18.9	Operation not recommended							Operation not recommended							
	11.0	10.4	24.1	1000 1250	23.9 22.1	2.36 2.22	15.8 14.5	92.1 86.4	2.97 2.92	4.4 4.0	Operation not recommended							
30	5.0	5.6	12.9	Operation not recommended							Operation not recommended							
	8.0	8.0	18.4	1000 1250	22.5 23.5	2.01 2.07	15.7 16.4	90.9 87.4	3.28 3.33	4.4 4.0	1000 1250	32.9 33.5	25.0 27.3	0.76 0.82	1.07 1.13	36.6 37.3	30.8 29.7	- -
	11.0	10.1	23.4	1000 1250	27.0 25.0	2.25 2.12	19.3 17.8	95.0 88.5	3.52 3.46	4.5 4.1	1000 1250	33.1 33.9	25.0 27.3	0.75 0.81	1.04 1.09	36.6 37.6	31.9 31.1	- -
40	5.0	5.4	12.5	Operation not recommended							Operation not recommended							
	8.0	7.7	17.8	1000 1250	27.4 28.4	2.12 2.16	20.2 21.0	95.4 91.0	3.79 3.84	4.6 4.2	1000 1250	35.4 36.0	25.2 27.6	0.71 0.76	1.18 1.24	39.4 40.3	29.9 29.1	- -
	11.0	9.8	22.7	1000 1250	28.9 29.9	2.17 2.22	21.5 22.3	96.8 92.1	3.90 3.96	4.7 4.3	1000 1250	35.7 36.5	25.2 27.6	0.71 0.76	1.15 1.20	39.6 40.5	31.1 30.4	- -
50	5.0	5.2	12.1	1000 1250	31.2 32.2	2.23 2.26	23.6 24.5	98.9 93.8	4.10 4.17	4.8 4.5	1000 1250	37.0 38.0	24.3 26.9	0.66 0.71	1.33 1.35	41.5 42.6	27.8 28.2	1.5 1.6
	8.0	7.5	17.3	1000 1250	32.3 33.3	2.23 2.26	24.7 25.6	99.9 94.6	4.24 4.32	5.0 4.6	1000 1250	37.3 38.4	24.5 27.1	0.66 0.71	1.30 1.32	41.8 42.9	28.8 29.0	1.4 1.6
	11.0	9.5	22.0	1000 1250	33.8 34.8	2.28 2.31	26.0 26.9	101.3 95.8	4.34 4.42	5.1 4.7	1000 1250	37.9 39.0	25.1 27.8	0.66 0.71	1.29 1.31	42.3 43.5	29.5 29.8	1.3 1.5
60	5.0	5.1	11.7	1000 1250	33.4 34.2	2.18 2.19	26.0 26.7	100.9 95.3	4.49 4.57	5.3 4.9	1000 1250	35.7 36.7	24.5 27.1	0.69 0.74	1.53 1.56	41.0 42.0	23.3 23.5	2.1 2.3
	8.0	7.2	16.7	1000 1250	34.7 35.5	2.18 2.19	27.3 28.1	102.2 96.3	4.68 4.76	5.4 5.0	1000 1250	36.0 37.0	24.6 27.3	0.68 0.74	1.49 1.52	41.1 42.2	24.1 24.3	2.0 2.2
	11.0	9.2	21.3	1000 1250	35.9 36.8	2.22 2.24	28.4 29.1	103.3 97.2	4.74 4.82	5.6 5.1	1000 1250	36.6 37.7	25.3 28.0	0.69 0.74	1.48 1.51	41.7 42.8	24.7 24.9	1.9 2.1
70	5.0	4.9	11.3	1000 1250	35.5 36.6	2.13 2.17	28.3 29.2	102.9 97.1	4.90 4.94	5.8 5.4	1000 1250	34.4 35.4	24.6 27.8	0.71 0.79	1.74 1.90	40.4 41.6	19.8 18.6	3.0 3.1
	8.0	7.0	16.2	1000 1250	37.1 37.8	2.12 2.12	29.8 30.5	104.3 98.0	5.13 5.23	6.0 5.6	1000 1250	34.7 35.7	24.8 27.4	0.71 0.77	1.69 1.73	40.5 41.9	20.5 20.7	2.8 3.0
	11.0	8.9	20.6	1000 1250	41.4 38.7	2.33 2.16	33.5 31.3	108.3 98.7	5.21 5.25	6.2 5.7	1000 1250	35.3 36.3	25.4 28.1	0.72 0.77	1.68 1.71	41.0 42.1	21.1 21.2	2.6 2.8
80	5.0	4.7	10.9	1000 1250	38.6 39.1	2.19 2.18	31.1 31.7	105.7 99.0	5.16 5.26	6.6 6.1	1000 1250	33.1 34.0	24.2 26.8	0.73 0.79	2.01 2.05	40.0 41.0	16.5 16.6	4.0 4.3
	8.0	6.8	15.6	1000 1250	40.5 40.9	2.18 2.16	33.0 33.6	107.5 100.3	5.44 5.55	6.8 6.3	1000 1250	33.4 34.3	24.3 26.9	0.73 0.78	1.96 2.00	40.1 41.2	17.0 17.2	3.7 4.1
	11.0	8.6	19.9	1000 1250	41.0 41.5	2.22 2.21	33.4 33.9	108.0 100.7	5.40 5.51	7.0 6.5	1000 1250	34.0 34.9	24.9 27.6	0.73 0.79	1.94 1.98	40.6 41.7	17.5 17.6	3.5 3.9
90	5.0	4.6	10.5	1000 1250	41.7 42.0	2.26 2.23	33.9 34.4	108.6 101.1	5.40 5.51	7.5 7.0	1000 1250	31.8 32.7	23.7 26.3	0.75 0.80	2.29 2.33	39.6 40.6	13.9 14.0	5.4 5.7
	8.0	6.5	15.1	1000 1250	43.8 44.1	2.24 2.21	36.2 36.5	110.6 102.7	5.73 5.85	7.8 7.2	1000 1250	32.1 33.0	23.9 26.4	0.74 0.80	2.23 2.27	39.7 40.7	14.4 14.5	5.0 5.5
	11.0	8.3	19.2	1000 1250	44.0 44.2	2.29 2.25	36.2 36.5	110.7 102.7	5.64 5.76	8.0 7.4	1000 1250	34.8 33.5	27.3 27.1	0.78 0.81	2.38 2.25	42.9 41.9	14.6 14.9	4.7 5.2
100	5.0	4.4	10.2	Operation not recommended							Operation not recommended							
	8.0	6.3	14.5	Operation not recommended							Operation not recommended							
	11.0	8.0	18.5	1000 1250	30.8 31.7	2.51 2.78	0.81 0.88	2.66 2.71	39.9 40.9	11.6 11.7	6.0 6.6	Operation not recommended						
110	5.0	4.2	9.8	Operation not recommended							Operation not recommended							
	8.0	6.0	14.0	Operation not recommended							Operation not recommended							
	11.0	7.7	17.8	1000 1250	28.6 29.4	2.50 2.77	0.87 0.94	3.14 3.20	39.3 40.3	9.1 9.2	8.5 9.2	Operation not recommended						
120	5.0	4.1	9.4	Operation not recommended							Operation not recommended							
	8.0	5.8	13.4	Operation not recommended							Operation not recommended							
	11.0	7.4	17.1	1000 1250	25.1 25.6	2.18 2.37	0.87 0.93	3.22 3.32	36.0 36.9	7.8 7.7	9.7 10.8	Operation not recommended						

Performance capacities shown in thousands of Btuh.

# Performance Data

## 060 - Dual Capacity with 5-Speed ECM High Speed (1800 cfm)

EWT °F	Flow gpm	WPD		HEATING - EAT 70°F							COOLING - EAT 80/67 °F							
		PSI	FT	Airflow cfm	HC kBtuh	Power kW	HE kBtuh	LAT °F	COP	HWC kBtuh	Airflow cfm	TC kBtuh	SC kBtuh	S/T Ratio	Power kW	HR kBtuh	EER	HWC kBtuh
20	8.0	7.5	17.3	Operation not recommended							Operation not recommended							
	12.0	11.9	27.6	Operation not recommended							Operation not recommended							
	16.0	16.4	37.9	1500 1800	36.2 37.5	3.32 3.47	24.8 25.7	92.3 89.3	3.19 3.17	5.2 4.7	Operation not recommended							
30	8.0	7.3	16.8	Operation not recommended							Operation not recommended							
	12.0	11.6	26.8	1500 1800	45.7 47.6	4.16 4.27	31.5 33.1	98.2 94.5	3.22 3.27	5.5 5.1	1500 1800	52.1 52.9	37.7 41.2	0.72 0.78	2.46 2.59	60.4 61.7	21.2 20.5	- -
	16.0	15.9	36.8	1500 1800	48.9 50.7	4.19 4.38	34.6 35.8	100.2 96.1	3.42 3.39	5.8 5.2	1500 1800	52.3 53.6	37.7 41.2	0.72 0.77	2.38 2.50	60.4 62.1	22.0 21.4	- -
40	8.0	7.1	16.3	Operation not recommended							Operation not recommended							
	12.0	11.2	26.0	1500 1800	51.4 53.2	4.14 4.22	37.2 38.7	101.7 97.3	3.63 3.69	6.1 5.7	1500 1800	56.1 57.2	38.8 42.4	0.69 0.74	2.78 2.91	65.6 67.1	20.2 19.6	- -
	16.0	15.4	35.7	1500 1800	54.1 56.0	4.24 4.33	39.7 41.2	103.4 98.8	3.74 3.79	6.6 6.0	1500 1800	56.6 57.9	38.8 42.4	0.69 0.73	2.70 2.82	65.8 67.5	21.0 20.5	- -
50	8.0	6.8	15.8	1500 1800	54.9 56.7	4.12 4.18	40.9 42.4	103.9 99.1	3.91 3.97	6.9 6.4	1500 1800	58.9 60.5	38.1 42.2	0.65 0.70	3.19 3.05	69.8 71.0	18.5 23.3	3.6 3.8
	12.0	10.9	25.2	1500 1800	56.9 58.6	4.12 4.18	42.8 44.3	105.1 100.1	4.04 4.11	7.2 6.6	1500 1800	59.4 61.1	38.3 42.4	0.64 0.69	3.11 3.17	70.0 71.9	19.1 19.3	3.3 3.6
	16.0	15.0	34.6	1500 1800	59.5 61.3	4.22 4.27	45.1 46.7	106.8 101.5	4.14 4.21	7.4 6.8	1500 1800	60.4 62.1	39.3 43.5	0.65 0.70	3.08 3.14	70.9 72.8	19.6 19.8	3.1 3.4
60	8.0	6.6	15.3	1500 1800	62.3 63.9	4.53 4.56	46.9 48.3	108.5 102.9	4.03 4.10	7.8 7.2	1500 1800	57.8 59.4	37.7 41.7	0.65 0.70	3.44 3.51	69.6 71.4	16.8 17.0	4.4 4.6
	12.0	10.5	24.4	1500 1800	64.8 66.4	4.52 4.55	49.4 50.8	110.0 104.1	4.20 4.28	8.1 7.4	1500 1800	58.3 60.0	37.9 42.0	0.65 0.70	3.35 3.42	69.8 71.6	17.4 17.6	4.1 4.4
	16.0	14.5	33.5	1500 1800	67.1 68.6	4.62 4.65	51.3 52.8	111.4 105.3	4.25 4.33	8.5 7.6	1500 1800	59.3 61.0	38.9 43.1	0.66 0.71	3.32 3.39	70.6 72.5	17.9 18.0	3.8 4.2
70	8.0	6.4	14.8	1500 1800	69.7 71.2	4.94 4.87	52.8 54.6	113.0 106.6	4.13 4.28	8.9 8.2	1500 1800	56.7 57.9	37.3 41.1	0.66 0.71	3.69 3.94	69.3 71.3	15.4 14.7	5.4 5.7
	12.0	10.2	23.6	1500 1800	72.7 74.1	4.92 4.92	55.9 57.3	114.9 108.1	4.33 4.41	9.2 8.4	1500 1800	57.2 58.8	37.5 41.5	0.66 0.71	3.59 3.66	69.5 71.5	15.9 16.1	5.0 5.4
	16.0	14.0	32.4	1500 1800	74.6 75.9	5.03 5.02	57.4 58.8	116.1 109.0	4.35 4.43	9.5 8.7	1500 1800	58.2 59.8	38.5 42.6	0.66 0.71	3.56 3.63	70.3 72.2	16.3 16.5	4.7 5.2
80	8.0	6.2	14.3	1500 1800	76.6 77.7	5.15 5.12	59.1 60.2	117.3 110.0	4.36 4.44	9.8 9.1	1500 1800	55.3 56.8	37.1 41.1	0.67 0.72	4.08 4.16	69.2 71.0	13.5 13.6	7.0 7.4
	12.0	9.9	22.8	1500 1800	80.3 81.3	5.12 5.08	62.9 63.9	119.6 111.8	4.60 4.69	10.2 9.4	1500 1800	55.8 57.3	37.3 41.3	0.67 0.72	3.98 4.06	69.3 71.1	14.0 14.1	6.5 7.0
	16.0	13.5	31.3	1500 1800	81.5 82.3	5.23 5.18	63.6 64.6	120.3 112.3	4.57 4.66	10.5 9.6	1500 1800	56.7 58.3	38.3 42.4	0.68 0.73	3.94 4.02	70.1 72.0	14.4 14.5	6.0 6.7
90	8.0	6.0	13.8	1500 1800	83.6 84.3	5.37 5.30	65.3 66.2	121.6 113.4	4.57 4.66	10.9 10.0	1500 1800	53.8 55.3	36.9 40.8	0.69 0.74	4.48 4.57	69.1 70.9	12.0 12.1	9.1 9.7
	12.0	9.5	22.0	1500 1800	87.9 88.5	5.32 5.24	69.8 70.6	124.3 115.5	4.84 4.94	11.2 10.4	1500 1800	54.3 55.8	37.1 41.1	0.68 0.74	4.36 4.45	69.2 71.0	12.4 12.5	8.5 9.2
	16.0	13.0	30.1	1500 1800	88.3 88.7	5.43 5.34	69.8 70.5	124.5 115.6	4.77 4.87	11.6 10.8	1500 1800	58.1 56.7	39.4 42.1	0.68 0.74	4.17 4.41	72.3 71.7	13.9 12.9	7.9 8.8
100	8.0	5.7	13.3	Operation not recommended							Operation not recommended							
	12.0	9.2	21.2	Operation not recommended							Operation not recommended							
	16.0	12.6	29.1	Operation not recommended							1500 1800	52.3 53.8	36.9 40.8	0.70 0.76	4.81 4.90	68.7 70.5	10.9 11.0	10.2 11.0
110	8.0	5.5	12.8	Operation not recommended							Operation not recommended							
	12.0	8.8	20.4	Operation not recommended							Operation not recommended							
	16.0	12.1	28.0	Operation not recommended							1500 1800	50.4 51.7	36.6 40.6	0.73 0.78	5.25 5.35	68.2 70.0	9.6 9.7	13.2 14.2
120	8.0	5.3	12.3	Operation not recommended							Operation not recommended							
	12.0	8.5	19.6	Operation not recommended							Operation not recommended							
	16.0	11.6	26.9	Operation not recommended							1500 1800	46.9 47.7	36.1 39.2	0.77 0.82	5.89 6.04	67.0 68.4	8.0 7.9	15.6 16.3

Performance capacities shown in thousands of Btuh.

# Performance Data

## 060 - Dual Capacity with 5-Speed ECM Low Speed (1500 cfm)

EWT °F	Flow gpm	WPD		HEATING - EAT 70°F							COOLING - EAT 80/67 °F							
		PSI	FT	Airflow cfm	HC kBtuh	Power kW	HE kBtuh	LAT °F	COP	HWC kBtuh	Airflow cfm	TC kBtuh	SC kBtuh	S/T Ratio	Power kW	HR kBtuh	EER	HWC kBtuh
20	6.0	4.4	10.3	Operation not recommended							Operation not recommended							
	10.0	8.7	20.0	Operation not recommended							Operation not recommended							
	14.0	13.1	30.3	1250 1500	24.1 26.2	2.61 2.76	15.2 16.8	87.8 86.2	2.71 2.78	4.1 3.8	Operation not recommended							
30	6.0	4.3	10.0	Operation not recommended							Operation not recommended							
	10.0	8.4	19.4	1250 1500	30.9 32.2	2.91 2.99	21.0 22.0	92.9 89.9	3.12 3.16	4.1 3.7	1250 1500	39.6 40.3	32.4 35.4	0.82 0.88	1.65 1.74	45.3 46.2	24.0 23.2	- -
	14.0	12.7	29.4	1250 1500	31.5 34.3	2.89 3.06	21.6 23.9	93.3 91.2	3.19 3.29	4.2 3.8	1250 1500	39.8 40.8	32.4 35.4	0.81 0.87	1.60 1.68	45.3 46.5	24.9 24.3	- -
40	6.0	4.2	9.7	Operation not recommended							Operation not recommended							
	10.0	8.2	18.8	1250 1500	36.2 37.4	2.90 2.95	26.3 27.4	96.8 93.1	3.66 3.71	4.6 4.1	1250 1500	43.1 43.9	31.9 34.9	0.74 0.79	1.76 1.85	49.2 50.3	24.5 23.8	- -
	14.0	12.3	28.5	1250 1500	38.1 39.5	2.97 3.03	28.0 29.1	98.3 94.4	3.76 3.82	4.7 4.3	1250 1500	43.5 44.5	31.9 34.9	0.73 0.78	1.71 1.79	49.3 50.6	25.4 24.8	- -
50	6.0	4.1	9.4	1250 1500	40.0 41.2	2.89 2.93	30.1 31.2	99.6 95.4	4.06 4.13	4.8 4.4	1250 1500	45.6 46.9	30.0 33.3	0.66 0.71	1.98 1.74	52.4 52.8	23.0 32.5	1.9 2.0
	10.0	7.9	18.3	1250 1500	41.4 42.6	2.89 2.92	31.5 32.7	100.7 96.3	4.20 4.27	5.0 4.6	1250 1500	46.0 47.3	30.2 33.4	0.66 0.71	1.93 1.97	52.6 54.0	23.9 24.1	1.8 1.9
	14.0	12.0	27.6	1250 1500	43.3 44.6	2.95 2.99	33.2 34.4	102.1 97.5	4.30 4.37	5.2 4.8	1250 1500	46.8 48.1	31.0 34.3	0.66 0.71	1.91 1.95	53.3 54.8	24.5 24.7	1.6 1.8
60	6.0	3.9	9.1	1250 1500	44.1 45.2	3.04 3.06	33.7 34.7	102.6 97.9	4.25 4.32	5.6 5.0	1250 1500	44.4 45.6	30.3 33.5	0.68 0.73	2.17 2.21	51.8 53.2	20.5 20.6	2.6 2.8
	10.0	7.7	17.7	1250 1500	45.8 46.9	3.04 3.05	35.5 36.5	104.0 99.0	4.42 4.50	5.6 5.2	1250 1500	44.8 46.0	30.4 33.7	0.68 0.73	2.11 2.15	52.0 53.4	21.2 21.4	2.5 2.7
	14.0	11.6	26.8	1250 1500	47.4 48.5	3.11 3.12	36.8 37.9	105.1 99.9	4.48 4.56	5.8 5.3	1250 1500	45.5 46.8	31.2 34.6	0.69 0.74	2.09 2.14	52.7 54.1	21.7 21.9	2.3 2.5
70	6.0	3.8	8.8	1250 1500	48.1 48.8	3.20 3.21	37.2 37.8	105.6 100.1	4.41 4.46	6.2 5.7	1250 1500	43.2 44.5	30.5 33.9	0.71 0.76	2.36 2.67	51.2 52.7	18.3 16.7	3.7 3.9
	10.0	7.4	17.1	1250 1500	50.2 51.1	3.19 3.19	39.3 40.3	107.2 101.6	4.62 4.70	6.5 5.9	1250 1500	43.6 44.8	30.7 33.9	0.70 0.76	2.30 2.34	51.4 53.4	19.0 19.1	3.4 3.7
	14.0	11.2	25.9	1250 1500	51.5 52.4	3.26 3.25	40.4 41.3	108.2 102.3	4.64 4.73	6.7 6.1	1250 1500	44.3 45.5	31.4 34.8	0.71 0.76	2.28 2.32	52.0 5.6	19.5 19.6	3.2 3.5
80	6.0	3.7	8.5	1250 1500	53.6 54.4	3.25 3.23	42.5 43.3	109.7 103.6	4.83 4.93	6.9 6.4	1250 1500	41.3 42.4	29.7 32.9	0.72 0.78	2.71 2.76	50.5 51.8	15.2 15.4	5.1 5.4
	10.0	7.1	16.5	1250 1500	56.2 56.9	3.23 3.21	45.2 45.9	111.6 105.1	5.10 5.20	7.2 6.7	1250 1500	41.6 42.8	29.9 33.1	0.72 0.77	2.64 2.69	50.6 52.0	15.8 15.9	4.8 5.2
	14.0	10.8	25.0	1250 1500	57.0 57.6	3.30 3.27	45.8 46.4	112.2 105.6	5.06 5.16	7.4 6.8	1250 1500	42.3 43.5	30.7 34.0	0.72 0.78	2.61 2.67	51.2 52.6	16.2 16.3	4.4 4.9
90	6.0	3.5	8.2	1250 1500	59.2 59.7	3.31 3.27	47.9 48.5	113.8 106.8	5.25 5.35	7.8 7.2	1250 1500	39.4 40.5	29.0 32.1	0.74 0.79	3.06 3.12	49.8 51.1	12.9 13.0	6.8 7.2
	10.0	6.9	15.9	1250 1500	62.2 62.6	3.28 3.23	51.1 51.6	116.1 108.7	5.57 5.68	8.1 7.4	1250 1500	39.7 40.8	29.2 32.3	0.73 0.79	2.98 3.04	49.9 51.2	13.3 13.4	6.4 6.9
	14.0	10.4	24.1	1250 1500	62.5 62.8	3.34 3.29	51.1 51.6	116.3 108.8	5.48 5.59	8.3 7.8	1250 1500	40.6 41.5	30.6 33.1	0.75 0.80	2.88 3.01	50.4 51.8	14.1 13.8	5.9 6.6
100	6.0	3.4	7.9	Operation not recommended							Operation not recommended							
	10.0	6.6	15.4	Operation not recommended							Operation not recommended							
	14.0	10.1	23.2	1250 1500	36.9 37.9	28.5 31.5	0.77 0.83	3.38 3.45	48.4 49.6	10.9 11.0	8.3 8.9	1250 1500	37.5 38.5	29.2 32.3	0.78 0.84	3.35 3.42	48.9 50.2	11.2 11.3
110	6.0	3.3	7.6	Operation not recommended							Operation not recommended							
	10.0	6.4	14.8	Operation not recommended							Operation not recommended							
	14.0	9.7	22.4	1250 1500	34.0 34.9	27.8 30.7	0.82 0.88	3.78 3.85	46.9 48.1	9.0 9.1	10.4 11.3	1250 1500	34.5 35.5	28.5 31.5	0.82 0.89	3.75 3.82	47.3 48.5	9.2 9.3
120	6.0	3.2	7.3	Operation not recommended							Operation not recommended							
	10.0	6.1	14.2	Operation not recommended							Operation not recommended							
	14.0	9.3	21.5	1250 1500	31.3 31.9	27.3 29.6	0.87 0.93	4.32 4.43	46.1 47.0	7.3 7.2	12.6 13.6	1250 1500	31.6 32.3	27.3 29.6	0.86 0.92	4.18 4.31	45.9 47.0	7.6 7.5

Performance capacities shown in thousands of Btuh.

# Performance Data

## 072 - Dual Capacity with 5-Speed ECM High Speed (2300 cfm)

EWT °F	Flow gpm	WPD		HEATING - EAT 70°F							COOLING - EAT 80/67 °F								
		PSI	FT	Airflow cfm	HC kBtuh	Power kW	HE kBtuh	LAT °F	COP	HWC kBtuh	Airflow cfm	TC kBtuh	SC kBtuh	S/T Ratio	Power kW	HR kBtuh	EER	HWC kBtuh	
20	12.0	4.0	9.1	Operation not recommended							Operation not recommended								
	15.0	5.9	13.5	Operation not recommended							Operation not recommended								
	18.0	8.1	18.7	1850 2300	43.8 45.6	4.24 4.42	29.3 30.5	91.9 88.4	3.03 3.02	7.9 7.1									
30	12.0	3.8	8.9	Operation not recommended							Operation not recommended								
	15.0	5.7	13.1	1850 2300	55.2 56.8	4.77 4.92	38.9 40.0	97.6 92.9	3.39 3.38	8.3 7.6	1850 2300	57.2 58.1	42.7 46.7	0.75 0.80	3.19 3.36	68.1 69.6	17.9 17.3	- -	
	18.0	7.8	18.1	1850 2300	55.6 57.9	4.77 4.97	39.3 40.9	97.8 93.3	3.42 3.41	8.5 7.7	1850 2300	57.5 58.9	42.7 46.7	0.74 0.79	3.10 3.25	68.1 70.0	18.6 18.1	- -	
40	12.0	3.7	8.6	Operation not recommended							Operation not recommended								
	15.0	5.5	12.7	1850 2300	62.4 64.3	4.84 4.94	45.9 47.4	101.2 95.9	3.78 3.81	9.2 8.4	1850 2300	62.1 63.2	43.2 47.1	0.70 0.74	3.44 3.61	73.8 75.6	18.0 17.5	- -	
	18.0	7.6	17.6	1850 2300	63.6 65.7	4.89 4.99	47.0 48.6	101.8 96.4	3.82 3.86	9.5 8.6	1850 2300	62.6 64.0	43.2 47.1	0.69 0.74	3.34 3.50	74.0 75.9	18.7 18.3	- -	
50	12.0	3.6	8.3	1850 2300	67.2 69.2	4.79 4.86	50.8 52.6	103.6 97.8	4.11 4.17	9.9 9.2	1850 2300	63.5 66.9	39.6 44.0	0.62 0.66	3.87 4.08	76.8 80.8	16.4 16.4	4.3 4.5	
	15.0	5.3	12.3	1850 2300	69.6 71.8	4.90 4.97	52.9 54.9	104.8 98.9	4.16 4.24	10.2 9.4	1850 2300	64.9 68.2	40.1 44.5	0.62 0.65	3.65 3.83	77.4 81.3	17.8 17.8	4.0 4.3	
	18.0	7.4	17.0	1850 2300	71.2 73.4	4.94 5.01	54.3 56.3	105.6 99.5	4.22 4.29	10.5 9.6	1850 2300	65.5 69.0	42.8 47.5	0.65 0.69	3.56 3.74	77.7 81.8	18.4 18.4	3.7 4.1	
60	12.0	3.5	8.1	1850 2300	73.7 76.1	5.08 5.12	56.4 58.6	106.9 100.6	4.25 4.36	11.1 10.3	1850 2300	62.3 65.4	40.5 45.1	0.65 0.69	4.21 4.39	76.7 80.3	14.8 14.9	5.5 5.5	
	15.0	5.2	11.9	1850 2300	77.0 79.5	5.23 5.26	59.2 61.6	108.6 102.0	4.32 4.43	11.5 10.6	1850 2300	63.8 66.8	41.0 45.5	0.64 0.68	4.00 4.16	77.4 81.0	16.0 16.1	4.9 5.3	
	18.0	7.1	16.5	1850 2300	78.9 81.5	5.28 5.31	60.9 63.4	109.5 102.8	4.38 4.50	11.8 10.9	1850 2300	64.4 67.6	43.2 48.0	0.67 0.71	3.90 4.08	77.7 81.5	16.5 16.6	4.5 5.0	
70	12.0	3.4	7.8	1850 2300	80.3 86.2	5.38 5.52	62.0 67.4	110.2 104.7	4.38 4.58	12.5 11.6	1850 2300	61.1 66.0	41.5 48.5	0.68 0.73	4.54 4.57	76.6 80.8	17.5 14.4	6.6 6.9	
	15.0	5.0	11.6	1850 2300	84.5 87.2	5.56 5.56	65.5 68.3	112.3 105.1	4.46 4.60	12.9 11.9	1850 2300	62.7 65.4	42.0 46.6	0.67 0.71	4.35 4.50	77.5 81.2	14.4 14.5	6.1 6.6	
	18.0	6.9	15.9	1850 2300	86.6 89.6	5.62 5.60	67.5 70.5	113.4 106.1	4.52 4.69	13.3 12.3	1850 2300	63.3 66.2	43.7 48.4	0.69 0.73	4.24 4.41	77.8 81.6	15.0 15.0	5.7 6.3	
80	12.0	3.3	7.5	1850 2300	86.8 89.8	5.60 5.56	67.7 70.8	113.4 106.2	4.54 4.74	13.9 12.8	1850 2300	59.1 61.5	41.8 46.5	0.71 0.76	4.96 5.11	76.0 78.9	11.9 12.0	8.4 8.9	
	15.0	4.8	11.2	1850 2300	91.8 94.9	5.82 5.77	71.9 75.2	115.9 108.2	4.62 4.82	14.3 13.2	1850 2300	60.8 63.2	42.4 47.0	0.70 0.74	4.78 4.92	77.1 80.0	12.7 12.8	7.8 8.4	
	18.0	6.7	15.4	1850 2300	94.4 97.7	5.90 5.81	74.3 77.8	117.3 109.3	4.69 4.93	14.7 13.6	1850 2300	61.4 64.0	43.4 48.1	0.71 0.75	4.68 4.83	77.4 80.4	13.1 13.3	7.2 8.0	
90	12.0	3.1	7.3	1850 2300	93.2 96.5	5.82 5.74	73.3 76.9	116.6 108.9	4.69 4.93	15.4 14.3	1850 2300	57.1 59.2	42.2 46.9	0.74 0.79	5.37 5.50	75.5 77.9	10.6 10.8	10.5 11.1	
	15.0	4.7	10.8	1850 2300	99.1 102.6	6.09 5.98	78.3 82.2	119.6 111.3	4.77 5.03	15.9 14.7	1850 2300	58.8 61.0	42.8 47.4	0.73 0.78	5.22 5.35	76.6 79.3	11.3 11.4	9.8 10.6	
	18.0	6.4	14.9	1850 2300	102.2 105.7	6.17 6.02	81.1 85.2	121.1 112.6	4.85 5.15	16.4 15.2	1850 2300	68.5 61.7	47.7 47.8	0.70 0.77	4.96 5.24	85.4 79.6	13.8 11.8	9.1 10.1	
100	12.0	3.0	7.0	Operation not recommended							Operation not recommended								
	15.0	4.5	10.4	1850 2300	58.2 60.1	43.9 48.7	0.75 0.81	5.84 5.93	78.1 80.4	10.0 10.1	12.2 13.2	1850 2300	58.8 60.8	43.8 48.5	0.74 0.80	5.74 5.83	78.4 80.6	10.3 10.4	11.3 12.5
	18.0	6.2	14.3	Operation not recommended							Operation not recommended								
110	12.0	2.9	6.7	Operation not recommended							Operation not recommended								
	15.0	4.3	10.0	Operation not recommended							Operation not recommended								
	18.0	6.0	13.8	Operation not recommended							Operation not recommended								
120	12.0	2.8	6.5	Operation not recommended							Operation not recommended								
	15.0	4.2	9.6	Operation not recommended							Operation not recommended								
	18.0	5.7	13.2	1850 2300	54.2 55.1	42.6 46.2	0.79 0.84	7.01 7.20	78.1 79.7	7.7 7.7	18.0 19.5	1850 2300	54.6 55.8	42.6 46.2	0.78 0.83	6.79 7.00	77.8 79.7	8.1 8.0	16.7 18.5

Performance capacities shown in thousands of Btuh.

## Performance Data

### 072 - Dual Capacity with 5-Speed ECM Low Speed (1850 cfm)

EWT °F	Flow gpm	WPD		HEATING - EAT 70°F							COOLING - EAT 80/67 °F							
		PSI	FT	Airflow cfm	HC kBtuh	Power kW	HE kBtuh	LAT °F	COP	HWC kBtuh	Airflow cfm	TC kBtuh	SC kBtuh	S/T Ratio	Power kW	HR kBtuh	EER	HWC kBtuh
20	10.0	2.9	6.8	Operation not recommended							Operation not recommended							
	13.0	4.9	11.4	Operation not recommended							Operation not recommended							
	16.0	7.0	16.2	1650 1850	33.9 34.8	3.44 3.48	22.1 22.9	89.0 87.4	2.88 2.93	5.9 5.3	Operation not recommended							
30	10.0	2.8	6.6	Operation not recommended							Operation not recommended							
	13.0	4.8	11.0	1650 1850	37.4 39.0	3.48 3.57	25.6 26.8	91.0 89.5	3.15 3.20	5.5 4.7	1650 1850	48.8 49.5	34.1 37.3	0.70 0.75	1.95 2.06	55.4 56.6	24.9 24.1	- -
	16.0	6.8	15.8	1650 1850	40.4 41.5	3.62 3.66	28.0 29.0	92.7 90.8	3.27 3.32	5.0 5.7	1650 1850	49.0 50.2	34.1 37.3	0.70 0.74	1.90 1.99	55.5 57.0	25.9 25.2	- -
40	10.0	2.8	6.4	Operation not recommended							Operation not recommended							
	13.0	4.6	10.7	1650 1850	44.0 45.6	3.54 3.61	31.9 33.2	94.7 92.8	3.64 3.70	6.5 5.9	1650 1850	51.3 52.3	35.5 38.7	0.69 0.74	2.10 2.20	58.5 59.8	24.5 23.8	- -
	16.0	6.6	15.3	1650 1850	46.4 48.0	3.63 3.70	34.0 35.4	96.0 94.0	3.75 3.80	6.7 6.1	1650 1850	51.7 52.9	35.5 38.7	0.69 0.73	2.04 2.13	58.7 60.2	25.4 24.8	- -
50	10.0	2.7	6.2	1650 1850	48.8 50.4	3.61 3.66	36.5 37.9	97.4 95.2	3.97 4.03	6.8 6.3	1650 1850	52.7 54.2	35.1 38.9	0.67 0.72	2.31 1.00	60.6 57.6	22.9 28.1	2.3 2.4
	13.0	4.5	10.4	1650 1850	50.6 52.1	3.61 3.66	38.2 39.6	98.4 96.1	4.10 4.17	7.0 6.4	1650 1850	53.2 54.7	35.3 39.1	0.66 0.71	2.25 2.29	60.9 62.5	23.7 23.9	2.1 2.3
	16.0	6.4	14.8	1650 1850	52.9 54.5	3.70 3.74	40.3 41.7	99.7 97.3	4.20 4.27	7.2 6.6	1650 1850	54.1 55.6	36.2 40.1	0.67 0.72	2.23 2.27	61.7 63.3	24.3 24.5	2.0 2.2
60	10.0	2.6	6.0	1650 1850	54.7 56.1	3.72 3.75	42.0 43.3	100.7 98.1	4.30 4.38	7.5 6.9	1650 1850	51.4 52.8	34.1 37.7	0.66 0.71	2.62 2.67	60.3 61.9	19.6 19.8	3.2 3.4
	13.0	4.3	10.0	1650 1850	56.9 58.2	3.72 3.74	44.2 45.5	101.9 99.1	4.49 4.56	7.7 7.1	1650 1850	51.8 53.3	34.3 37.9	0.66 0.71	2.55 2.60	60.5 62.2	20.3 20.5	3.0 3.2
	16.0	6.2	14.3	1650 1850	58.9 60.2	3.80 3.82	45.9 47.2	103.0 100.1	4.54 4.62	7.9 7.3	1650 1850	52.7 54.2	35.1 38.9	0.67 0.72	2.53 2.58	61.3 63.0	20.8 21.0	2.8 3.1
70	10.0	2.5	5.8	1650 1850	60.5 63.2	3.84 3.85	47.4 50.1	103.9 101.6	4.62 4.81	8.3 7.7	1650 1850	50.0 52.4	33.0 37.8	0.66 0.72	2.94 3.05	60.0 61.8	17.0 17.2	4.4 4.6
	13.0	4.2	9.7	1650 1850	63.1 64.3	3.82 3.82	50.1 51.3	105.4 102.2	4.84 4.93	8.5 7.9	1650 1850	50.4 51.8	33.2 36.8	0.66 0.71	2.86 2.92	60.2 62.6	17.6 17.8	4.1 4.4
	16.0	6.0	13.9	1650 1850	64.8 65.9	3.91 3.90	51.4 52.6	106.4 103.0	4.86 4.95	8.8 8.1	1650 1850	51.3 52.7	34.1 37.7	0.66 0.72	2.84 2.89	61.0 62.8	18.1 18.2	3.8 4.2
80	10.0	2.4	5.6	1650 1850	66.4 67.3	3.90 3.88	53.1 54.1	107.3 103.7	4.99 5.09	9.2 8.5	1650 1850	47.6 48.9	31.8 35.2	0.67 0.72	3.35 3.42	59.0 60.6	14.2 14.3	6.1 5.9
	13.0	4.1	9.4	1650 1850	69.6 70.4	3.87 3.85	56.4 57.3	109.1 105.2	5.26 5.37	9.5 8.8	1650 1850	48.0 49.3	32.0 35.4	0.67 0.72	3.27 3.33	59.1 60.7	14.7 14.8	5.2 5.6
	16.0	5.8	13.4	1650 1850	70.6 71.3	3.96 3.92	57.1 57.9	109.6 105.7	5.23 5.33	9.8 9.1	1650 1850	48.8 50.2	32.8 36.4	0.67 0.72	3.24 3.30	59.8 61.4	15.1 15.2	4.8 5.8
90	10.0	2.3	5.4	1650 1850	72.3 72.9	3.96 3.91	58.8 59.5	110.6 106.5	5.35 5.46	10.3 9.5	1650 1850	45.2 46.4	30.7 33.9	0.68 0.73	3.77 3.84	58.0 59.5	12.0 12.1	8.0 8.5
	13.0	3.9	9.0	1650 1850	76.0 76.5	3.93 3.87	62.6 63.3	112.7 108.3	5.68 5.79	10.6 9.8	1650 1850	45.6 46.8	30.8 34.1	0.68 0.73	3.67 3.74	58.1 59.6	12.4 12.5	7.5 8.1
	16.0	5.6	12.9	1650 1850	76.4 76.7	4.00 3.94	62.7 63.3	112.8 108.4	5.59 5.71	11.0 10.2	1650 1850	50.2 47.6	35.9 35.0	0.72 0.74	3.55 3.71	62.3 60.3	14.1 12.8	6.9 7.7
100	10.0	2.2	5.2	Operation not recommended							Operation not recommended							
	13.0	3.8	8.7	Operation not recommended							Operation not recommended							
	16.0	5.4	12.5	1650 1850	44.7 45.9	3.2 3.6	32.2 35.6	108.3 105.9	5.46 5.56	10.2 9.5	1650 1850	45.4 46.7	33.0 36.6	0.73 0.78	4.11 4.19	59.4 60.9	11.0 11.1	9.0 10.0
110	10.0	2.2	5.0	Operation not recommended							Operation not recommended							
	13.0	3.6	8.4	Operation not recommended							Operation not recommended							
	16.0	5.2	12.0	1650 1850	43.7 45.0	3.36 3.72	33.6 37.2	107.7 103.3	5.26 5.37	9.5 8.8	1650 1850	44.5 45.7	34.4 38.1	0.77 0.83	4.62 4.67	59.5 61.6	9.5 9.8	12.7 13.1
120	10.0	2.1	4.8	Operation not recommended							Operation not recommended							
	13.0	3.5	8.1	Operation not recommended							Operation not recommended							
	16.0	5.0	11.5	1650 1850	39.6 40.3	3.10 3.37	31.0 33.7	107.8 103.3	5.60 5.78	11.0 10.2	1650 1850	39.9 40.8	31.0 33.7	0.78 0.83	5.60 5.78	59.4 60.5	6.8 7.1	15.7 16.7

Performance capacities shown in thousands of Btuh.

## Service Parts List

Parts List		Dual Capacity Units				
		024	036	048	060	072
Compressor	Compressor 208-230/60/1	34P749-01	34P751-01	34P753-01	34P755-01	34P756-01
	Run Capacitor 208-230/60/1	16P008D18CK	16P008D21CK	16P008D31CK	16P008D32CK	16P008D34CK
	Power Harness	11P781-01	11P781-01	11P781-01	11P781-01	11P781-01
	Solenoid Harness	11P782-02	11P782-02	11P782-02	11P782-02	11P782-02
5 Speed ECM Motor & Blower	5 Speed ECM Motor 208-230/60/1	14S590-01	14S590-02	14S591-01	14S591-02	14S591-03
	5 Speed ECM Blower Housing	53P500B01	53P500B01	53P501B01	53P501B01	53P501B01
Air Filters	1" Air Filters (Horizontal Model) and Second Filter If Needed	59B503B07	59B503B23	59B503B08	59B503B08	59B503B02
		n/a	n/a	n/a	n/a	59B503B24
	1" Air Filters (Vertical Model)	59P503B12	59P509B27	59P503B28	59P503B28	59P503B21
Refrigeration Components	Air Coil (Vertical Model)	61P721-41	61P705-41	61P706-41	61P706-41	61P715-41
	Air Coil (Horizontal Model)	61P720-41	61P707-41	61P709-41	61P709-41	61P710-41
	Coax	62I592-01	62I594-01	62I568-01	62I583-01	62I543A01
	TXV	33P619-30	33P619-31	33P619-32	33P619-33	33P619-34
	Reversing Valve	33P506-05	33P506-05	33P526-05	33P526-05	33P526-05
	Discharge Muffler	36P503B02	36P503B02	36P503B02	36P503B02	36P503B02
	Filter Dryer	36P500B01	36P500B01	36P500B01	36P500B02	36P500B02
Hot Water Generator	Hot Water Generator	62P516-05	62P516-05	62P516-03	62P516-03	62P516-03
	Hot Water Generator Pump	24P501A01	24P501A01	24P501A01	24P501A01	24P501A01
Electrical	Contactator	13P521-01	13P521-01	13P521-01	13P521-01	13P521-01
	Transformer 208-230/60/1	15P501B01	15P501B01	15P501B01	15P501B01	15P501B01
	3 Pole Power Block	12P503-06	12P503-06	12P503-06	12P503-06	12P503-06
	2 Pole Screw Term. Block	12P500A01	12P500A01	12P500A01	12P500A01	12P500A01
	ABC Board	17X553-48	17X553-48	17X553-48	17X553-48	17X553-48
	ASB Board	n/a	n/a	n/a	n/a	17P599-01
	ASB Sensor	n/a	n/a	n/a	n/a	19P688-01
	Keystone Category 5 Coupler (AID Port)	12P553-01	12P553-01	12P553-01	12P553-01	12P553-01
	Category 5 cable (AID Port to ABC)	11P846-01	11P846-01	11P846-01	11P846-01	11P846-01
	Rocker Switch - HWG ON/OFF	13P607A01	13P607A01	13P607A01	13P607A01	13P607A01
	Pump Circuit Breaker - 5 amp, 250v	19P583-01	19P583-01	19P583-01	19P583-01	19P583-01
Sensors & Safeties	Thermistor, Low Water Coil Limit (FPI)	FP1RK01	FP1RK01	FP1RK01	FP1RK01	FP1RK01
	HW Thermo-switch SPNC 130°F	13P073B05	13P073B05	13P073B05	13P073B05	13P073B05
	High Pressure Switch	SKHPE600	SKHPE600	SKHPE600	SKHPE600	SKHPE600
	Low Pressure Switch	SKLPE40	SKLPE40	SKLPE40	SKLPE40	SKLPE40

Part numbers subject to change

6/21/24

## Decommissioning

Before carrying out this procedure, it is essential that the technician is completely familiar with the equipment and all its detail. It is recommended good practice that all refrigerants are recovered safely. Prior to the task being carried out, an oil and refrigerant sample shall be taken in case analysis is required prior to re-use of recovered refrigerant. It is essential that electrical power is available before the task is commenced.

1. Become familiar with the equipment and its operation.
2. Isolate system electrically.
3. Before attempting the procedure, ensure that:
  - mechanical handling equipment is available, if required, for handling refrigerant cylinders;
  - all personal protective equipment is available and being used correctly;
  - the recovery process is supervised at all times by a competent person;
  - recovery equipment and cylinders conform to the appropriate standards.
4. Pump down refrigerant system, if possible.
5. If a vacuum is not possible, make a manifold so that refrigerant can be removed from various parts of the system.
6. Make sure that cylinder is situated on the scales before recovery takes place.
7. Start the recovery machine and operate in accordance with instructions.
8. Do not overfill cylinders (no more than 80 % volume liquid charge).
9. Do not exceed the maximum working pressure of the cylinder, even temporarily.
10. When the cylinders have been filled correctly and the process completed, make sure that the cylinders and the equipment are removed from site promptly and all isolation valves on the equipment are closed off.
11. Recovered refrigerant shall not be charged into another REFRIGERATING SYSTEM unless it has been cleaned and checked

## Decommissioning - Unit Labeling Requirements

Equipment shall be labelled stating that it has been de-commissioned and emptied of refrigerant. The label shall be dated and signed. For appliances containing FLAMMABLE REFRIGERANTS, ensure that there are labels on the equipment stating the equipment contains FLAMMABLE REFRIGERANT.

## Refrigerant Recovery

When removing refrigerant from a system, either for servicing or decommissioning, it is recommended good practice that all refrigerants are removed safely.

When transferring refrigerant into cylinders, ensure that only appropriate refrigerant recovery cylinders are employed. Ensure that the correct number of cylinders for holding the total system charge is available. All cylinders to be used are designated for the recovered refrigerant and labelled for that refrigerant (i.e. special cylinders for the recovery of refrigerant). Cylinders shall be complete with pressure-relief valve and associated shut-off valves in good working order. Empty recovery cylinders are evacuated and, if possible, cooled before recovery occurs.

The recovery equipment shall be in good working order with a set of instructions concerning the equipment that is at hand and shall be suitable for the recovery of the flammable refrigerant. If in doubt, the manufacturer should be consulted. In addition, a set of calibrated weighing scales shall be available and in good working order. Hoses shall be complete with leak-free disconnect couplings and in good condition.

The recovered refrigerant shall be processed according to local legislation in the correct recovery cylinder, and the relevant waste transfer note arranged. Do not mix refrigerants in recovery units and especially not in cylinders.

If compressors or compressor oils are to be removed, ensure that they have been evacuated to an acceptable level to make certain that flammable refrigerant does not remain within the lubricant. The compressor body shall not be heated by an open flame or other ignition sources to accelerate this process. When oil is drained from a system, it shall be carried out safely.

## Refrigerant Removal and Evacuation

When breaking into the refrigerant circuit to make repairs – or for any other purpose conventional procedures shall be used. However, for flammable refrigerants it is important that best practice be followed, since flammability is a consideration.

The following procedure shall be adhered to:

- safely remove refrigerant following local and national regulations;
- evacuate;
- purge the circuit with inert gas (optional for A2L);
- evacuate (optional for A2L);
- continuously flush or purge with inert gas when using flame to open circuit; and
- open the circuit.

The refrigerant charge shall be recovered into the correct recovery cylinders if venting is not allowed by local and national codes. For appliances containing flammable refrigerants, the system shall be purged with oxygen-free nitrogen to render the appliance safe for flammable refrigerants.

This process might need to be repeated several times. Compressed air or oxygen shall not be used for purging refrigerant systems. For appliances containing flammable refrigerants, refrigerants purging shall be achieved by breaking the vacuum in the system with oxygen-free nitrogen and continuing to fill until the working pressure is achieved, then venting to atmosphere, and finally pulling down to a vacuum (optional for A2L). This process shall be repeated until no refrigerant is within the system (optional for A2L). When the final oxygen-free nitrogen charge is used, the system shall be vented down to atmospheric pressure to enable work to take place. The outlet for the vacuum pump shall not be close to any potential ignition sources, and ventilation shall be available.

## Charging procedures

In addition to conventional charging procedures, the following requirements shall be followed.

- Ensure that contamination of different refrigerants does not occur when using charging equipment.
- Hoses or lines shall be as short as possible to minimise the amount of refrigerant contained in them.
- Cylinders shall be kept in an appropriate position according to the instructions.
- Ensure that the REFRIGERATING SYSTEM is earthed prior to charging the system with refrigerant.
- Label the system when charging is complete (if not already).
- Extreme care shall be taken not to overfill the REFRIGERATING SYSTEM.

Prior to recharging the system, it shall be pressure-tested with the appropriate purging gas. The system shall be leak-tested on completion of charging but prior to commissioning. A follow up leak test shall be carried out prior to leaving the site.

# Revision Guide

<b>Pages:</b>	<b>Description:</b>	<b>Date:</b>	<b>By:</b>
All	Document Creation	14 March 2024	SW
5	Update Maximum Altitude rating	25 July 2024	SW
9	Update Physical Data Factory Charge	25 July 2024	SW
29	Add A2L Electrical Warnings	17 Sept 2024	SW
20	Update Pressure Drop	19 Dec 2024	SW
66	Update 048 Performance Data	19 Dec 2024	SW



Product: **LX Series**  
Type: Dual Compressor Packaged Heat Pump  
Size: 2-6 Ton

Document Type: Installation Guide  
Part Number: OMW3-0019Y  
Release Date: 12/2024



©2024 The manufacturer has a policy of continual product research and development and reserves the right to change design and specifications without notice.

York and Affinity are registered trademarks of Johnson Controls, Inc., and are used with permission.