



M-SERIES & P-SERIES

Pocket Reference Guide

mitsubishipro.com

MAKE COMFORT *Personal*[™]

Pre-visit Checklist

✓	Verify appointment
✓	Call 30 minutes before you arrive
✓	Verify equipment in stock at distributor
✓	Credit application/financing options
✓	Local rebate information
✓	Bring this booklet along so you have product information and the contact phone numbers below handy

Customer Care: **800-433-4822**

www.mitsubishipro.com

Advanced Technology.

Superior Comfort.

Split-zoning is the most popular type of air-conditioning technology in the world. Mitsubishi Electric takes split-zoning to a new level—our cooling and heating systems deliver year-round personal comfort even in the harshest of climates.

Mitsubishi Electric single- and multi-split systems also feature:

- ▶ Exceptional cooling and heating performance.
- ▶ Automatic cool/heat changeover.
- ▶ Maximum energy efficiency with higher SEER and HSPF ratings.
- ▶ Easy installation.
- ▶ Environmentally friendly R410A refrigerant.
- ▶ Convenient temperature, fan, and airflow control.
- ▶ Advanced filtration to help provide high air quality.
- ▶ Whisper-quiet operation.

M-Series components are up to 83% recyclable

M-Series was green before green was cool.



ENERGY STAR®

Mitsubishi Electric systems are now more environmentally friendly than ever!

Use them to earn many available state, municipal, and utility rebates.

M-Series Qualifying Models*

MUY-GE09NA & MSY-GE09NA-9
MUY-GE09NA2 & MSY-GE09NA-9
MUY-GE12NA & MSY-GE12NA-9
MUY-GE12NA2 & MSY-GE12NA -9
MUY-GE15NA-1 & MSY-GE15NA-9
MUY-GE15NA2 & MSY-GE15NA-9
MUY-GE24NA & MSY-GE24NA
MUZ-FE09NA-1 & MSZ-FE09NA-8
MUZ-FE12NA1 & MSZ-FE12NA-8
MUZ-FE18NA & MSZ-FE18NA
MUZ-FH09NA & MSZ-FH09NA
MUZ-FH12NA & MSZ-FH12NA
MUZ-FH15NA & MSZ-FH15NA
MUZ-FH18NA & MSZ-FH18NA
MUZ-GE09NA2 & MSZ-GE09NA-9
MUZ-GE12NA2 & MSZ-GE12NA-9
MUZ-GE15NA2 & MSZ-GE15NA-9
MUZ-GE15NA-1 & MSZ-GE15NA-9
MUZ-GE09NA & MSZ-GE09NA-9
MUZ-GE12NA & MSZ-GE12NA-9
MUZ-GE24NA & MSZ-GE24NA
SUZ-KA09NA & SEZ-KD09NA4
SUZ-KA12NA & SEZ-KD12NA4
SUZ-KA15NA & SEZ-KD15NA4
SUZ-KA18NA & SEZ-KD18NA4
SUZ-KA09NA & SLZ-KA09NA4
SUZ-KA12NA & SLZ-KA12NA4
MXZ-2B20NA-1 w/ Non-Ducted Indoor Units

M-Series Qualifying Models*

MXZ-2B20NA-1 w/ Specific (reference AHRI Directory)
MXZ-2C20NAHZ w/ Non-Ducted Indoor Units
MXZ-2C20NAHZ w/ Mixed Ducted and Non-Ducted Indoor Units
MXZ-3C24NA w/ Non-Ducted Indoor Units
MXZ-3C24NA w/ Specific (reference AHRI Directory)
MXZ-3C24NA w/ Non-Ducted Indoor Units
MXZ-3C24NAHZ w/ Non-Ducted Indoor Units
MXZ-3C24NA w/ Mixed Non-Ducted and Ducted Indoor Units
MXZ-3C30NAHZ w/ Non-Ducted Indoor Units
MXZ-4C36NAHZ w/ Non-Ducted Indoor Units
MXZ-4C36NAHZ w/ Mixed Non-Ducted and Ducted Indoor Units
MXZ-5C42NAHZ w/ Non-Ducted Indoor Units
MXZ-5C42NAHZ w/ Mixed Non-Ducted and Ducted Indoor Units
MXZ-8C48NA w/ Non-Ducted Indoor Units
MXZ-8C48NAHZ w/ Non-Ducted Indoor Units

P-Series Qualifying Models*

PUZ-HA30NHA4 & PCA-A30KA6
PUZ-HA30NHA4 & PEAD-A30AA5
PUZ-HA30NHA4 & PKA-A30KA6
PUZ-HA30NHA4 & PLA-A30BA6
PUZ-HA30NHA4 & PVA-A30AA4
PUZ-HA36NHA4 & PCA-A36KA6
PUZ-HA36NHA4 & (x2) PEA-A18AA6
PUZ-HA36NHA4 & PEAD-A36AA5
PUZ-HA36NHA4 & PKA-A36KA6
PUZ-HA36NHA4 & PLA-A36BA6
PUZ-HA36NHA4 & PVA-A36AA44

For tax credit details and forms
visit www.mitsubishicomfort.com/taxcredit

For details on state and utility rebates
visit www.dsireusa.org

*ENERGY STAR certified model as of print time

How to Read a Model Number

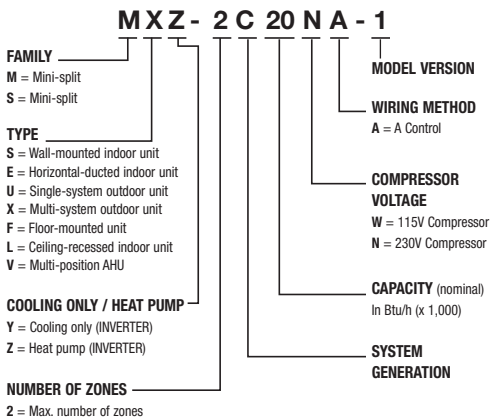

M-Series (9,000 - 48,000 Btu/h)

1. Designed for residential applications.
2. User-friendly zoned cooling and heating solutions for single- or multi-room applications or the whole home.
3. Hyper-Heating INVERTER™ (H2i®) outdoor units can provide high heating performance at lower ambient temperatures.
4. Many ENERGY STAR® certified models.

How to Read a Model Number

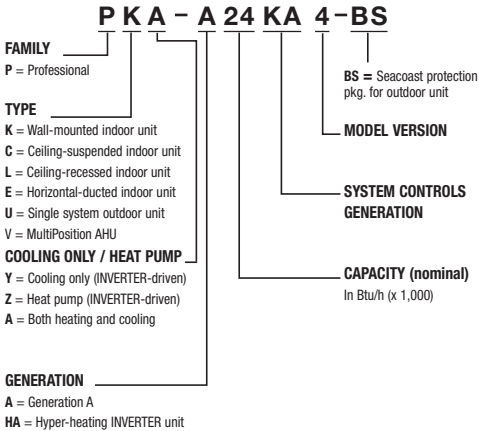

1. For light commercial, industrial, or institutional installations- ideal for applications requiring year-round, low ambient cooling such as computer, elevator and equipment rooms.
2. Hyper-Heating INVERTER™ (H2i®) outdoor units can provide superior heating performance at lower ambient temperatures.
3. Long lineset lengths.
4. Outside air intake on PLA, PCA PEA/D and PVA models.

M-Series Models

Our standard line is now greener than ever!

GE Models

- ▶ Eight ENERGY STAR® models.
- ▶ "Smart Set" programming button with SETBACK down to 50° F in heating (9,000 - 18,000 only).
- ▶ Washable 10-year catechin filter and anti-allergy enzyme filter.
- ▶ Cooling-only and heat pump models.
- ▶ Five fan speeds plus AUTO (Select Models).
- ▶ As quiet as 19 dB(A).



(9,000 - 22,500 Btu/h)

*See pages 12 and 16
for more information.*

D Models

(30,700 - 34,600 Btu/h)

- ▶ Wide vane mode for precise directional airflow (also available on MSY/Z-GE24NA).
- ▶ Powerful mode for quick 15 minute heating/cooling boost (also available on MSY/Z-GE24NA).
- ▶ Cooling-only and heat pump models.



With the WIDE VANE or SWING mode, available on the MSY(Z)-GE24/D30/36NA there is an option for seven horizontal airflow directions that provide 150° of airflow for greater conditioned air circulation.

High-efficiency, Hyper-heating systems

FE & FH Models

- ▶ 30.5 - 22.0 SEER, 13.5 - 12.0 HSPF, INVERTER-driven compressor.
- ▶ Quiet operation as low as 20 dB(A).
- ▶ Hyper-heating performance down to minus 13° F outdoor ambient.
- ▶ 100% heating capacity at 5° F outdoor ambient.
- ▶ Quiet operation as low as 20 dB(A).
- ▶ Triple-action filtration.
 - Nano-platinum filter.
 - Electrostatic anti-allergen enzyme filter.
 - Deodorizing filter.
- ▶ Energy saving mode.
- ▶ Double-vane air delivery for enhanced circulation.
 - Option to set each vane separately.
 - Indirect or direct setting option.
 - Natural flow setting that creates air movement like a natural breeze.
- ▶ i-see Sensor™ 3D.
 - Infrared human sensing technologies to measure location of human heat signatures.
 - Senses floor temperature in order to deliver conditioned air to those areas that need it using double-vane airflow and motorized vertical vanes.
- ▶ NEW multi-function hand-held wireless controller or wall-mounted wireless controller available with smart phone control capabilities.



(9,000 - 18,000 Btu/h)

See page 14 for more information.

MFZ Models

- ▶ Ideal for low-wall mounted applications.
- ▶ Bi-directional airflow (top and bottom discharge).
- ▶ "Smart Set" programming button with SETBACK down to 50° F in heating.
- ▶ Washable, 10-year catechin filter and anti-allergy enzyme filter.
- ▶ For use with MXZ multi-zone outdoor units only.



(9,000 - 18,000 Btu/h)

See page 19 for more information.

M-Series Models



SEZ Models

- ▶ Small compact design (7-7/8" height). (8,100 – 17,200 Btu/h)
- ▶ Adjustable static pressure.
- ▶ Built-in condensate lift mechanism (22-1/2" lift).
- ▶ Rear return or bottom return (with optional accessory).
- ▶ Low operating sound pressure levels; as low as 23 dB(A).
- ▶ All four ENERGY STAR® certified models.

See pages 20-21 for more information.

SLZ Models

- ▶ Fits in 2x2 suspended ceiling grid.
- ▶ 4-way airflow.
- ▶ Built-in condensate lift mechanism (19-11/16" lift).
- ▶ Catechin deodorizing filter.
- ▶ Two ENERGY STAR® rated models.
- ▶ Outside air intake.



(8,400 – 15,000 Btu/h)

MVZ Models

- ▶ Performance: One inch foam R4.2, fiberglass-free insulation reduces condensation and boosts efficiency.
- ▶ Quality: durable, powder coated cabinet.
- ▶ Serviceability: easily removable fan provides access for coil cleaning.
- ▶ Flexibility: true multi-position, requiring no additional kits for downflow configuration.
- ▶ Installation: quality construction with disassembly in mind to make fitting through tight access points simple.
- ▶ Comfort: DC motor ensures quiet and efficient operation year round.
- ▶ Low Impact: Fully RoHS compliant to reduce carbon footprint.
- ▶ Air Quality: Positively pressurized cabinet and tested air leakage less than 1%.
- ▶ For use with MXZ Multi-zone outdoor units only.



(12,000 - 40,000 Btu/h)

See pages 18-19 for more information.

MXZ Multi-zone Heat Pumps

2:1, 3:1, 4:1, 5:1, and 8:1 Zoned Solutions

(20,000-48,000 Btu/h)

- ▶ Many combinations have received the ENERGY STAR® certification.
- ▶ Precise, individual room comfort control.
- ▶ Multiple indoor air handler options (non-ducted and ducted).
- ▶ Minimum of two indoor units must be installed.



STANDARD:	H2i:
MXZ-2B20NA-1	MXZ-2C20NAHZ
MXZ-3C24NA	MXZ-3C24NAHZ
MXZ-3C30NA	MXZ-3C30NAHZ
MXZ-4C36NA	MXZ-4C36NAHZ
MXZ-5C42NA	MXZ-5C42NAHZ
MXZ-8C48NA	MXZ-8C48NAHZ

See pages 18-19 for more information.

Multi-zone Heat Pump Lineup

Indoor Units:



MSZ-FH09 -18NA
MSZ-GE06-24NA

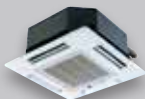

SLZ-KA09-15NA
PLA-A12-36BA



MFZ-KA09-18NA
(for use with MXZ only)



SEZ-KD09-18NA4
PEAD-A24-36AA5



MVZ-A12-36AA4
(for use with MXZ only)

DIAMOND COMFORT SYSTEM™



Outdoor Unit

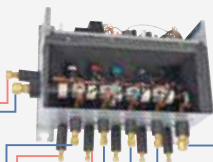

HORIZONTAL-DUCTED
INDOOR UNITS



FLOOR-MOUNTED
INDOOR UNITS

*Illustration purposes only. Refer to compatibility chart for combination allowances.

Multi-zone Systems*



WALL-MOUNTED
INDOOR UNITS



MULTI-POSITION DUCTED
AIR HANDLER



CEILING-RECESSED
INDOOR UNITS

M-Series Cooling-only Systems

MSY

Model Specifications

(air conditioners)

Indoor Model #	MSY-GE09NA-9	MSY-GE12NA-9	
Outdoor Model #	MUY-GE09NA2	MUY-GE12NA2	
Rated Cooling Capacity (Btu/h)	9,000	12,000	
Cooling Capacity Range (Btu/h)	3,800-12,200	3,800-13,600	
SEER	23.2	22.7	
Lineset Size (Liquid x Gas)	1/4" x 3/8"	1/4" x 3/8"	
Lineset Length/Height Max. Separation	65'/40'	65'/40'	
Breaker Size	15 AMP	15 AMP	

Test conditions are based on AHRI 210/240.



MUY-GE15NA-2

MSY-GE15NA-9

	MSY-GE15NA-9	MSY-GE18NA-9	MSY-GE24NA	MSY-D30NA-8	MSY-D36NA-8
	MUY-GE15NA2	MUY-GE18NA-1	MUY-GE24NA	MUY-D30NA-1	MUY-D36NA-1
	14,000	17,200	22,500	30,700	34,600
	3,100-18,200	3,700-18,700	8,200-31,400	9,800-30,700	9,800-34,600
	21.6	19.2	19	16	15.1
	1/4" x 1/2"	1/4" x 1/2"	3/8" x 5/8"	3/8" x 5/8"	3/8" x 5/8"
	65'/40'	100'/50'	100'/50'	100'/50'	100'/50'
	15 AMP	15 AMP	20 AMP	25 AMP	25 AMP

M-Series units are pre-charged for up to a 25' line set.

M-Series Heat Pump Systems

MSZ/MUZ H2i® Model Specifications

(heat pumps)



Indoor Model #	MSZ-FH09NA	MSZ-FH12NA	
Outdoor Model #	MUZ-FH09NA	MUZ-FH12NA	
Rated Cooling Capacity (Btu/h)	9,000	12,000	
Cooling Capacity Range (Btu/h)	1,700-12,000	2,500-13,600	
Heating Capacity Range at 47°F (Btu/h)	1,600 - 18,000	3,700 - 21,000	
Max. Heating Capacity at 17°F (Btu/h)	12,200	13,600	
Max. Heating Capacity at 5°F (Btu/h)	10,900	13,600	
SEER/HSPF	30.5/13.5	26.1/12.5	
Lineset Size (Liquid x Gas)	1/4" x 3/8"		
Lineset Length/Height Max. Separation	65'/40'	65'/40'	
Breaker Size	15 AMP	15 AMP	

Test conditions are based on AHRI 210/240.



MSZ-FH09NA



MUZ-FH09NA



	MSZ-FH15NA	MSZ-FH18NA
	MUZ-FH15NA	MUZ-FH18NA
	15,000	17,200
	6,450 - 19,000	6,450 - 21,000
	5,150 - 24,000	5,150 - 30,000
	18,000	20,300
	18,000	20,300
	22.0/12.0	21.0/12.0
	1/4" x 1/2"	
	100'/50'	100'/50'
	20 AMP	20 AMP

M-Series Heat Pump Systems

MSZ/MUZ

Model Specifications

(heat pumps)

Indoor Model #	MSZ-GE09NA-9	MSZ-GE12NA-9	MSZ-GE15NA-9	
Outdoor Model #	MUZ-GE09NA2	MUZ-GE12NA2	MUZ-GE15NA2	
Rated Cooling Capacity (Btu/h)	9,000	12,000	14,000	
Cooling Capacity Range (Btu/h)	3,800-12,200	3,800-13,600	3,100-18,200	
Heating Capacity Range at 47° F (Btu/h)	4,500-14,100	5,500-18,100	4,800-20,900	
Max. Heating Capacity at 17° F (Btu/h)	8,700	11,200	15,900	
Max. Heating Capacity at 5° F (Btu/h)	7,061	9,194	13,022	
SEER/HSPF	23.2/11	22.7/11.4	21.6/11.2	
Lineset Size (Liquid x Gas)	1/4" x 3/8"	1/4" x 3/8"	1/4" x 1/2"	
Lineset Length/ Height Max. Separation	65'/40'	65'/40'	65'/40'	
Breaker Size	15 AMP	15 AMP	15 AMP	

Test conditions are based on AHRI 210/240.



MSZ-GE09NA-9



MUZ-GE09NA2

	MSZ-GE18NA-9	MSZ-GE24NA	MSZ-D30NA-8	MSZ-D36NA-8
	MUZ-GE18NA-1	MUZ-GE24NA	MUZ-D30NA-1	MUZ-D36NA-1
	17,200	22,500	30,700	33,200
	3,700-18,700	8,200-31,400	9,800-30,700	9,800-33,200
	3,500-25,200	7,500-36,900	8,700-34,000	8,700-36,000
	17,200	24,600	20,800	22,800
	13,562	21,160	16,305	19,090
	19.2/10	19/10	14.5/8.2	14.5/8.2
	1/4" x 1/2"	3/8" x 5/8"	3/8" x 5/8"	3/8" x 5/8"
	100'/50'	100'/50'	100'/50'	100'/50'
	15 AMP	20 AMP	25 AMP	25 AMP

MSZ-GE24NA and MSZ-FH18NA precharged to 33' line set

M-Series Heat Pump Systems

MVZ and MFZ for MXZ-C

Model Specifications

(heat pumps)



Indoor Model #	MFZ-KA09NA	MFZ-KA12NA	MFZ-KA18NA	
Outdoor Unit	MXZ-C Standard and MXZ-C H2i®			
Rated Cooling Capacity (Btu/h)	9,000	12,000	18,000	
Rated Heating Capacity at 47° F (Btu/h)	10,900	14,400	21,600	
Airflow at Cooling/ Heating (SH-H-M-L) (H-M-L) (CFM)	169-205-251-314 163-197-241-303	177-215-261-321 170-207-252-309	251-279-325-394 241-269-313-379	
ESP (In. W.G.)	-	-	-	
Sound at Cooling/ Heating (SH-H-M-L) (H-M-L) (dB<A>)	40-35-30-25 40-35-30-25	41-36-31-26 41-36-31-26	46-42-38-35 47-42-38-35	
Lineset Size (Liquid x Gas)	3/8" x 1/4"	3/8" x 1/4"	1/2" x 1/4"	
Breaker Size	25 AMP	25 AMP	25 AMP	

Test conditions are based on AHRI 210/240.



MVZ-A12AA4

	MVZ-A12AA4	MVZ-A18AA4	MVZ-A24AA4	MVZ-A30AA4	MVZ-A36AA4
	MXZ-C Standard and MXZ-C H2i®				
	12,000	18,000	24,000	30,000	36,000
	13,500	20,000	27,000	34,000	40,000
	400-340-280 400-340-280	585-497-410 585-497-410	735-625-515 735-625-515	875-744-613 875-744-613	1095-931-767 1095-931-767
	0.30-0.50-0.80				
	35-31-27 35-31-27	36-32-36 36-32-36	38-34-30 38-34-30	40-36-21 40-36-21	43-39-35 43-39-35
	1/4" x 3/8"	1/4" x 3/8"	1/4" x 1/2"	1/4" x 1/2"	3/8" x 5/8"
	15 AMP	15 AMP	15 AMP	15 AMP	20 AMP

SEZ/SLZ System Specifications

(heat pumps)



SUZ-KA15NA



SEZ-KD15NA4

Indoor Model #	SEZ-KD09NA4	SEZ-KD12NA4	SEZ-KD15NA4	
Outdoor Model #	SUZ-KA09NA	SUZ-KA12NA	SUZ-KA15NA	
Rated Cooling Capacity (Btu/h)	8,100	11,500	14,100	
Cooling Capacity Range (Btu/h)	3,800-10,900	3,800-13,300	3,800-17,000	
Heating Capacity Range at 47° F (Btu/h)	4,800-14,100	4,800-16,400	4,800-21,100	
Heating Capacity at 17° F (Btu/h)	6,700	9,000	11,900	
SEER/HSPF	15/10	16/10	15.5/10	
Lineset Size (Liquid x Gas)	1/4" x 3/8"	1/4" x 3/8"	1/4" x 1/2"	
Lineset Length/Height Max. Separation	65'/40'	65'/40'	65'/40'	
Breaker Size (MOCP)	15 AMP	15 AMP	15 AMP	

Test conditions are based on AHRI 210/240.

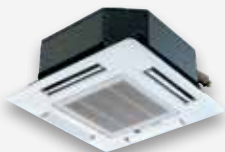

SLZ-KA15NA



All Controllers
Ordered separately



MHK1



	SEZ-KD18NA4	SLZ-KA09NA	SLZ-KA12NA	SLZ-KA15NA
	SUZ-KA18NA	SUZ-KA09NA	SUZ-KA12NA	SUZ-KA15NA
	17,200	8,400	11,100	15,000
	3,800-19,000	3,100-10,900	3,400-13,300	3,800-17,700
	4,800-24,900	3,100-14,100	3,100-17,100	3,100-22,200
	13,100	6,200	8,300	12,000
	17.5/10	15/9.6	15.4/9.6	16/9.6
	1/4" x 1/2"	1/4" x 3/8"	1/4" x 3/8"	1/4" x 1/2"
	100'/50'	65'/40'	65'/40'	65'/40'
	15 AMP	15 AMP	15 AMP	15 AMP

MXZ Series

MXZ-C

Model Specifications

(multi-zone heat pumps)

Outdoor Model #	MXZ-2B20NA-1	MXZ-3C24NA	
Rated Cooling Capacity (Btu/h)	18,000	22,000	
Cooling Capacity Range (Btu/h)	7,800-20,000	12,600-25,500	
Heating Capacity Range at 47° F (Btu/h)	8,500-25,500	11,400-30,600	
Heating Capacity at 17° F (Btu/h)	12,500	14,000	
Individual/Combined Max. Lineset Length	82'/164'	82'/230'	
Max. Vertical Separation	49*/33'	49*/49'	
Breaker Size	20 AMP	20 AMP	
SEER/HSPF non-ducted	18.00/8.90	20.00/9.80	
SEER/HSPF mixed	16.75/8.70	18.00/9.50	
SEER/HSPF ducted	15.50/8.50	16.00/9.20	

Test conditions are based on AHRI 210/240.

See page 3 for ENERGY STAR® certified combinations.
Refer to submittal document for combination performance.

** 131' applies when outdoor unit is installed below indoor unit.



MXZ-8C48NA



**BRANCH BOX
FOR INDOOR UNIT
CONNECTIONS**

Each MXZ-8C48NA requires at least one branch box with a maximum of two.

Two sizes are available:
3-branch (PAC-AKA30BC)
and 5-branch
(PAC-AKA50BC,
shown above).

	MXZ-3C30NA	MXZ-4C36NA	MXZ-5C42NA	MXZ-8C48NA
	28,400	35,400	40,800	48,000
	12,600-28,400	12,600-36,400	6,000-43,000	6,000-48000
	11,400-36,000	11,400-43,000	7,200 -53,600	7,200 -54,000
	16,000	22,200	24,400	36,600
	82'/230'	82'/230'	82'/230'	262'/492'
	49'*/49'	49'*/49'	49'*/49'	131'*/164'
	20 AMP	25 AMP	40 AMP	50 AMP
	19.00/10.60	19.20/11.00	19.70/10.30	18.90/11.40
	17.60/10.10	17.45/10.40	17.45/9.70	16.80/10.75
	16.20/9.60	16.00/9.80	15.20/9.10	14.70/10.10

SEE PAGE 26 FOR INDOOR UNIT CONNECTION CAPABILITIES.

See section 5 of installation manual for full details on MXZ-8C48NA refrigeration piping lengths.

MXZ Series

MXZ-C H2i[®]

Model Specifications

(*multi-zone heat pumps*)



Outdoor Model #	MXZ-2C20NAHZ	MXZ-3C24NAHZ	
Rated Cooling Capacity (Btu/h)	18,000	22,000	
Cooling Capacity Range (Btu/h)	6,000-20,000	6,000-23,600	
Heating Capacity Range at 47° F (Btu/h)	7,400-25,500	7,200-30,600	
Max. Heating Capacity at 17° F (Btu/h)	22,000	25,000	
Max. Heating Capacity at 5° F (Btu/h)	22,000	25,000	
Individual/Combined Max. Lineset Length	82'/164'	82'/230'	
Max. Vertical Separation	49'	49'	
Breaker Size	40 AMP	40 AMP	
SEER/HSPF non-ducted	17.00/9.80	19.00/10.00	
SEER/HSPF mixed	16.00/9.65	17.25/9.50	
SEER/HSPF ducted	15.00/9.50	15.50/9.00	

Test conditions are based on AHRI 210/240.

See page 3 for ENERGY STAR[®] certified combinations.
Refer to submittal document for combination performance.

** 131' applies when outdoor unit is installed below indoor unit.



MXZ-8C48NA



BRANCH BOX
FOR INDOOR UNIT
CONNECTIONS

Each MXZ-H2i® requires at least one branch box with a maximum of two.

Two sizes are available:
3-branch (PAC-AKA30BC) and
5-branch (PAC-AKA50BC,
shown above).



	MXZ-3C30NAHZ	MXZ-4C36NAHZ	MXZ-5C42NAHZ	MXZ-8C48NAHZ
	28,400	36,000	42,000	48,000
	6,000- 28,400	6,000- 36,000	6,000-4 2,000	6,000-4 8,000
	7,200-36,000	7,200-45,000	7,200-48,000	7,200-54,000
	28,600	45,000	48,000	54,000
	28,600	45,000	48,000	54,000
	82'/230'	262'/492'	262'/492'	262'/492'
	49**/49'	131'***/164'	131'***/164'	131'***/164'
	40 AMP	50 AMP	50 AMP	50 AMP
	18.00/11.00	19.10/11.30	19.00/11.00	18.90/11.00
	17.00/10.40	17.45/10.70	17.00/10.55	16.80/10.50
	16.00/9.80	15.80/10.70	15.00/10.10	14.70/10.00

SEE PAGE 28 FOR INDOOR UNIT CONNECTION CAPABILITIES.

See section 5 of installation manual for full details on refrigeration piping lengths.

MXZ-Series Port Adapters

PORT ADAPTER GUIDE

Available Indoor Units	Line Set Size
MSZ Wall-mounted	
MSZ-GE06NA-9	3/8" gas x 1/4" liquid
MSZ-GE09NA-9	3/8" gas x 1/4" liquid
MSZ-GE12NA-9	3/8" gas x 1/4" liquid
MSZ-GE15NA-9	1/2" gas x 1/4" liquid
MSZ-GE18NA-9	1/2" gas x 1/4" liquid
MSZ-GE24NA	5/8" gas x 3/8" liquid
MSZ-FE09NA-8	3/8" gas x 1/4" liquid
MSZ-FE12NA-8	3/8" gas x 1/4" liquid
MSZ-FE18NA	5/8" gas x 3/8" liquid
MSZ-FH09NA	3/8" gas x 1/4" liquid
MSZ-FH12NA	3/8" gas x 1/4" liquid
MSZ-FH15NA	1/2" gas x 1/4" liquid
MSZ-FH18NA	1/2" gas x 1/4" liquid
MFZ Floor-standing	
MFZ-KA09NA	3/8" gas x 1/4" liquid
MFZ-KA12NA	3/8" gas x 1/4" liquid
MFZ-KA18NA	1/2" gas x 1/4" liquid
MVZ Multi-position	
MVZ-A12AA4	1/2" gas x 1/4" liquid
MVZ-A18AA4	1/2" gas x 1/4" liquid
MVZ-A24AA4	5/8" gas x 3/8" liquid
MVZ-A30AA4	5/8" gas x 3/8" liquid
MVZ-A36AA4	5/8" gas x 3/8" liquid

Available Indoor Units	Line Set Size
PLA Ceiling-recessed	
PLA-A12BA6	1/2" gas x 1/4" liquid
PLA-A18BA6	1/2" gas x 1/4" liquid
PLA-A24BA6	5/8" gas x 3/8" liquid
PLA-A30BA6	5/8" gas x 3/8" liquid
PLA-A36BA6	5/8" gas x 3/8" liquid
PLA-A42BA6	5/8" gas x 3/8" liquid
PCA Ceiling-suspended	
PCA-A24KA6	5/8" gas x 3/8" liquid
SLZ Ceiling-recessed	
SLZ-KA09NA	3/8" gas x 1/4" liquid
SLZ-KA12NA	3/8" gas x 1/4" liquid
SLZ-KA15NA	1/2" gas x 1/4" liquid
SEZ/PEAD Horizontal-ducted	
SEZ-KD09NA4	3/8" gas x 1/4" liquid
SEZ-KD12NA4	3/8" gas x 1/4" liquid
SEZ-KD15NA4	1/2" gas x 1/4" liquid
SEZ-KD18NA4	1/2" gas x 1/4" liquid
PEAD-A24AA4	5/8" gas x 3/8" liquid
PEAD-A30AA4	5/8" gas x 3/8" liquid
PEAD-A36AA4	5/8" gas x 3/8" liquid

PORT ADAPTERS PART NUMBERS

MAC-A454JP-E	3/8" x 1/2"
MAC-A455JP-E	1/2" x 3/8"
MAC-A456JP-E	1/2" x 5/8"
PAC-SG76RJ-E	3/8" x 5/8"
PAC-493PL	1/4" x 3/8"

MXZ-Series Port Adapters

PORT ADAPTER GUIDE

Port	Gas	Liquid
MXZ-2B20NA-1		
A; B	3/8"	1/4"
MXZ-3C24NA		
A	1/2"	1/4"
B; C	3/8"	1/4"
MXZ-3C30NA		
A	1/2"	1/4"
B; C	3/8"	1/4"
MXZ-4C36NA		
A	1/2"	1/4"
B; C; D	3/8"	1/4"
MXZ-5C42NA		
A	1/2"	1/4"
B; C; D; E	3/8"	1/4"
MXZ-8C48NA		
A; B; C; D; E	5/8"	3/8"
MXZ-2C20NAHZ		
A; B	3/8"	1/4"
MXZ-3C24NAHZ		
A	1/2"	1/4"
B; C	3/8"	1/4"
MXZ-3C30NAHZ		
A	1/2"	1/4"
B; C	3/8"	1/4"
MXZ-4C36NAHZ		
A	1/2"	1/4"
B; C	3/8"	1/4"
MXZ-5C42NAHZ		
A	1/2"	1/4"
B; C; D	3/8"	1/4"
MXZ-8C48NAHZ		
A; B; C; D; E	5/8"	3/8"

The following MXZ units must utilize at least one branch box

MXZ-8C48NA
 MXZ-4C36NAHZ
 MXZ-5C42NAHZ
 MXZ-8C48NAHZ

Branch Boxes		
Port	Gas	Liquid
PAC-MKA30BC [3-Port]		
A; B; C	3/8"	1/4"
PAC-MKA50BC [5-Port]		
A; B; C; D	3/8"	1/4"
E	1/2"	1/4"

Notes for application:

- Check the lineset sizes for your indoor selected models.
- Select the branch box or boxes needed for your application.
- Compare indoor unit lineset sizes to branch box or outdoor unit port sizes.
- Connect 15K + indoor units to the larger 1/2" port on the PAC-AKA50BC branch box or outdoor unit.
- Adapt lineset size with appropriate port adapter from above list.
- When using the PLA-A24BA6, PEAD-A24AA5, PEAD-A30AA5, PEAD-A36AA5, MSZ-GE24NA two port adapters will be needed 1-MAC-A456JP-E (1/2" x 5/8") or 1-PAC-SG76RJ-E (3/8" x 5/8") and 1 - PAC-493PI (1/4" x 3/8").

M-Series Correction Factors

Cooling Capacity Correction Factors

Model	Refrigerant piping length (one way)			
	25 Ft (Std)	40 Ft	65 Ft	100 Ft
MUZ-GE09NA2	Capacity x 1.0	Capacity x 0.954	Capacity x 0.878	-
MUZ-GE12NA2				
MUZ-GE15NA2				
MUZ-GE18NA-1				
MUZ-GE24NA	Capacity x 1.0	Capacity x 0.954	Capacity x 0.878	Capacity x 0.771
MUZ-D30NA-1	Capacity x 1.0	Capacity x 0.95	Capacity x 0.878	Capacity x 0.713
MUZ-D36NA-1				
MUY-GE09NA2	Capacity x 1.0	Capacity x 0.954	Capacity x 0.878	-
MUY-GE12NA2				
MUY-GE15NA2				
MUY-GE18NA-1				
MUY-GE24NA	Capacity x 1.0	Capacity x 0.954	Capacity x 0.878	Capacity x 0.771
MUY-D30NA-1	Capacity x 1.0	Capacity x 0.95	Capacity x 0.878	Capacity x 0.713
MUY-D36NA-1				
MUZ-FE09NA-1	Capacity x 1.0	Capacity x 0.945	Capacity x 0.878	-
MUZ-FE12NA-1				
MUZ-FE18NA	Capacity x 1.0	Capacity x 0.945	Capacity x 0.878	Capacity x 0.771
MUZ-FH09NA	Capacity x 1.0	Capacity x 0.945	Capacity x 0.878	-
MUZ-FH12NA				
MUZ-FH15NA	Capacity x 1.0	Capacity x 0.945	Capacity x 0.878	Capacity x 0.771
MUZ-FH18NA				
SUZ-KA09NA	Capacity x 1.0	Capacity x 0.954	Capacity x 0.878	-
SUZ-KA12NA				
SUZ-KA15NA				
SUZ-KA18NA				

M-Series Air Outlet Coverage Range*

Model Number	Mode	Function	Airflow (CFM)	Coverage (ft)
MSZ-GE06NA-9 MSY-GE09NA-9 MSZ-GE09NA-9 MSY-GE12NA-9 MSZ-GE12NA-9	HEAT	DRY	406	29.5
	COOL	WET	286	21.0
MSY-GE15NA-9 MSZ-GE15NA-9	HEAT	DRY	463	33.5
	COOL	WET	385	28.0
MSY-GE18NA-9 MSZ-GE18NA-9	HEAT	DRY	512	36.9
	COOL	WET	385	28.0
MSY-GE24NA MSZ-GE24NA	HEAT	DRY	738	36.9
	COOL	WET	661	33.2
MSY-D30NA-8 MSZ-D30NA-8 MSY-D36NA-8 MSZ-D36NA-8	HEAT	DRY	848	45.0
	COOL	WET	763	40.7
MSZ-FE09NA-8	HEAT	DRY	381	27.7
	COOL	WET	307	22.4
MSZ-FE12NA-8	HEAT	DRY	420	30.4
	COOL	WET	350	25.4
MSZ-FE18NA	HEAT	DRY	738	36.9
	COOL	WET	661	33.2
MSZ-FH09NA	HEAT	DRY	437	29.8
	COOL	WET	328	22.5
MSZ-FH12NA	HEAT	DRY	454	31.0
	COOL	WET	342	23.5
MSZ-FH15NA	HEAT	DRY	497	33.8
	COOL	WET	354	24.1
MSZ-FH18NA	HEAT	DRY	514	23.0
	COOL	WET	376	16.7
MFZ-KA09NA	HEAT	DRY	332	15.4
	COOL	WET	303	14.2
MFZ-KA12NA	HEAT	DRY	335	15.6
	COOL	WET	309	14.5
MFZ-KA18NA	HEAT	DRY	434	20.0
	COOL	WET	379	17.5
SLZ-KA09NA	HEAT	DRY	350	12.1
	COOL	WET	320	1.1
SLZ-KA12NA	HEAT	DRY	390	13.5
	COOL	WET	350	12.1
SLZ-KA15NA	HEAT	DRY	390	13.5
	COOL	WET	350	12.1

*Air coverage represents the distance with one ft/sec air speed when blowing out horizontally from the unit operating at the High fan speed. This is only a general guideline; actual coverage depends on size and layout of the room.

Heating Capacity

Outdoor Temperature Degrees (° F)	-13.0	-4.0	5.0	14.0	23.0	32.0	41.0	50.0
MSZ/MUZ-FH09NA								
Heating Capacity (Btu/h)	7,303	9,047	10,682	10,900	10,900	10,900	10,900	10,900
Percentage of Rated Capacity	67%	83%	98%	100%	100%	100%	100%	100%
MSZ/MUZ-FH12NA								
Heating Capacity (Btu/h)	9,928	11,696	13,600	13,600	13,600	13,600	13,600	13,600
Percentage of Rated Capacity	73%	86%	100%	100%	100%	100%	100%	100%
MSZ/MUZ-FH15NA								
Heating Capacity (Btu/h)	14,580	16,200	18,000	18,000	18,000	18,000	18,000	18,000
Percentage of Rated Capacity	81%	90%	100%	100%	100%	100%	100%	100%
MSZ/MUZ-FH18NA								
Heating Capacity (Btu/h)	14,210	17,255	20,300	20,300	20,300	20,300	20,300	20,300
Percentage of Rated Capacity	70%	85%	100%	100%	100%	100%	100%	100%

Outdoor Temperature Degrees (° F)	-13.0	-4.0	5.0	14.0	23.0	32.0	41.0	50.0
MXZ-2C20NAHZ [Non-Ducted]								
Heating Capacity (Btu/h)	20,460	21,120	22,000	22,000	22,000	22,000	22,000	22,000
Percentage of Rated Capacity	93%	96%	100%	100%	100%	100%	100%	100%
MXZ-3C24NAHZ [Non-Ducted]								
Heating Capacity (Btu/h)	22,500	23,750	25,000	25,000	25,000	25,000	25,000	25,000
Percentage of Rated Capacity	90%	95%	100%	100%	100%	100%	100%	100%
MXZ-3C30NAHZ [Non-Ducted]								
Heating Capacity (Btu/h)	25,168	26,884	28,600	28,600	28,600	28,600	28,600	28,600
Percentage of Rated Capacity	88%	94%	100%	100%	100%	100%	100%	100%
MXZ-4C36NAHZ								
Heating Capacity (Btu/h)	34,200	39,600	45,000	45,000	45,000	45,000	45,000	45,000
Percentage of Rated Capacity	76%	88%	100%	100%	100%	100%	100%	100%
MXZ-5C42NAHZ								
Heating Capacity (Btu/h)	36,480	42,240	48,000	48,000	48,000	48,000	48,000	48,000
Percentage of Rated Capacity	76%	88%	100%	100%	100%	100%	100%	100%
MXZ-8C48NAHZ								
Heating Capacity (Btu/h)	41,040	47,520	54,000	54,000	54,000	54,000	54,000	54,000
Percentage of Rated Capacity	76%	88%	100%	100%	100%	100%	100%	100%

MXZ-Series Accessories

BV-Series Ball Valves



Model numbers:

BV14FFSI2

BV12FFSI2

BV38FFSI2

BV58FFSI2

- ▶ Engineered for Mini-split and Multi-split HVAC Units
- ▶ Full Port Design
- ▶ 700 PSIG Rated
- ▶ R-410A Compatible
- ▶ Flare Connections
- ▶ Forged and machined one piece unibody construction

Part Number	SAE Flare	A	B	C	D	E	F
BV14FFSI2	1/4"	6.26	2.67	1.81	1.23	1.42	1.10
BV38FFSI2	3/8"	6.30	2.67	1.81	1.23	1.42	1.10
BV12FFSI2	1/2"	6.51	2.67	1.81	1.23	1.42	1.10
BV58FFSI2	5/8"	6.64	2.67	1.81	1.23	1.42	1.10

*Ball valves come with an insulation piece

- ▶ Sizes available: 1/4"; 3/8"; 1/2"; 5/8".
- ▶ Fully factory assembled.
- ▶ Furnace brazed and pressure tested.
- ▶ Each ball valve is equipped with 4-1/4" Schrader® valve for refrigerant service.
- ▶ Design working pressure: 700 PSIG.
- ▶ Temperature range: -40° F to +325° F (-40° C to +149° C).
- ▶ Forged and machined brass unibody designed with forged brass seal cap.
- ▶ Polytetrafluoroethylene (PTFE) seals and gaskets (no synthetic O-rings).
- ▶ Seal cap design permits valve operation without removal of seal cap.
- ▶ Uses suitable for with R-11, R-22, R-123, R-125, R-134A, R-236FA, R-4202A, R-402B, R-404A, R-407C, R-410A, R-500, R-502, and R-507.
- ▶ One year limited materials and workmanship warranty on ball valves.

Platform Stands



Lift the Mitsubishi Electric Comfort Solution outdoor unit to new heights with our Diamondback Platform Stands.

- Is easy to install.
- Available for all sizes of M- and P-Series outdoor units.
- Is color matched to the outdoor units.
- One-year warranty.

Model Number: DSD-400N

L: 15-3/4" x W: 3-1/4" x H: 3-1/4"



M-Series Sizing

It is very important that all contractors follow proper procedure and size units based on a Manual J calculation. A load calculation takes into account all the factors that cause the building to lose heat in the winter and gain heat in the summer. Some of the factors taken into consideration are exposed walls, insulation, windows, doors, and even the direction the building faces.

Inverter technology has changed the way heat pumps are used. Because the INVERTER-driven compressor can vary the capacity of the system, we can now size units based on the largest load, which in many cases may be the heat load. When single speed compressors are sized on heat load and changed over to cooling, the units can be grossly over-sized. The result is very little dehumidification and comfort problems.

Using charts like the ones below from the technical service manual, you can check the equipment capacity at the design temperatures for heating and cooling. If these values fall within both the heating and cooling capacity ranges of the system, you can select that system with confidence.

MSZ/MUZ-FH09NA

HEATING CAPACITY

Outdoor Temperature Degrees (° F)	-13.0	-4.0	5.0	14.0	23.0	32.0	41.0	50.0
Heating Capacity (Btu/h)	7,303	9,047	10,682	10,900	10,900	10,900	10,900	10,900
Percent Heating Capacity	67%	83%	98%	100%	100%	100%	100%	100%

COOLING CAPACITY

Indoor Air	Outdoor intake air DB temperature (° F)											
	86			95			104			115		
IWB (° F)	TC	SHC	TPC	TC	SHC	TPC	TC	SHC	TPC	TC	SHC	TPC
71	10.3	6.5	0.63	9.7	6.1	0.68	9.0	5.6	0.72	8.3	5.2	0.75
67	9.7	7.4	0.60	9.0	6.8	0.65	8.4	6.4	0.69	7.7	5.8	0.72
63	9.1	8.1	0.58	8.5	7.6	0.62	7.7	6.9	0.66	7.0	6.3	0.69

Notes: IWB: Intake air wet-bulb temperature

TC: Total capacity

SHC: Sensible heat capacity

TPC: Total power consumption (kW)

Controllers

MHK1 Wireless

Remote Controller Kit

Exclusive for INVERTER-driven M- and P-Series Systems



Wireless Wall-mounted Remote Controller

- ▶ Backlit, easy-to-read display.
- ▶ Dual setpoint control with system changeover.
- ▶ Enabled with RedLINK™ reliability.
- ▶ Installs anywhere with simple wall-mounted design.
- ▶ Compatible with MCCH1 Portable Central Controller and MOS1 Outside Air Sensor.
- ▶ Requires wireless interface (included in kit).

MIFH1 Wireless Receiver

- ▶ Required for MRCH1 Wireless Remote Controller.
- ▶ Enabled with RedLINK reliability.

Controllers

MHK1 Wireless Remote Controller Kit



MCCH1

Portable Central Controller

- ▶ Up to 16 RedLINK™ devices.
- ▶ Requires MHK1 per indoor unit.
- ▶ Monitor and control On/Off, Mode, and Set Temp.
- ▶ Schedule override capability.
- ▶ Does not interfere with other wireless devices.
- ▶ Displays outside air temperature and humidity when used with MOS1.



MOS1

Outside Air Sensor

- ▶ Monitors outside air temperature and humidity.
- ▶ Displays on MHK1 Wireless Wall-mount Remote Controller and MCCH1 Portable Central Controller.

Controllers



Thermostat Interface

Our Thermostat Interface allows HVAC thermostats or input/output controllers to control Mitsubishi Electric Cooling & Heating commercial or residential indoor units through our CN105 connector. Any indoor unit that can be controlled by MHK1 can now be controlled by a third party HVAC thermostat or input/out controller.

This allows Mitsubishi Electric systems to use the capabilities of third party thermostats including but not limited to:

- ▶ Geo-fencing.
- ▶ Automatic scheduling.
- ▶ Humidity control.
- ▶ Set temperature range (dependent on indoor unit)
- ▶ Weather forecasting and more.

Our patent-pending algorithm allows the outdoor unit's INVERTER-driven compressor to vary its capacity for greater energy savings. The preferred system setup is to use a conventional system control with two stages of heating and cooling (W1, W2, Y1, and Y2). This will provide the most comfort and energy savings. The interface can be setup to accept only one stage of heating and cooling (W1 and Y1).

Mitsubishi Electric Thermostat Interface also allows for fan speed control. Third party thermostats or input/output controllers can control the indoor unit's fan speed to three different levels: High, medium, and low.

Controllers

Specifications

- ▶ Allows an HVAC Thermostat or I/O Controller to control a Mitsubishi Electric Cooling & Heating [CITY MULTI, M-Series or P-Series] indoor unit.
- ▶ One Thermostat Interface per indoor unit.
- ▶ Indoor unit modes available: Cool, Heat, Fan, and Off.
- ▶ Provides 3 input terminals to control fan speed control: High, Medium, and Low.
- ▶ Addressing: No addressing required.
- ▶ Connection: CN105 – Active IT Terminal.
- ▶ Thermostats Tested:
 - Nest®
 - Honeywell® Lyric™
 - INNCOM® by Honeywell® with High and Low fan speed control.
- ▶ Dimensions: (H x W x D) 3.96 in x 3.17 in x 0.93 in.
- ▶ Terminal Block: 20-30 VAC Rated.
- ▶ **Required:** Active CN105 on Mitsubishi Electric indoor unit control board.
- ▶ **Required:** HVAC Thermostat or I/O Controller (field supplied).
- ▶ **Required:** 24VAC circuit for HVAC Thermostat (field supplied).

Advanced Features

- ▶ Delayed off adjustable setting.
- ▶ Static pressure adjustable setting.
- ▶ CN24 operation during defrost.
- ▶ Fan speed during thermal off heating mode.
- ▶ Two-stage heat and cool thermostat operation.
- ▶ Conventional 2h/2c system operation (preferred).
- ▶ Conventional 1h/1c system operation.
- ▶ Auto recovery after power failure.
- ▶ Thermostat detects room temperature.

Controllers

MHK1 Wireless Remote Controller Kit



Function	Description
ON/OFF	On/Off operation for a single indoor unit
Operation Mode	Cool / Drying / Auto / Heat / Fan only Available operation modes dependent upon connected system.
Temperature Setting	Set temperature from 40° F – 99° F depending on operation mode and connected system
System Changeover Deadband Value	2° F - 8° F
Schedule Operation	5-2, 5-1-1
Fan Speed Setting	Hi/Mid-2/Mid-1/Low/Auto. Available fan speed settings dependant upon connected system.
Air Flow Direction Setting	Airflow angles: 100° - 80° - 60° - 40° and oscillate. Available air flow direction settings dependent upon connected system.
Permit/Prohibit Function	Individual prohibit operations for each remote controller function (ON/OFF, Set Temperature, and Mode).
Space Temperature	Displays the measured space temperature.
Error Indication	Displays error code.
Display Outside Temperature and Humidity	Requires optional MOS1 Outside Air Sensor
Dimensions - (W x D x H)	Remote Controller: 5-3/16" x 1-1/2" x 3-9/16" Receiver: 3-1/4" x 1-5/16" x 6-7/16"
Operating Ambient Temperature	Remote Controller: 32 - 120° F Receiver: -40 – 165° F
Operating Ambient Humidity	Remote Controller: 5 percent - 90 percent RH (non-condensing) Receiver: 5 percent - 90% RH (non-condensing)
Power Supply	2 AA batteries (included)

Controllers

Handheld

Wireless Controller

Wireless

Standard for M-Series wall-mounted and floor-mounted systems and optional for P-Series indoor units



Powerful Mode and
Wide Vane Control buttons are
available on models
MSY(Z)-GE24/D30/D36NA

GE model remote
shown, models vary

Controllers

Wired Controllers

Simple MA

Controls group operation for up to 16 indoor units in a single group

- ▶ Supports both Fahrenheit and Celsius.
- ▶ User defined functions:



PAC-YT53CRAU

- ON/OFF.
- Operation mode: AUTO (R2-Series only), COOL, HEAT, FAN, DRYING, or SETBACK.
- Set temperature.
- Fan speed setting.
- Air flow direction.
- Set temperature range: 40° F - 95° F depending on operation mode and indoor unit connected.

- ▶ Set temperature range limit can be reduced for cool and heat modes.
- ▶ LOSSNAY®: Simple MA for interlocked system can set high/low/Stop on LOSSNAY.
- ▶ Room temperature can be sensed either at the indoor unit (default) or at the remote controller.
- ▶ Diagnostics: Displays four-digit error code and error unit address.
- ▶ Grouping: Same group use only with other PAC-YT53CRAU Simple MA Controllers, PAR-31MAA Wired MA Remote Controllers, and PAR-FL/A32MA Wireless MA Remote Controllers with up to two remote controllers per group.
- ▶ Addressing: No addressing required.
- ▶ Wiring: connects using two-wire, stranded, non-polar control wire to indoor unit connection terminal or control adapter (MAC-333IF for M-Series) requires crossover wiring for indoor unit grouping.
- ▶ Dimensions: 2-3/4" x 9/16" x 4-3/4" (70mm x 14.5mm x 120mm).

Controllers

Wired Controllers

Wired MA



PAR-31MAA

Controls group operation for up to 16 indoor units in a single group

- ▶ Features selectable multi-lingual LCD (English, Spanish, and French).

User functions allow user to set:

- ▶ Timer Operation:
 - Weekly Timer: On/Off/ Temperature setting up to 8 times per day of the week in 1-minute increments.
 - Simple Timer: On and Off time can be set once within 72-hour period in 1-hour increments.
 - Auto-off Timer: Turns indoor unit Off based on countdown time up to 4-hours in 30-minute increments.
- ▶ Room Temperature: Displays room temperature sensed either at the indoor unit (default) or at the remote controller.
- ▶ Set Temperature Range Limit: From the Backlit MA Controller, the allowable set temperature range can be reduced for cool and heat modes.
- ▶ Special Function Rotation/ Backup (Lead/Lag for P-Series).
- ▶ Static pressure setting (model dependent)
- ▶ Fan speed setting for use with supplemental heating function (model dependent).
- ▶ Function Lock Out: Prohibits all functions or all functions except On/Off from the backlit MA controller.
- ▶ Wiring: connects using two-wire, stranded, non-polar control wire to indoor unit connection terminal or control adapter (MAC-333IF for M-Series) requires crossover wiring for indoor unit grouping.
- ▶ Dimensions: 4-3/4" x 3/4" x 4-3/4" (120mm x 19mm x 120 mm)

P-Series Indoor Units

Connect to cooling-only PUY and heat pump PUZ
INVERTER-driven compressor outdoor units.

PKA Wall-mounted Series Cooling-only and Heat Pumps

(12,000 to 34,200 Btu/h)

- ▶ Provides cooling and heating in a wide range of capacities.
- ▶ Auto flap shutter.
- ▶ Auto fan control.
- ▶ Easy-clean washable filters.
- ▶ Multiple controller options.



PCA Ceiling-suspended Series Cooling-only and Heat Pumps

(24,000 to 42,000 Btu/h)

- ▶ i-see™ Sensor optional.
- ▶ Knockout for ventilation air.
- ▶ Auto fan speed control.
- ▶ Optional, high-efficiency filter.
- ▶ Multiple controller options.



PLA Ceiling-recessed Series Cooling-only and Heat Pumps

(12,000 to 42,000 Btu/h)

- ▶ Built-in condensate lift mechanism (33" lift).
- ▶ Branch duct outlet.
- ▶ i-see™ Sensor optional.
- ▶ Knockout for ventilation air.
- ▶ Multiple controller options.



PVA Multi-position Air Handling Units

Provides cooling and heating to larger zones

(18,000 to 42,000 Btu/h)

- ▶ Performance: One inch foam R4.2, fiberglass-free insulation reduces condensation and boosts efficiency.
- ▶ Quality: durable, powder coated cabinet.
- ▶ Serviceability: easily removable fan provides access for coil cleaning.
- ▶ Flexibility: true multi-position, requiring no additional kits for downflow configuration.
- ▶ Installation: quality construction with disassembly in mind to make fitting through tight access points simple.
- ▶ Comfort: DC motor ensures quiet and efficient operation year round.
- ▶ Low Impact: fully RoHS compliant to reduce carbon footprint.
- ▶ Air Quality: positively pressurized cabinet and tested air leakage less than 1%.



PEA/PEAD Horizontal Ducted Series

Cooling-only and Heat Pumps

(12,000 to 42,000 Btu/h)

- ▶ Automatic fan speed control.
- ▶ Built-in condensate lift mechanism (21 11/16" PEA, 27 9/16" PEAD lift).
- ▶ Adjustable static pressure.
- ▶ Multiple controller options.



P-Series Systems

Specifications (Cooling Only)

Indoor Unit Model #	PEA-A12AA6 PKA-A12HA6 PLA-A12BA6	PEA-A18AA6 PKA-A18HA6 PLA-A18BA6	PEAD-A24AA5 PKA-A24KA6 PLA-A24BA6 PCA-A24KA6	
Outdoor Unit Model #	PUY-A12NHA6(-BS)	PUY-A18NHA6(-BS)	PUY-A24NHA6(-BS)	
Cooling Capacity Range (Btu/h)	6,000-12,000	8,000-18,000	12,000-24,000	
SEER Range	14.0-15.2	14.2-15.3	14.0-17.0	
Lineset Size (Liquid x Gas)	1/4" x 1/2"	1/4" x 1/2"	3/8" x 5/8"	
Lineset Length/Height Max Separation	165'/100'	165'/100'	225'/100'	

Test conditions are based on AHRI 210/240.

- ▶ BS= Seacoast Protection Coating
- ▶ P-Series models 12K-36K Btu/h are pre-charged for up to a 70' line set. PUY/Z-A42NHA5 and H2i models are pre-charged for up to a 100' line set.

	PEAD-A30AA5 PKA-A30KA6 PLA-A30BA6 PCA-A30KA6	PEAD-A36AA5 PKA-A36KA6 PLA-A36BA6 PCA-A36KA6	PEAD-A42AA5 PLA-A42BA6 PCA-A42KA6
	PUY-A30NHA6(-BS)	PUY-A36NHA6(-BS)	PUY-A42NHA6(-BS)
	12,000-30,000	12,000-35,000	18,000-42,000
	14.0-17.0	14.0-15.0	14.0-15.8
	3/8" x 5/8"	3/8" x 5/8"	3/8" x 5/8"
	225'/100'	225'/100'	225'/100'

P-Series Systems

Specifications (Heat Pump)

Indoor Unit Model #	PEA-A18AA6 PKA-A18HA6 PLA-A18BA6	PEAD-A24AA6 PKA-A24KA6 PLA-A24BA6 PCA-A24KA6	PEAD-A30AA5 PKA-A30KA6 PLA-A30BA6 PCA-A30KA6	PEAD-A36AA5 PKA-A36KA6 PLA-A36BA6 PCA-A36KA6	
Outdoor Unit Model #	PUZ-A18NHA6 (-BS)	PUZ-A24NHA6 (-BS)	PUZ-A30NHA6 (-BS)	PUZ-A36NHA6 (-BS)	
Cooling Capacity Range (Btu/h)	8,000-18,000	12,000-24,000	12,000-30,000	12,000-35,000	
Heating Capacity Range (Btu/H)	8,000-20,000	12,000-28,000	12,000-34,000	12,000-38,000	
SEER/ HSPF Range	14.2-15.3/ 9.5-10.0	14.0-17.0/ 8.5-10.9	14.0-15.5/ 8.7-9.4	14.0-15.0/ 9.3-10.2	
Lineset Size (Liquid x Gas)	1/4" x 1/2"	3/8" x 5/8"	3/8" x 5/8"	3/8" x 5/8"	
Lineset Length/ Height Max Separation	100'/100'	165'/100'	165'/100'	165'/100'	

Test conditions are based on AHRI 210/240.

- ▶ BS= Seacoast Protection Coating
- ▶ P-Series models 12K-36K Btu/h are pre-charged for up to a 70' line set. PUY/Z-A42NHA6 and H2i models are pre-charged for up to a 100' line set.



	PEAD-A42AA5 PLA-A42BA6 PCA-A42KA6	PEAD-A30AA5 PKA-A30KA6 PLA-A30BA6 PCA-A30KA6 PVA-A30AA4	(2) PEA-A18AA6 PEAD-A36AA5 PKA-A36KA6 PLA-A36BA6 PCA-A36KA6 PVA-A36AA4	PEAD-A42AA5 PKA-A42KA6 PLA-A42BA6 PCA-A42KA6 PVA-A42AA4
	PUZ-A42NHA6 (-BS)	PUZ-HA30NHA6	PUZ-HA36NHA6	PUZ-HA42NKA
	18,000-42,000	18,000-30,000	18,000-36,000	18,000-42,000
	18,000-48,000	18,000-34,000	18,000-40,000	18,000-42,000
	14.0-15.8/ 9.3-10.2	15.6-16.5/ 9.3-9.5	16.2-17/ 10-10.4	14.3-17.8/ 10-11.0
	3/8" x 5/8"	3/8" x 5/8"	3/8" x 5/8"	3/8" x 5/8"
	165'/100'	245'/100'	245'/100'	245'/100'

P-Series Systems

Correction Factors

Cooling Capacity Correction Factor (x capacity)

Outdoor Unit	Refrigerant piping length (one way)					
	16 ft	33 ft	70 ft	100 ft	130 ft	165 ft
PUY-A12/18NHA6 PUZ-A18NHA6	1.00	0.985	0.948	0.916	0.886	0.859
PUY-A24-36NHA6 PUZ-A24-36NHA6	1.00	0.988	0.964	0.938	0.915	0.893
PUY-A42NHA6 PUZ-A42NHA6	1.00	0.985	0.948	0.916	0.886	0.859

Hyper-Heating INVERTER (H2i®)

Cooling Capacity Correction Factors (x capacity)

Outdoor Unit	Refrigerant piping length (one way)					
	16 ft	33 ft	70 ft	100 ft	130 ft	
PUZ-HA30NHA6 PUZ-HA36NHA6 PUZ-HA42NKA	1.00	0.985	0.957	0.931	0.908	

Heating Capacity Correction Factors (x capacity)

Outdoor Unit	Refrigerant piping length (one way)					
	16 ft	33 ft	70 ft	100 ft	130 ft	
PUZ-HA30NHA6 PUZ-HA36NHA6 PUZ-HA42NKA	1.00	0.997	0.991	0.985	0.979	

Heating Capacity Correction Factors (x capacity)

Outdoor Unit	Refrigerant piping length (one way)					
	16 ft	33 ft	70 ft	100 ft	130 ft	165 ft
PUZ-A18NHA6	1.00	0.997	0.991	0.985	–	–
PUZ-A24-36NHA6	1.00	0.997	0.991	0.985	0.979	0.973
PUZ-A42NHA6	1.00	0.997	0.991	0.985	0.979	0.973

Refrigerant piping length (one way)					
165 ft	180 ft	195 ft	230 ft	260 ft	
0.886	0.876	0.865	0.846	0.829	

Refrigerant piping length (one way)					
165 ft	180 ft	195 ft	230 ft	260 ft	
0.973	0.970	0.967	0.961	0.955	

P-Series Air Coverage Range

Outlet Air Speed and Coverage Range*

Model	Airflow (CFM)	Air Speed (ft/sec)	Coverage Range (ft)
PLA-A12BA6	530	8.5	13
PLA-A18BA6	640	10.5	15
PLA-A24BA6	640	10.5	15
PLA-A30BA6	740	12.1	18
PLA-A36BA6	1060	17.4	26
PLA-A42BA6	1090	17.7	26
PKA-A12HA6	425	20.0	35
PKA-A18HA6	425	20.0	35
PKA-A24KA6	775	19.7	47
PKA-A30KA6	775	19.7	47
PKA-A36KA6	920	22.3	53
PCA-A24KA6	670	10.2	32
PCA-A30KA6	705	10.5	33
PCA-A36KA6	990	11.8	41
PCA-A42KA6	1,025	12.1	42

*Air coverage represents the distance with 0.8 ft/sec air speed when blowing out horizontally from the unit operating at the High fan speed. This is a general guideline; actual coverage depends on size and layout of the room.

Installation

Required Tools for Installation

- Phillips screwdriver.
- Pipe cutter with reamer.
- Level.
- Flaring tool.
- Scale.
- Nitrogen.
- Utility knife or scissors.
- Vacuum pump.
- Micron gauge.
- 3" (75mm) hole saw.
- Charge hose for R410A.
- 1/4" - 5/8" torque wrench.
- Gauge manifold for R410A.
- 5/32" (4mm) hexagonal wrench.
- Adjustable wrenches.

Condensate Drain Pipe Installation

Yes:

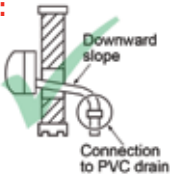

No:

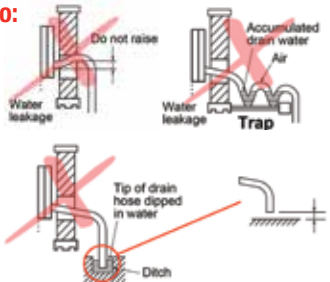

M-Series Wall-mounted System Clearances

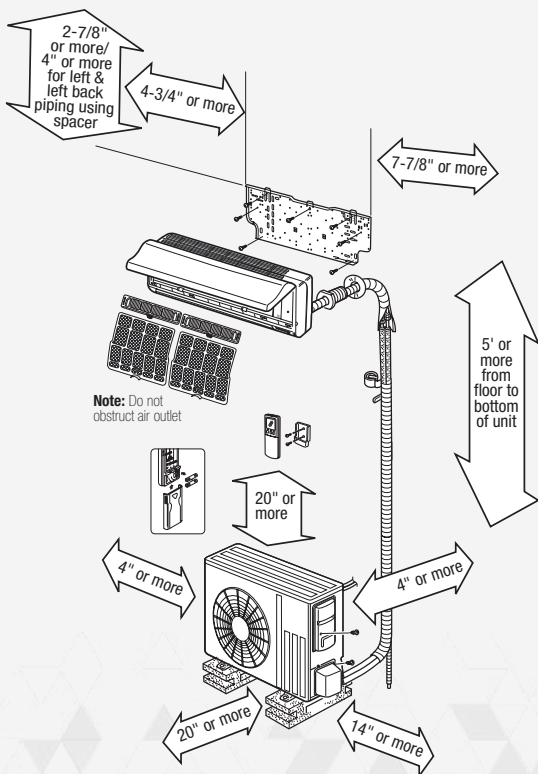

Applies to all M-Series models except MXZ-8C48NA.
Check installation instructions for your exact model.

P-Series Outdoor System Clearances

To illustrate the minimum space required around the outdoor unit, the clearances for all P-Series models are shown below. See installation manual for the minimum clearances by model.

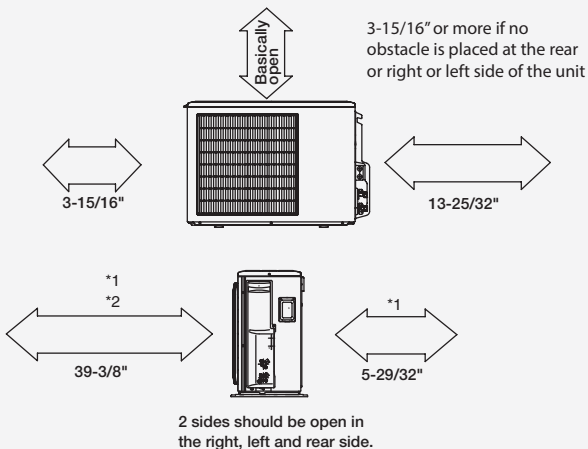

Minimum installation space for outdoor unit

- *1. In a place where short cycling can occur, cooling and heating capacity will decrease and power consumption will increase by 10 percent. Air outlet guide (PAC-SG58SG-E for PUY/PUZ-A12/18NHA or PAC-SG59SG-E for PUY/PUZ-A124/30/42NHA) will help improve capacity.
- *2. If air is discharged onto a wall, the surface may discolor.

Installation

Refrigerant Piping

Installing Refrigerant Piping

For "Twinning" indoor units for better airflow coverage in a large or L-shaped room (For A24/A36, and HA36 outdoor units only).

Refrigerant piping limitations of length and height difference are shown in the figure below.

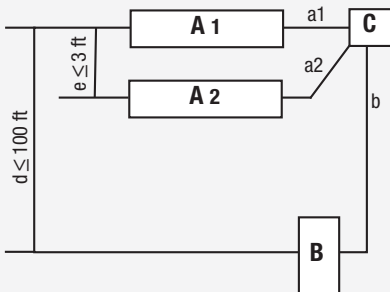

Max. length, PUY/PUZ-A24/36NHA systems:

$$a1 + a2 + b \leq 165 \text{ ft}$$

Max. length, PUZ-HA36NHA hyper-heating systems:

$$a1 + a2 + b \leq 245 \text{ ft}$$

Key:

A = Indoor unit

B = Outdoor unit

C = Multi distribution pipe (option)

d = Height difference (Indoor unit-Outdoor unit) Max. 100 ft.

e = Height difference (Indoor unit-Indoor unit) Max. 3 ft.

How to Check for Refrigerant Restriction:

1. Verify the refrigerant charge.
 - Remove the charge and weigh it back in.
 - Make sure the system has the refrigerant amount specified for the line length (see Service Manual).
2. Measure for temperature differences across evaporator.
 - Set unit operation to cooling and change temperature set point to lowest degree available, or switch system to emergency COOL mode.
 - Change fan operation to high speed.
 - Run system for five minutes, and then measure both the entering and leaving air temperatures with a thermometer.
 - The temperature differential should be around 20° F to 23° F (see Service Manual).
 - Remove the charge and weigh it back in.
 - Make sure the system has the refrigerant amount specified for the line length (see Service Manual). Assuming you have verified the charge, a difference of less than 20° F means the system is restricted.

A difference of 23° F or more usually means low airflow, often because dirt has built up on the fan blades. Clean the fan and coil and check temperatures again.

Note: When testing the system, remember to change the fan operation to high speed and verify that the unit is charged with the proper amount of refrigerant.

Installation

Wiring: M-Series and P-Series

- ▶ Indoor unit power is supplied from the outdoor unit.
- ▶ On M-Series models, use AWG-14-3 600 VAC-rated copper wiring between outdoor unit and indoor unit for high voltage and controls circuits.
- ▶ On P-Series models, use AWG-16-3 600 VAC-rated copper wiring between outdoor unit and indoor unit for high voltage and controls circuits.
- ▶ If larger gauge wiring is required by code – use that on S1 and S2 terminals while using proper wire size on S3 communication terminal (16 gauge on P-Series and 14 gauge on M-Series).
- ▶ Two types of connection patterns, for 1:1 system and for P-Series "twin" operation ("twinning") are shown in the diagrams at right.

Key:

A = Outdoor unit power supply

B = Wiring circuit breaker or isolating switch

C = Outdoor unit

D = Indoor unit/Outdoor unit connecting wiring

E = Remote control

F = Indoor unit

Note: All wiring shall comply with NEC and local electrical codes. See unit installation manual for details.

Notes:

* A disconnect switch may be required at indoor unit.

** Use a ring tongue terminal if AWG12 wire is used.

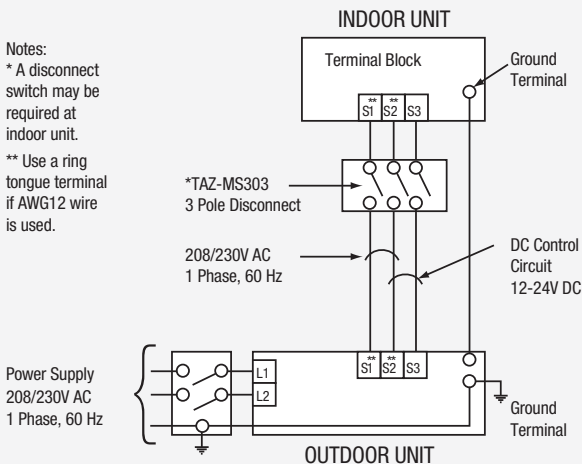

"Twinning" Operation

Power Supply
208/230V AC

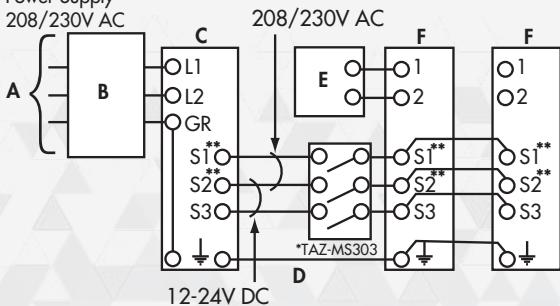

Installation

Test Run

1. Turn power on to outdoor unit.
2. Press the emergency operation button once. The test will run for 30 minutes. If the LED light blinks every 0.5 seconds, verify the indoor/outdoor connecting wire is installed properly. After the test run, the emergency COOL mode (75° F) will operate.
3. To stop operation, press the emergency operation button several times until all LED lights turn off. See operation manual for details.

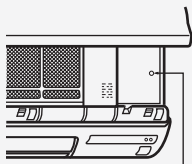

Emergency operation switch (E.O. SW)

Checking the Remote (Infrared) Signal Reception

1. Press the ON/OFF button on the remote controller and listen for a beep from the indoor unit.
2. Press the ON/OFF button again to turn the air conditioner off.
3. After the compressor stops in the outdoor unit, the restart prevention device will activate. This causes the compressor to stop operation for three minutes, which protects the air conditioner.

Caution:

After finishing the test run or checking the remote (infrared) signal reception, use emergency operation button or remote controller to turn unit off before turning power supply off. If this sequence is not followed properly, the unit will start operating automatically when the power supply resumes.

Need Help When You Are On The Jobsite?

Check out www.mylinkdrive.com

Here you can find: service bulletins, FAQs, Guide Specs, Install Manuals, MSDS sheets, Operation Manuals, Parts Lists, Service Manuals, Submittals, Accessories and the M&P troubleshooter.

Auto Restart Function:

Mitsubishi Electric systems are equipped with an auto restart function. If the power shuts off while the system is operating (blackouts, etc.), the system will automatically resume operation at the previous setting after the power resumes. If the end user prefers not to use this function, a service representative can deactivate it. See Operation Manual for details.

Necessary End User Information:

After installation, show the end user how to operate the system remote controller and remote controller holder, remove the air filter, cleaning methods, operating precautions, etc. Recommend that the end user read the Operation Manual.

Continuous Fan Operation:

Explain to the end user that the indoor unit fan is designed to continuously run air across the filters. A sensor also constantly measures room temperature to maintain set point. These functions help improve air quality and reduce wear and tear on the fan motor.

Ducting Considerations

Ducting Considerations for the PEA/PEAD/SEZ Horizontal Ducted Indoor Unit

Considering the performance and design of these indoor units, selection and proper duct sizing and installation are necessary for satisfactory operation.

The maximum available static pressure from the PEA and SEZ indoor units is 0.2 in. W.G. and for the PEAD indoor units 0.6 in. W.G.

Most of the static pressure duct loss comes from allowing the duct work to sag. Allowing even a 30 percent sag in the ductwork can increase the static pressure loss up to eight times. Flexible ductwork runs should be kept to less than 15 ft.

Airflow (CFM)	50	100	150	200	250
Grille Size (In. x In.)	6x6	6x6	8x6	10x6, 8x8	12x6, 10x8

Inches of Static Pressure Loss per 100 ft. of hard duct				
	4"Ø	6"Ø	8"Ø	10"Ø
50 CFM	0.15	0.02	-	-
100 CFM	0.6	0.08	0.02	-
150 CFM	-	0.2	0.04	-
200 CFM	-	0.3	0.08	0.02
250 CFM	-	0.45	0.11	0.04
500 CFM	-	-	0.4	0.15

LIMITED WARRANTY INFORMATION



Effective APRIL, 2015

M-Series Warranty:

- ▶ 12-year parts and 12-year compressor warranty is available to the original owner provided the system is:
 - Installed by a Diamond Contractor in a residential single-family owner-occupied home.
 - Registered by the installing contractor through the Extranet within 90 days of installation.
- ▶ 10-year parts and 10-year compressor warranty is available to the original owner provided the system is:
 - Installed by a licensed contractor in a residential single-family owner-occupied home.
 - Registered through the MitsubishiComfort.com site, within 90 days of installation.
- ▶ 5-year parts and 7-year compressor warranty will come standard to the original owner.

P-Series Warranty:

- ▶ 12-year parts and 12-year compressor warranty is available to the original owner provided the system is:
 - Installed by a Diamond Contractor in a residential single-family owner-occupied home.
 - Registered through the Extranet within 90 days of installation.
- ▶ 10-year parts and 10-year compressor warranty is available to the original owner provided the system is:
 - Installed by a licensed contractor in a residential single-family or commercial application.
 - Registered through the MitsubishiComfort.com site within 90 days of installation.
- ▶ 5-year parts and 7-year compressor warranty will come standard to the original owner.

The full text of this Limited Warranty is available on the Mitsubishi Electric website. The Limited Warranty gives the owner specific legal rights and the owner may also have other rights that vary from state to state. Some states do not allow limitations on warranties or exclusions or limitation of damages, so the specified limitations or exclusions may not apply. This Limited Warranty is valid only in the continental United States, Alaska and Hawaii and is not transferable.

For more information, contact: Customer Care: 800-433-4822

Web: <http://www.mitsubishipro.com>

Synchrony Financing

Getting Started is as Easy as 1,2,3!

Go to toolbox and take selling strategies:

- ▶ toolbox.mysynchrony.com/diamondEnroll.
- ▶ Download the rate menu for available plans.
- ▶ Follow the Commitments guide focusing on getting team trained. Download this Synchrony Contacts flier for training and more information.

Think Outside the Toolbox!

Announcing the Selling In The Home Webinar Training Series

What if you worked as hard on your business as you work in your business? You use your knowledge and skill to choose the right tool for the job. So why not put that same sharp focus to work growing your business? Synchrony Financial is excited to invite you to Think Outside the Toolbox—a website dedicated to helping you grow your business by closing more projects.

As part of our commitment to bringing you useful tools and fresh ideas, we've leveraged insights from our largest partners in the Home Improvement, HVAC, Spa and Landscape industries, and combined them with Synchrony Financial's expertise. In addition, Synchrony Financial teamed up with Dave Yoho Associates to develop the materials in the Selling In The Homewebinar series. We invite you to take advantage of all this knowledge and experience today.

Take the first step toward growing your business by visiting our Think Outside the Toolbox website at: toolbox.mysynchrony.com/diamond

Once there, you will complete a quick site registration and be offered two series of training webinars. Each webinar training series consists of two 15-20 minute webinars, and two short quizzes.

In the Selling In The Home webinar series you will learn:

- ▶ The critical role of consumer financing throughout the sales process.
- ▶ Common myths about financing.
- ▶ How to set a good first impression with the customer.
- ▶ Tips on how to present your company and products.
- ▶ How to close the sale leveraging special promotional financing options.

Receive a \$25 Visa® Gift Card* for completing each webinar training series and corresponding quizzes.



MAKE COMFORT *Personal*[™]

Mitsubishi Electric, H2i, CITY MULTI, Lossnay and the three diamond logo are registered trademarks of Mitsubishi Electric Corporation. Lyric, Incom and RedLink are trademarks of Honeywell Corporation. Nest is a trademark of Google, Inc. Use of the AHRI Certified[™] indicates a manufacturer's participation in the certification program. For verification of certification for individual products, go to www.ahridirectory.org.

See complete warranty for terms, conditions, and limitations.

A copy is available from:

Mitsubishi Electric, 1340 Satellite Blvd, Suwanee, GA 30024

Specifications subject to change without notice.

For more information visit www.mehvac.com



MQR 10.2015 REVISED SKU: MQR0710_V1

Customer Care: 800-433-4822 | Printed In The U.S.A

©2015 Mitsubishi ElectricUS, Inc.