

MOVINCOOL®

**SERVICE
MANUAL**

CLIMATE PRO® K18

SERIAL NUMBER LOCATION

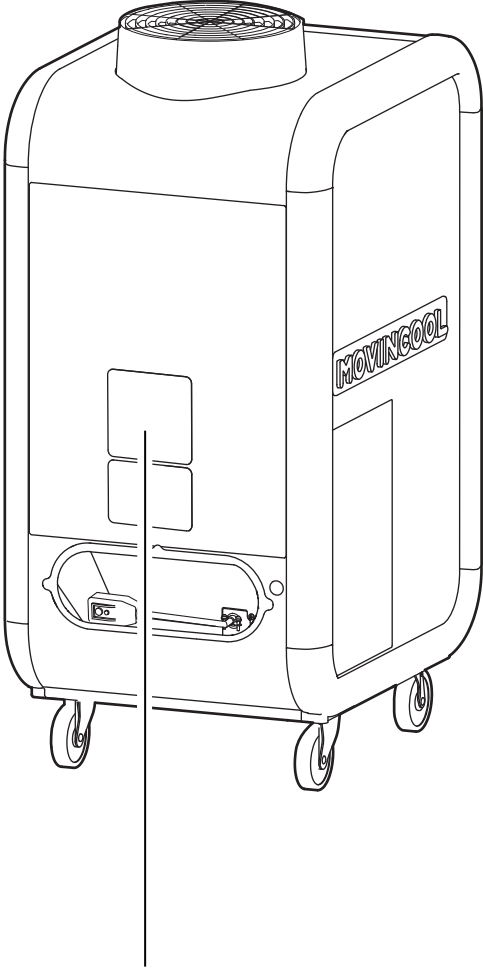

00 00 0000 000
Month Year Sequential Model
number name

© 2020 DENSO PRODUCTS AND SERVICES AMERICAS, INC. All rights reserved. MovinCool® and Climate Pro® are registered trademarks of DENSO Corporation.

TABLE OF CONTENTS

SERIAL NUMBER LOCATION	2
SAFETY PRECAUTIONS	5
CONSTRUCTION	7
Dimensions	7
Names of Parts	8
Internal Structure	9
SPECIFICATIONS	10
Technical Specifications	10
Characteristics	12
SERVICE INFORMATION	13
Machine Status	13
Machine Records	14
TROUBLESHOOTING	15
Initial Inspection	15
Self-Diagnostic Codes	16
Troubleshooting Chart	17
Inspection Before Disassembly	20
DISASSEMBLY	21
Structure Parts	21
Removal of Panels	22
Removal of Louver	25
Removal of Bumpers	26
Removal of Electrical Parts	28
Removal of Antenna	31
Removal of Communication Module	32
Removal of Blower Assembly	37

TABLE OF CONTENTS

- INSPECTION OF PARTS..... 40**
 - Capacitor40
 - Drain Switch40
 - Fan Motor41
 - Compressor42
 - Thermistor43

- REFRIGERATION SYSTEM REPAIR..... 44**
 - Brazing44
 - Replacement of Refrigeration Cycle Parts46
 - Charging the System with R-410A Refrigerant48



- REASSEMBLY52**
 - Wiring Diagram 52
 - Compressor Mounting 53
 - Caster Maintenance 53

- DATA PRIVACY DISCLOSURE 54**

SAFETY PRECAUTIONS



To reduce the risk of injury or malfunction, read “Safety Precautions” carefully before servicing the unit.

The seriousness is classified by the following indicators.







 WARNING	<p>Indicates a hazardous situation which, if not avoided, could result in death or serious injury.</p>
 CAUTION	<p>Indicates a hazardous situation which, if not avoided, could result in minor or moderate injury, damage to the unit or its components and/or property.</p>

- Serious injuries include loss of vision, bodily injuries, burns, electric shock, fractures or poisoning, which require prolonged medical treatment and will leave after-effects.
- Minor or moderate injuries include bodily injuries, burns or electric shock, which do not require prolonged medical treatment.
- Property includes housing, household goods, livestock or pets.





Safety symbols and meanings

 This must be done.	 This must not be done.
-------------------------------------------------------------------------------------------------------------	-----------------------------------------------------------------------------------------------------------------



 **WARNING**

	<p>Disconnect power supply from the unit before performing any service. Beware that some residual voltage may remain in the unit immediately after the power is disconnected. There is a risk of electric shock.</p>
	<p>Use the power supply dedicated single outlet circuit with a UL recognized short-circuit and ground-fault protective breaker. Failure to use correct power supply may cause fire or electric shock.</p>
	<p>Electrical work must be performed by qualified electrical personnel. Failure to use qualified electrical personnel for electrical work may cause fire, electric shock, injury, malfunction or water leaks.</p>
	<p>Refrigerant services must be performed by a licensed professional only. Failure to use licensed professionals for refrigerant services may cause fire, burns, injury or malfunction.</p>
	<p>Always wear proper eye protection and gloves while handling refrigerant. Be careful not to allow refrigerant come into contact with eye or skin. Failure to do so may lead to loss of vision or burns.</p>
	<p>Avoid refrigerant work near flammable materials. Work in a well-ventilated area only. Failure to do so may lead to explosion, fire or lack of oxygen.</p>

 **WARNING**

- | | |
|-----------------------------------------------------------------------------------|---------------------------------------------------------------------------------------------------------------------------------------------------------|
|  | Maintain the temperature of the refrigerant container below 104 °F (40 °C).
Failure to do so may lead to explosion or fire. |
|  | Brazing must be performed by a qualified technician only.
Failure to do so may lead to fire, burns, injury or malfunction. |
|  | When brazing, always wear eye protection and gloves.
Failure to do so may lead to loss of vision or burns. |
|  | Work in a well-ventilated area while brazing.
Failure to do so may lead to explosion, fire or lack of oxygen. |
|  | Use official MovinCool parts for servicing.
Non-genuine accessories or incomplete installation may cause fire, electric shock or water leaks. |

 **CAUTION**

- | | |
|-------------------------------------------------------------------------------------|-------------------------------------------------------------------------------------------------------------------------------------|
|  | Be aware of any sharp edges when working on unit.
There is a risk of injury. |
|  | Do not use sharp object to press the reset button when resetting communication module.
This may damage the control panel. |
|  | Do not use cleaners that contain chlorine when cleaning pipes of refrigerant system.
Chlorine cleaners may damage pipes. |

CONSTRUCTION

Dimensions

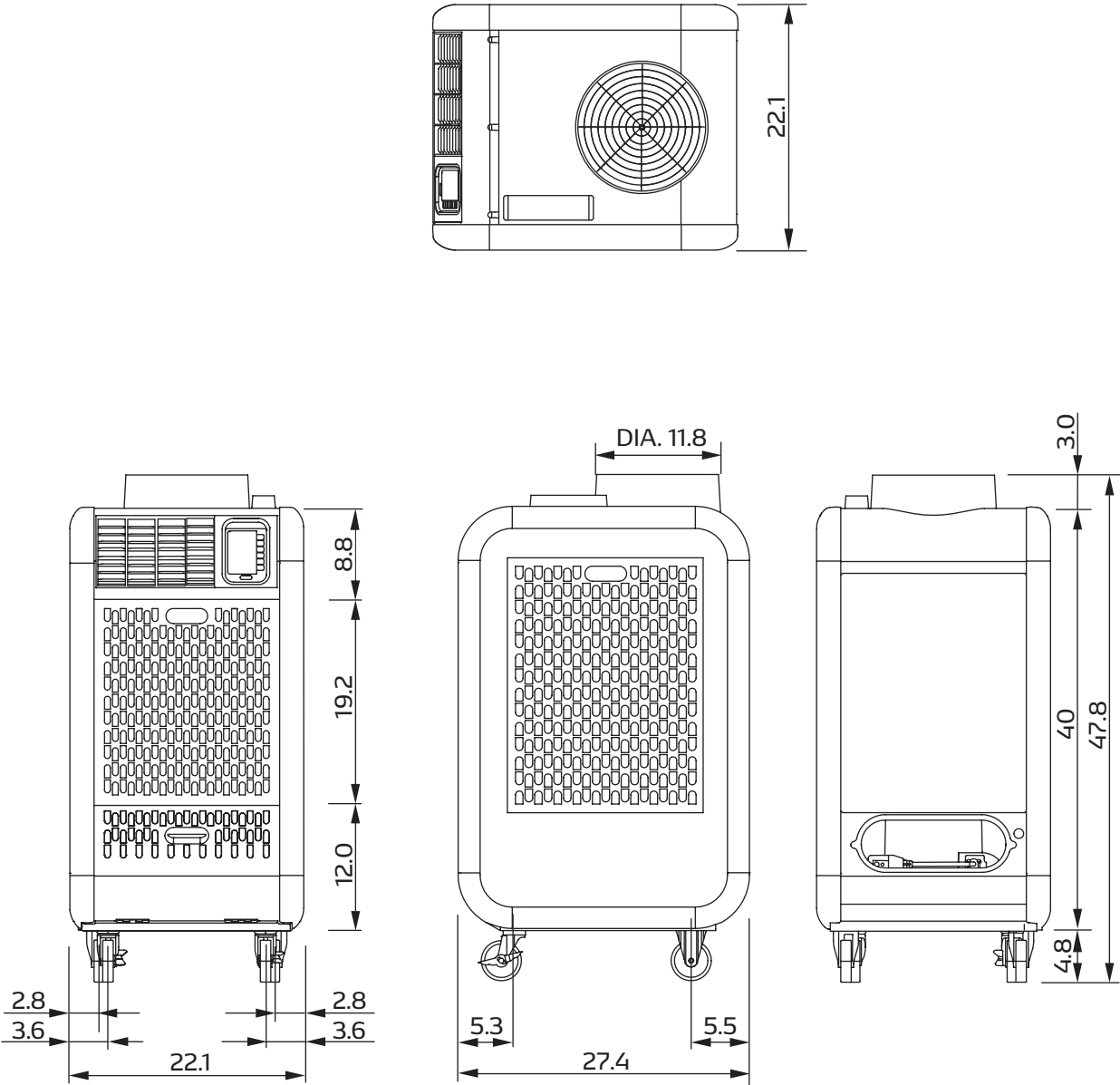

Unit: inch

Names of Parts

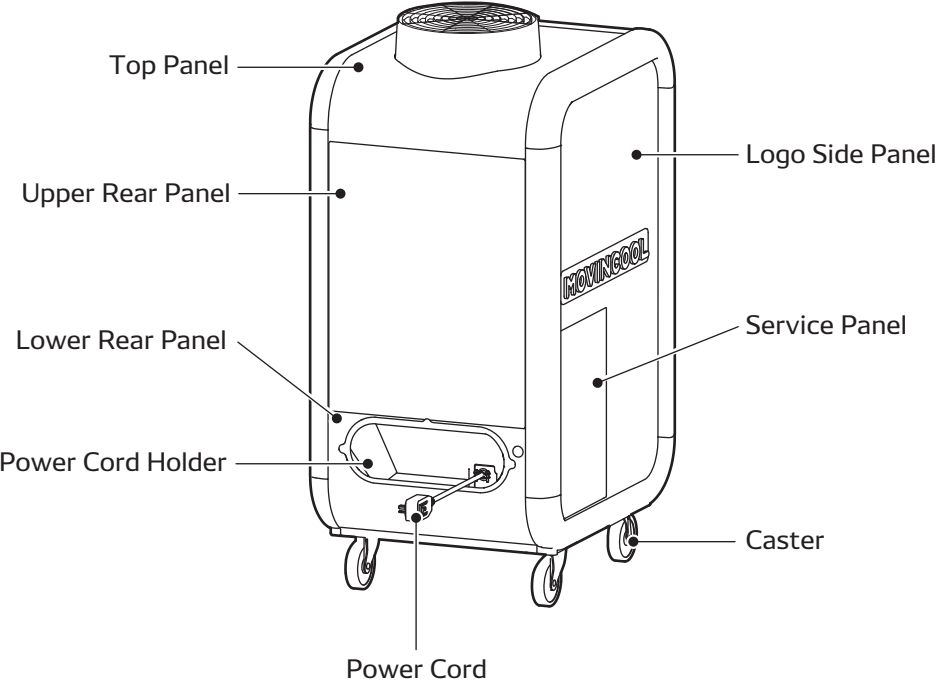
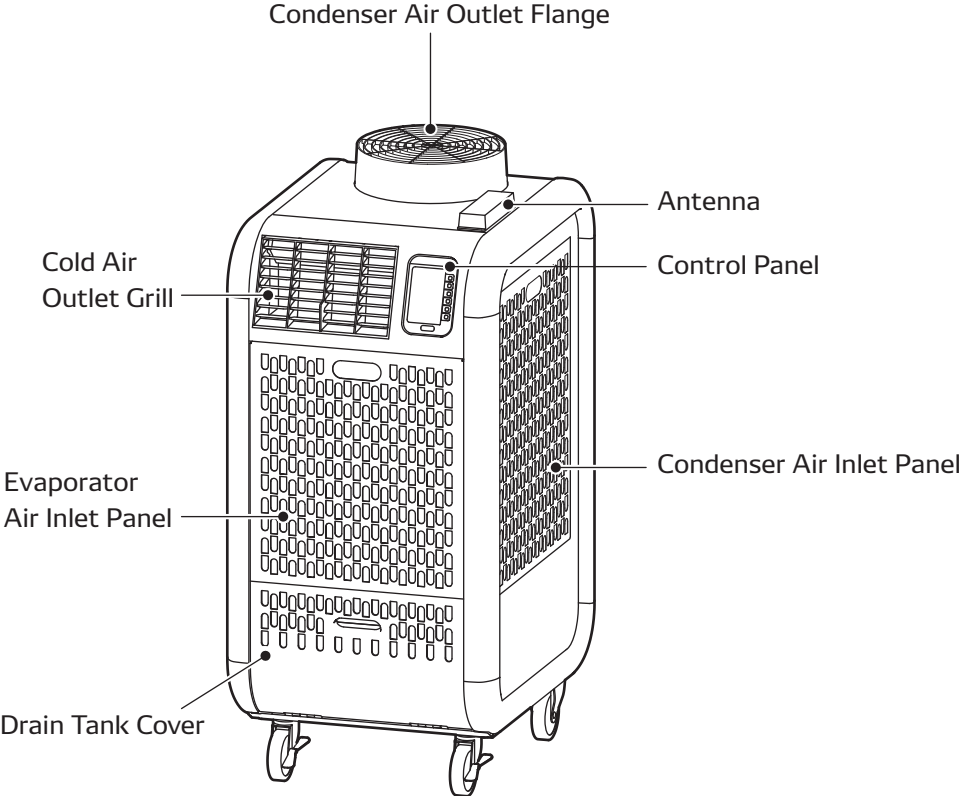

Internal Structure

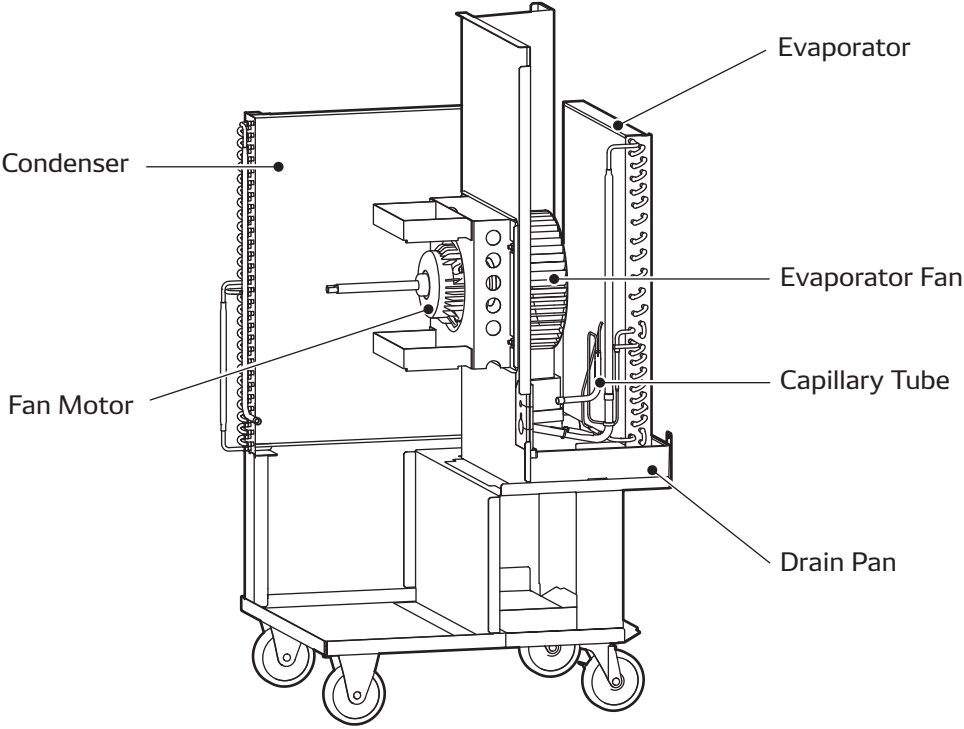
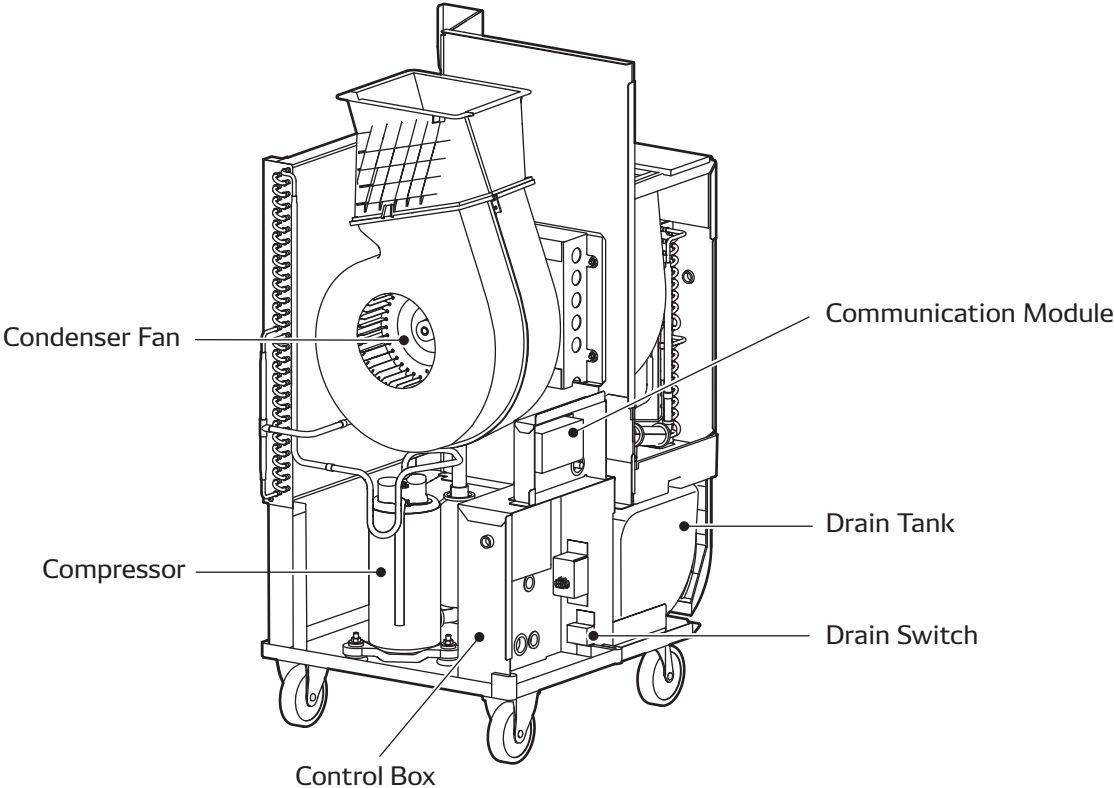

SPECIFICATIONS

Technical Specifications

	ITEM	SPECIFICATIONS
Electronic Features	Control	Programmable
Cooling Capacity *1	Total Capacity	16,800 Btu/h
Electrical Characteristics	Power Requirement	115V, 1Phase, 60Hz
	Total Power Consumption *1	1.7 kW
	Current Consumption *1	14.5 amps
	Starting Current	65 amps
	Recommended Fuse Size	20 amps
	Min. - Max. Voltage	104 -127
	Energy Efficiency Ratio (EER)	10
Fans	Motor Rated Output	0.23 kW
Evaporator	Fan Type	Centrifugal
	Max. Air Flow - high/mid/low	540/500/440 CFM
	Max. External Static Pressure	0.31 IWG
Condenser	Fan Type	Centrifugal
	Max. Air Flow - high/mid/low	770/710/630 CFM
	Max. External Static Pressure	0.23 IWG
Refrigerant Circuit	Compressor Type	Hermetic Rotary
	Compressor Motor Rated Output	0.9 kW
	Evaporator	Plate Fin
	Condenser	Plate Fin
	Refrigerant Control	Capillary Tube
	Max. Allowable Pressure - high/low	820/290
Refrigerant	Type	R-410A
	Amount	1.65 lb (0.75 kg)
Power Cord	NEMA Plug Configuration	5-20
	Gauge	12 AWG (3-core)
	Length	10 ft
Condensate Tank Capacity		5 ± 0.5 gal

Technical Specifications

	ITEM	SPECIFICATIONS
Safety Device	Internal Overload Relay for Compressor	320°F ± 9°F (160°C ± 5°C) 39.5 amps
	Anti-Freezing Thermostat for Evaporator	On: 60°F ± 1.8°F (16°C ± 1°C) Off: 27°F ± 1.8°F (-3°C ± 1°C)
Signal Connection	Fire Alarm Input	No voltage contact input Contact resistance: less than 100 ohm
	Warning Signal Output	2 amps at 30V (DC/AC) max. with resistive load
Appearance	Paint color	Black
	Dimensions - W x D x H	22 x 27 x 47 in
Net Weight		172 lb
Packaging	Dimensions - W x D x H	26 x 31 x 51 in
	Weight	209 lb
Operating Conditions	Min.	65°F (18°C), @ 50% RH
	Max.	95°F (35°C), @ 60% RH
Max. Sound Level *2	With Condenser Duct high/mid/low	63/61/59 dB(A)
	Without Condenser Duct high/mid/low	65/63/60 dB(A)
Max. Duct Equivalent Length	Per Cold Duct Hose	25 ft
	Hot Duct Hose	60 ft
Operating Environment		Indoor
IP Number		IPX1
Design Lifetime of Product *3		7 years or 17,500 hours, whichever is shorter

Specifications are subject to change without notice.

*1: Rating condition: 95°F (35°C) at 60% RH

*2: Measured at 3 ft (1.0m) from surface of the unit

*3: 17,500 hours: (10 hours/day x 250 days) x 7 years

Characteristics

<Cooling Capacity Curve>

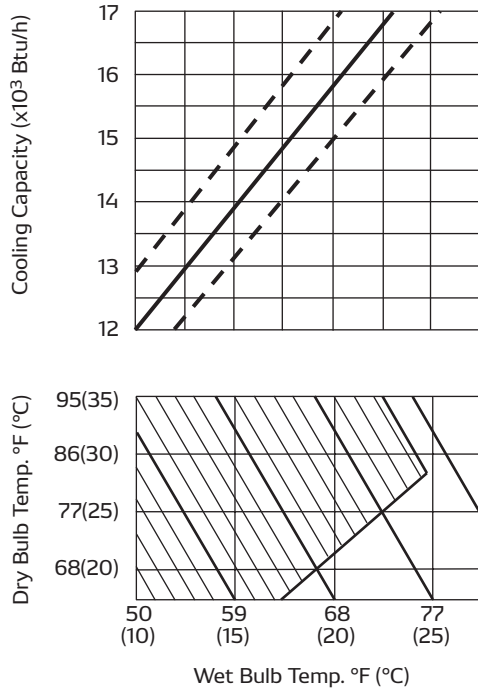

<Cool Air Temperature Difference Curve>

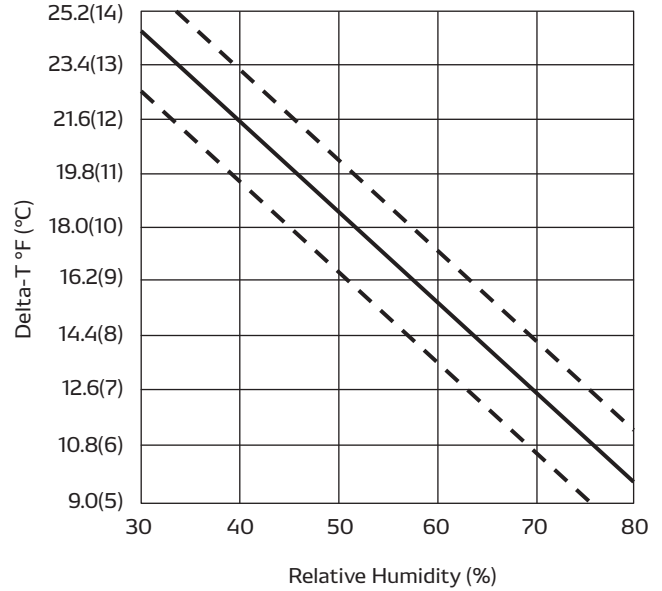

<Power Consumption Curve>

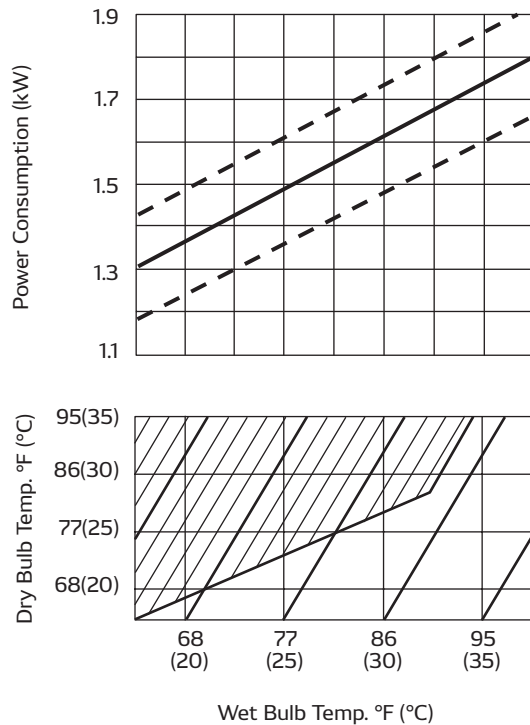

<Current Consumption Curve>

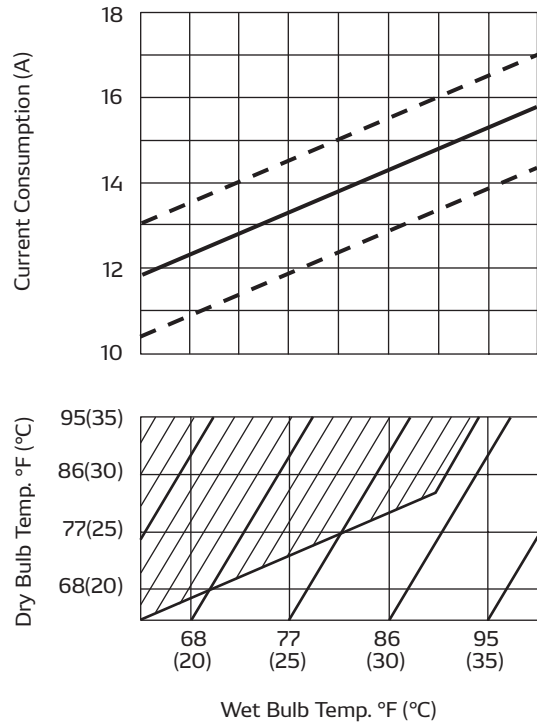

SERVICE INFORMATION

Machine Status

The status of functional parts can be displayed while the unit is running.

HOME > MENU > SERVICES > MACHINE INFORMATION > MACHINE STATUS

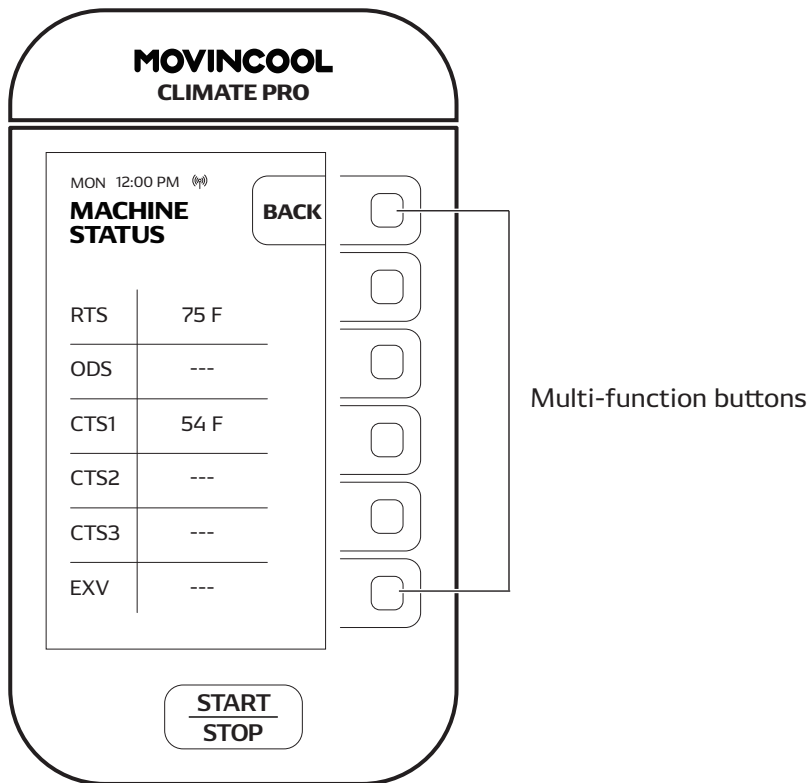

CODE	ITEM	UNIT
RTS	Evaporator air inlet thermistor temperature	°F/°C
ODS	Condenser air inlet thermistor temperature	°F/°C
CTS1	Evaporator pipe thermistor temperature	°F/°C
CTS2	Compressor pipe thermistor temperature	°F/°C
CTS3	Condenser pipe thermistor temperature	°F/°C
EXV	Electronic expansion valve opening	-

Note:

- If you need to change temperature scale, go to HOME > MENU > SETTING > TEMP SCALE.

Machine Records

The history of connection time, compressor operating time, defrosting time, fan operating time, and self-diagnostic codes are displayed while the unit is running.

HOME > MENU > SERVICES > MACHINE INFORMATION > MACHINE RECORDS

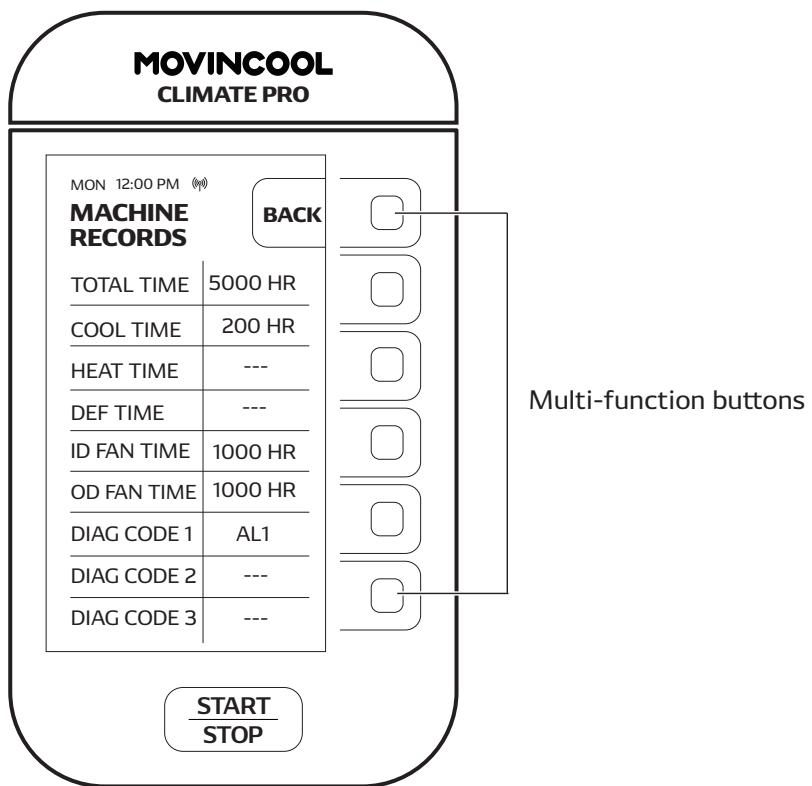

DISPLAY ITEM	DESCRIPTION	UNIT
TOTAL TIME	Total connection time	hour
COOL TIME	Total compressor operating time during cool mode	hour
HEAT TIME	Total compressor operating time during heat mode	hour
DEF TIME	Total defrosting time during heat mode	hour
ID FAN TIME	Total evaporator fan operating time	hour
OD FAN TIME	Total condenser fan operating time	hour
DIAG CODE 1	Self-diagnostic code 1: Latest code	AL1 (example)
DIAG CODE 2	Self-diagnostic code 2: Previous code before the DIAGNOSTIC CODE 1	AS (example)
DIAG CODE 2	Self-diagnostic code 3: Previous code before the DIAGNOSTIC CODE 1 and 2	HP (example)

- Up to 65,500 hours can be stored before being cleared and reset to zero.
- Up to 3 different recorded self-diagnostic codes are displayed.

Note:

- If the item is not applicable for the unit, " --- " is displayed.

TROUBLESHOOTING

Initial Inspection

Before troubleshooting, the following inspection should be performed.

1. Check the voltage of the power source.
115 V, 1 Phase, 60 Hz
2. Check the operation and condition of the fuse or circuit breaker in the power source.
3. Check the power cord. If dirty, wipe with a clean dry cloth. If damage or excess play is found, replace the cord.
4. Check the air filters. If dirty, clean the air filters as described in the operation manual. If damage is found, replace the filters.
5. Check the drain tank and empty the water. If damage is found, replace the tank.



WARNING

- **Disconnect power supply from the unit before performing any service. Beware that some residual voltage may remain in the unit immediately after the power is disconnected. There is a risk of electric shock.**

Self-Diagnostic Codes

When a self-diagnostic code is displayed on the LCD, the unit stops operation, relay contact RL07 for terminal OS-1 and OS2 is closed.

CODE	CONDITION	POSSIBLE CAUSE	SOLUTION
AL1	Alarm device 1 is activated	Alarm device connected to FA-1 and FA-2 of terminal block 1 is activated	<ol style="list-style-type: none"> 1. Check FA-1, FA-2 connection 2. Identify and correct condition causing alarm 3. Press CLEAR button to reset
AL2	Alarm device 2 is activated	Alarm device connected to AL-1 and AL-2 of terminal block 1 is activated	<ol style="list-style-type: none"> 1. Check AL-1, AL-2 connection 2. Identify and correct condition causing alarm 3. Press CLEAR button to reset
FL	Drain tank is full	Drain tank is full of water	<ol style="list-style-type: none"> 1. Empty tank 2. Place tank back in unit 3. Press CLEAR button to reset
		Loose drain switch connection	<ol style="list-style-type: none"> 1. Reconnect switch 2. Press CLEAR button to reset
		Defective drain switch	<ol style="list-style-type: none"> 1. Replace switch 2. Press CLEAR button to reset
PU	Condensate pump safety switch is activated	Condensate pump stops due to kinks and/or blockage or improper routing of drain line	<ol style="list-style-type: none"> 1. Remove blockage or kinks from drain line, or re-route drain line 2. Press CLEAR button to reset
		Missing or loose jumper connector	<ol style="list-style-type: none"> 1. If the jumper connector is missing, insert one If connector is loose, reconnect it 2. Press CLEAR button to reset
		Defective condensate pump	<ol style="list-style-type: none"> 1. Replace pump 2. Press CLEAR button to reset
CF	Cooling function failure occurs 3 times and following condition continues for 15 minutes RTS - CTS1 < 9 °F (5 °C)	Insufficient refrigerant or refrigerant leak	Repair leak and add refrigerant based on the weight listed on specifications or nameplate
		Defective compressor	<ol style="list-style-type: none"> 1. Replace compressor 2. Press CLEAR button to reset
E1	RTS thermistor failure	Loose RTS thermistor connection	Reconnect thermistor
		Defective RTS thermistor (short or open circuit)	Replace thermistor
E3	CTS1 thermistor failure	Loose CTS1 thermistor connection	Reconnect thermistor
		Defective CTS1 thermistor (short or open circuit)	Replace thermistor

Troubleshooting Chart

PROBLEM		POSSIBLE CAUSE	SOLUTION
Unit does not operate	No display on LCD screen	Power failure	Check and fix power supply and connection
		Ground fault protective breaker is tripped	Reset breaker
		Defective ground fault protective breaker	Repair or replace breaker
		LCDI Power cord is tripped	Reset power cord
		LCDI Power cord is damaged	Replace power cord
LCD display is normal, but unit does not start	Ambient temperature has reached set temperature and unit has stopped	Adjust set temperature	
Unit stops immediately after starting	LCD display is normal	Fan motor malfunction See "Inspection of Parts" on page 41	Replace fan motor
		Compressor malfunction See "Inspection of Parts" on page 42	Replace compressor
		If fan motor and compressor are normal, there is a problem with relay board	Replace relay board
Unit stops after running for a while	LCD display is normal	Operating near minimum or maximum of operating temperature range	Review room environment
		Dirt in indoor or outdoor heat exchanger	Clean heat exchanger
		Insufficient refrigerant or refrigerant leak	Repair leak and add refrigerant based on the weight listed on specifications or nameplate

Troubleshooting Chart

PROBLEM			POSSIBLE CAUSE	SOLUTION
Poor cooling performance	Air volume normal	Compressor operates	Operating near minimum or maximum of operating temperature range	Review room environment
			Dirt in indoor or outdoor heat exchanger	Clean heat exchanger
			Frosting on the refrigerant line caused due to blockage	Service refrigeration system
			Insufficient refrigerant	Check for leaks, repair, and add refrigerant based on the weight listed on specifications or nameplate
Poor cooling performance	Air volume normal	Compressor does not operate	Low voltage	Repair power supply
			Capacitor malfunction See "Inspection of Parts" on page 40	Replace capacitor
			Resistance of compressor coil is zero or infinity due to a short or open circuit	Replace compressor
			If power supply, capacitor and compressor are normal, there is a problem with relay board	Replace relay board
	No air		Fan motor malfunction See "Inspection of Parts" on page 41	Replace fan motor
			If fan motor is normal, there is a problem with relay board	Replace relay board
	Air volume abnormal	Air volume insufficient	Clogged air filter	Clean air filter
			Clogged indoor or outdoor heat exchanger	Clean heat exchanger
			Crushed fins	Repair or replace heat exchanger
			Improper duct connection (Optional accessories)	Adjust duct connection
Abnormal rotation of indoor or outdoor fan motor			Replace fan motor	

Troubleshooting Chart

PROBLEM	POSSIBLE CAUSE	SOLUTION
Water leaking from unit	Cracks in drain pan	Replace drain pan
	Drain hose is blocked or damaged (Optional drain pump)	Unblock or repair drain hose
	Reversed air flow from drain hole due to excessive negative pressure inside of unit	Clean air filters
Abnormal noise or vibration	Fan interference	Adjust interfering section
	Fan deformation	Replace fan
	Loose compressor nuts	Tighten nuts
	Pipe interference	Adjust pipe
	Loose panel screws	Tighten screws
Communication module not working properly	"P" LED indicator on communication module is off due to AC power is not plug in and communication module battery switch at the OFF position	Plug in AC power or set communication module battery switch to ON position
	When the "L" LED indicator located on the communication module is off, it may be due to poor or no cellular (LTE) signal, connection or unit is located in an area with high signal interference or an area that restricts LTE signal	RESET communication module
	When the "G" LED indicator located on the communication module is off, it may be due to poor or no navigation (GNSS) signal, connection or unit is located in an area with high signal interference or an area that restricts GNSS signal	To reset, press reset button and confirm "P" LED indicator blinks one time and stays on

Inspection Before Disassembly

1. Inspection of plate fins on heat exchangers

Remove air filters and check plate fins for any dirt, dust, lint, or debris that may cause insufficient cooling performance. If necessary, clean the plate fins.

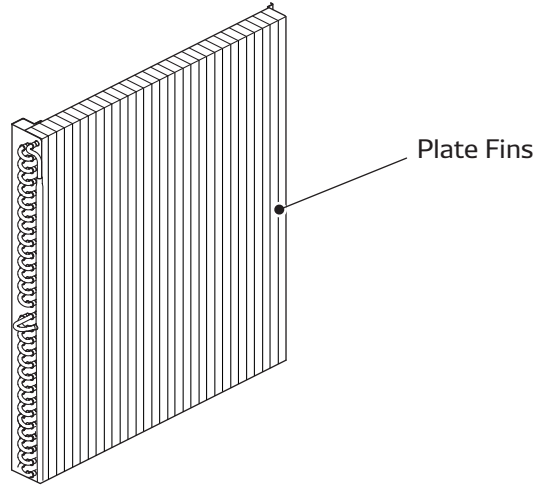

2. Inspection of cooling capacity performance

Measure the difference in air temperature between the inlet of the evaporator and the cool air vent. If the difference is out of the range of the graph on page 12, proceed with the solution of "Poor cooling performance" on page 18.

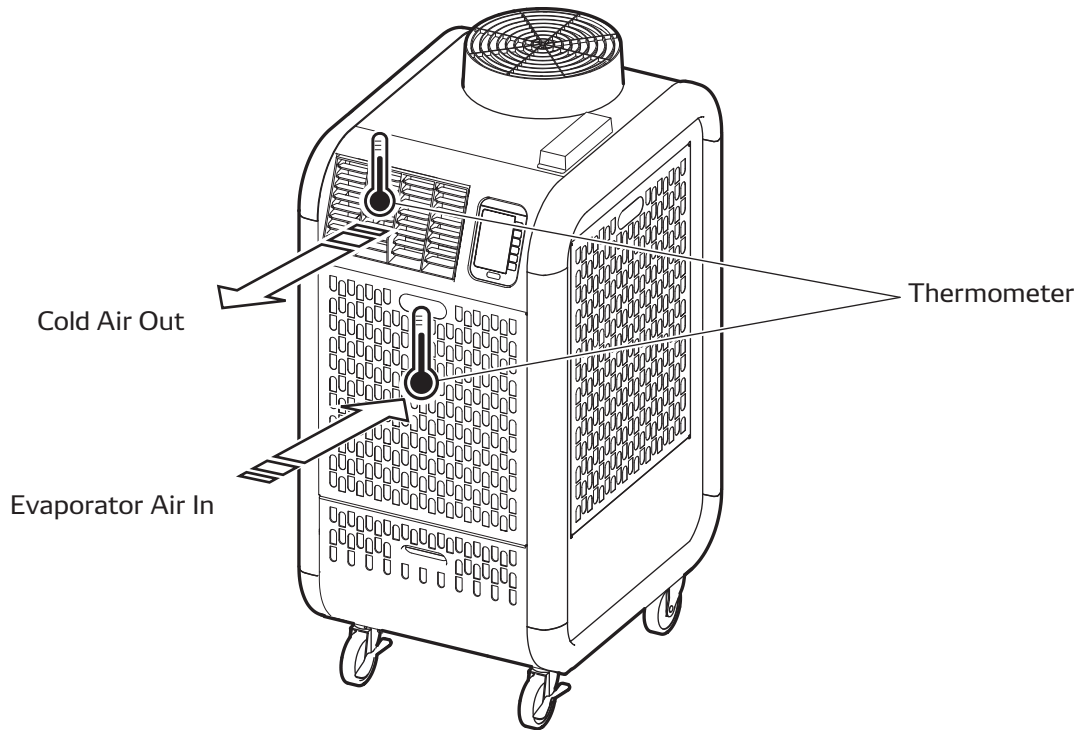

DISASSEMBLY

WARNING

- Electrical work must be performed by qualified electrical personnel. Failure to use qualified electrical personnel for electrical work may cause fire, electric shock, injury, malfunction or water leaks.
- Use genuine MovinCool parts for servicing. Non-genuine parts may cause fire, electric shock or water leaks.
- Disconnect power supply from the unit before performing any service. Beware that some residual voltage may remain in the unit immediately after the power is disconnected. There is a risk of electric shock.

Structure Parts

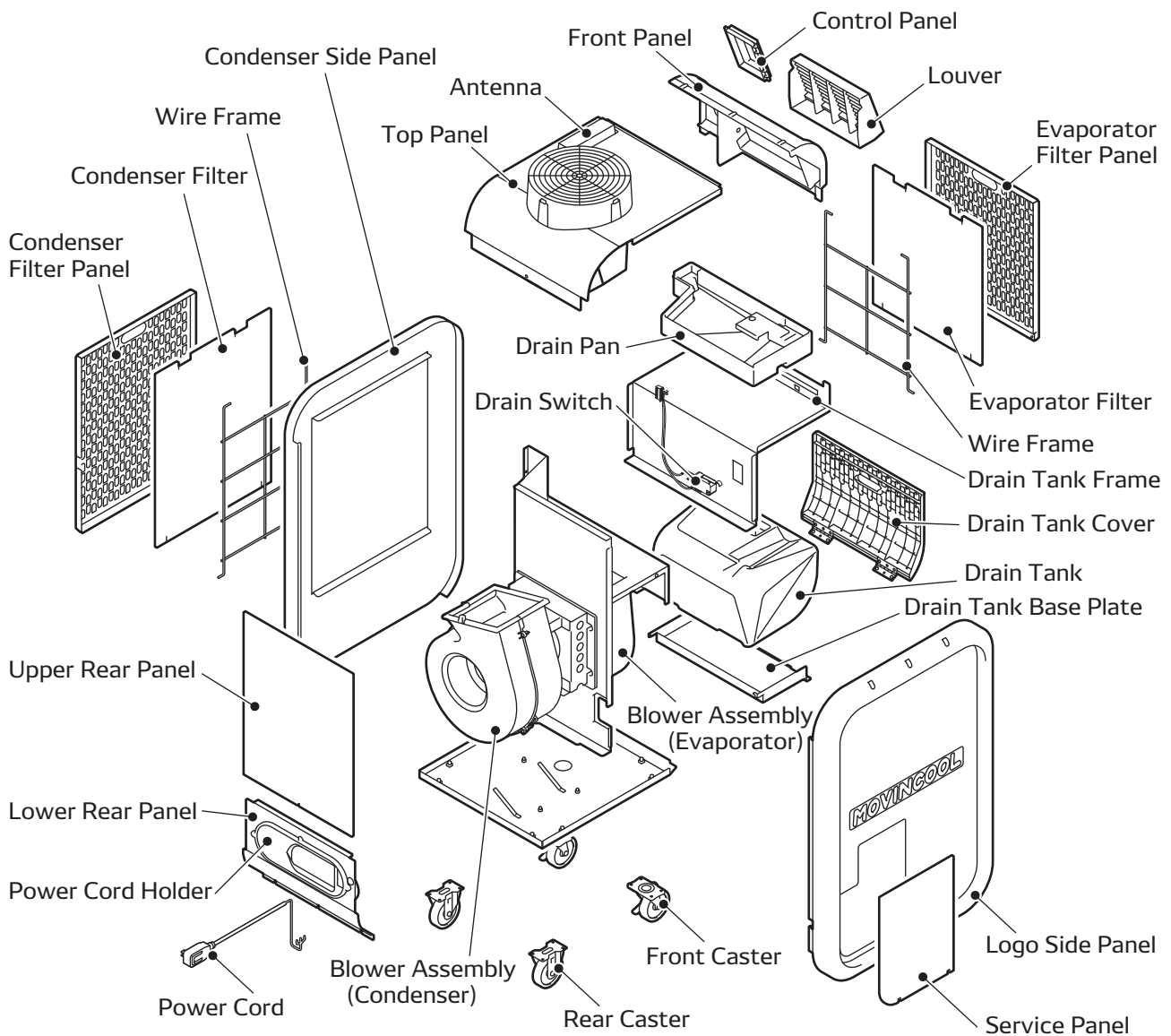

Removal of Panels

1. Open the drain tank cover and remove the tank.

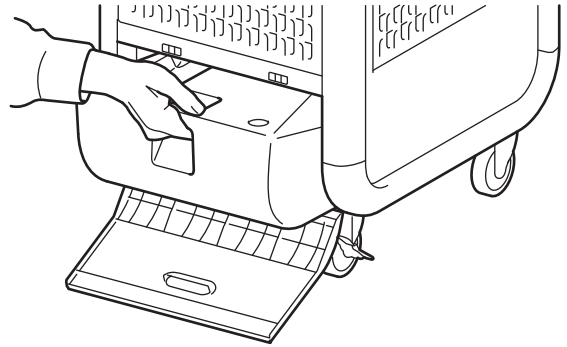

2. Remove the evaporator and condenser filter panels.

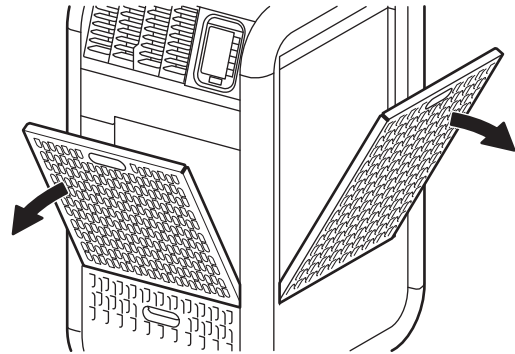

3. Loosen the bottom two (2) screws and remove the other seven (7) M4 x L10 screws. Move the service panel upward and remove it from the logo side panel.

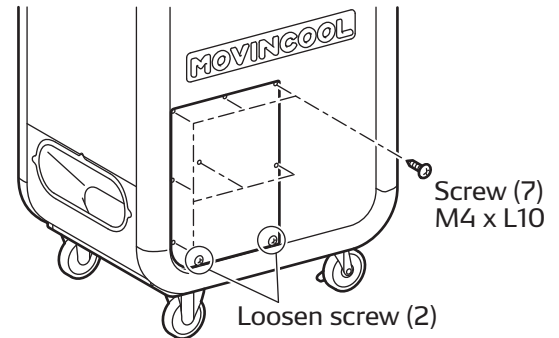

4. Loosen the center bottom screw (1) and remove the other seven (7) M4 x L10 screws. Move the upper rear panel upward and remove it.

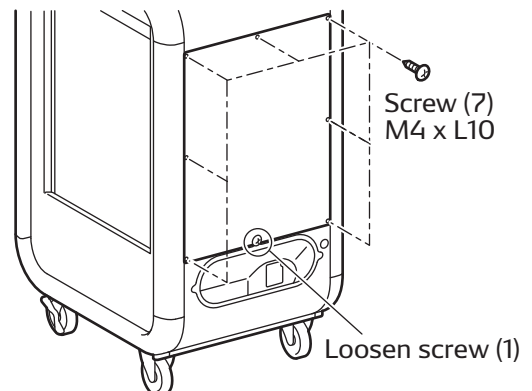

Removal of Panels

5. Power cord holder can be removed from the lower rear panel. Remove the four (4) M4 x L10 screws and remove the power cord holder.

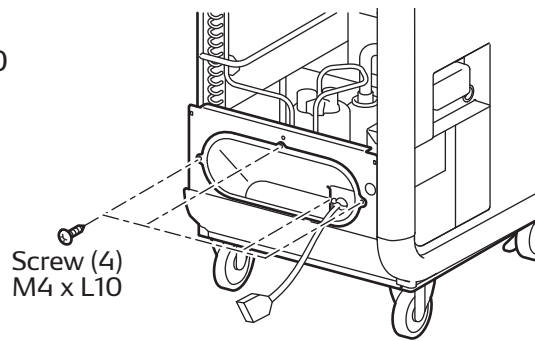

6. Remove the ten (10) M4 x L10 screws and one (1) M4 x L12 screw. Next remove the logo side panel.

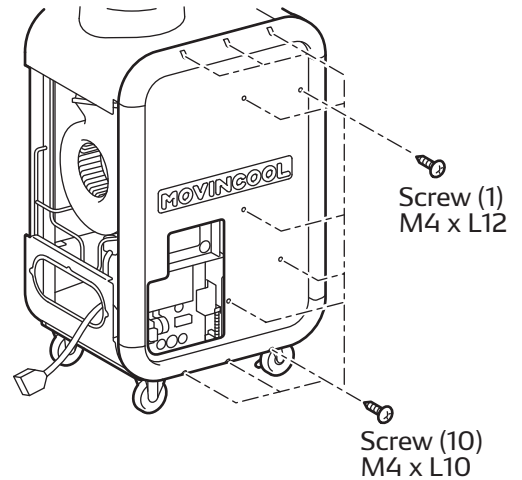

7. Remove the fifteen (15) M4 x L10 screws and one (1) M4 x L12 screw. Next remove the condenser side panel.

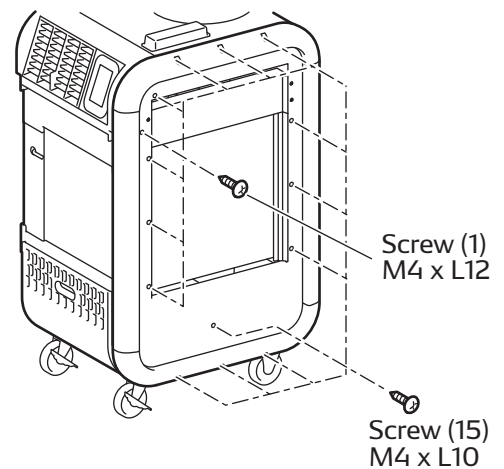

8. Disconnect the CN1 and CN2 connectors from the control board.

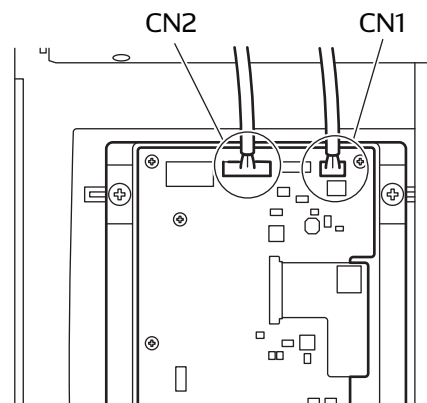

Removal of Panels

9. Remove the five (5) M4 x L10 screws and remove the upper front panel.

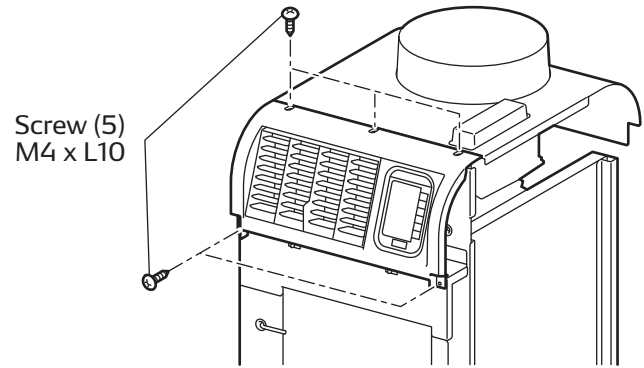

10. Remove the four (4) wires of the antenna from the communication module in the control box.

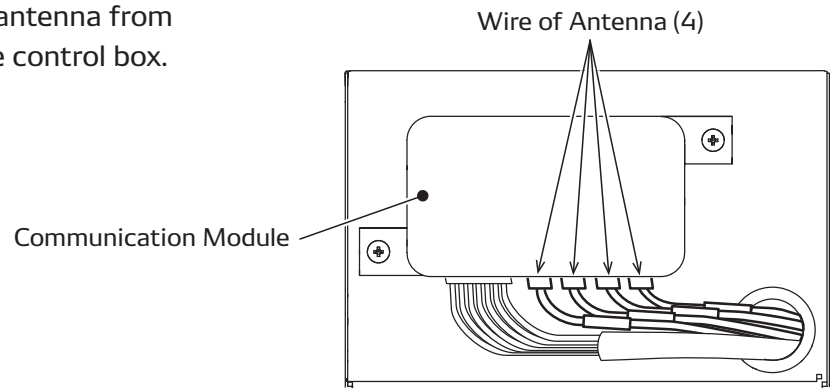

11. Remove the two (2) M4 x L10 screws from the top panel and remove the one (1) M4 x L14 screw from the condenser fan casing. Next remove the top panel.

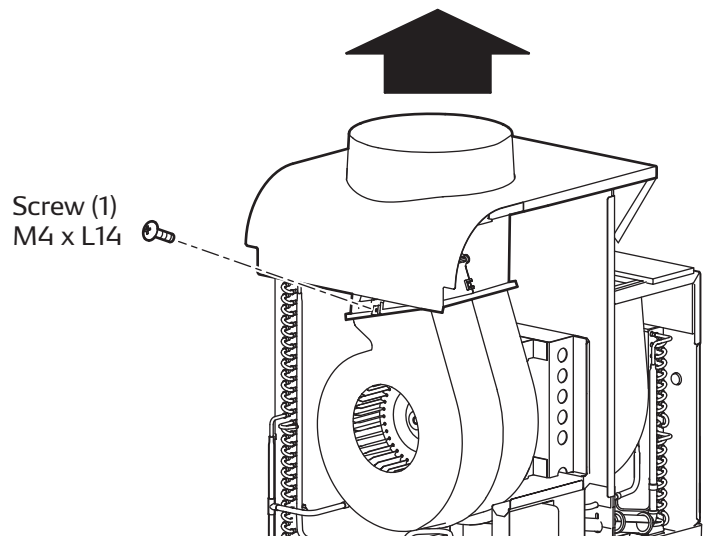
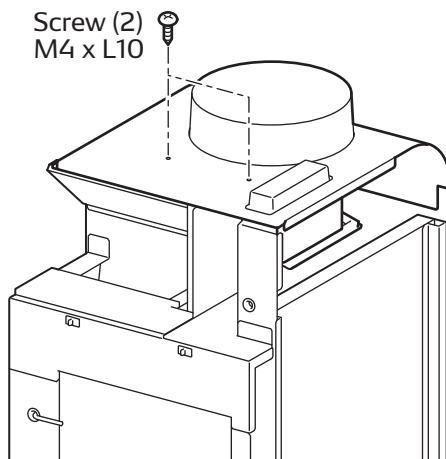

Removal of Louver

Louver can be removed from the upper front panel by releasing either of the lock tabs from notches.

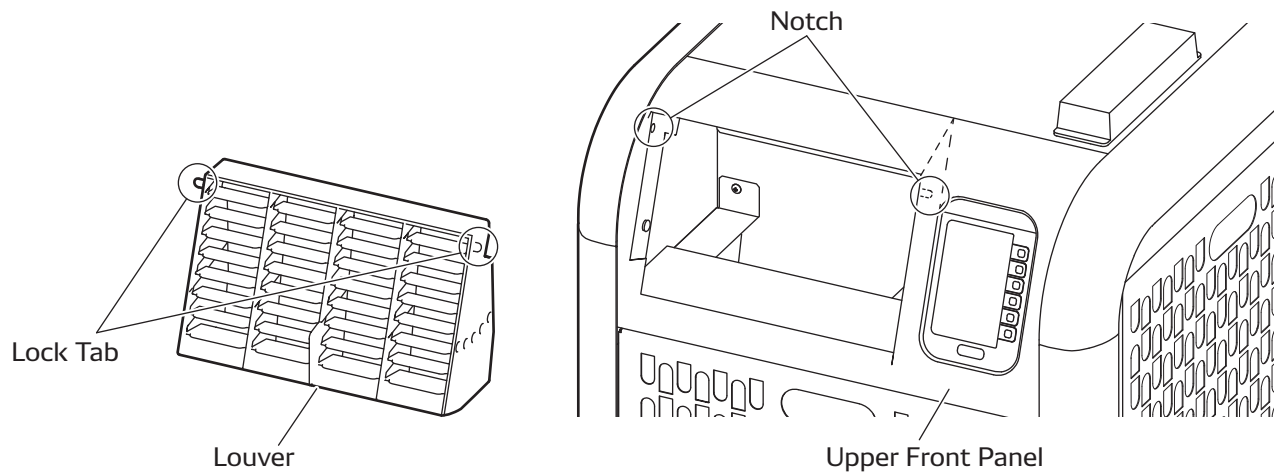

1. Lift the bottom of the louver upward.

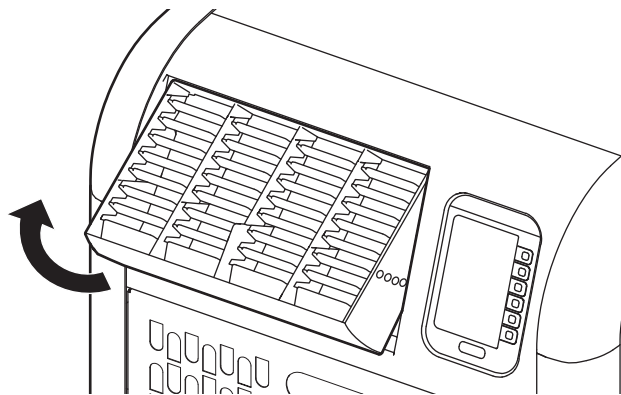

2. Slide the louver a little to the right or left so as to release the lock tab from the notch and pull out the louver.

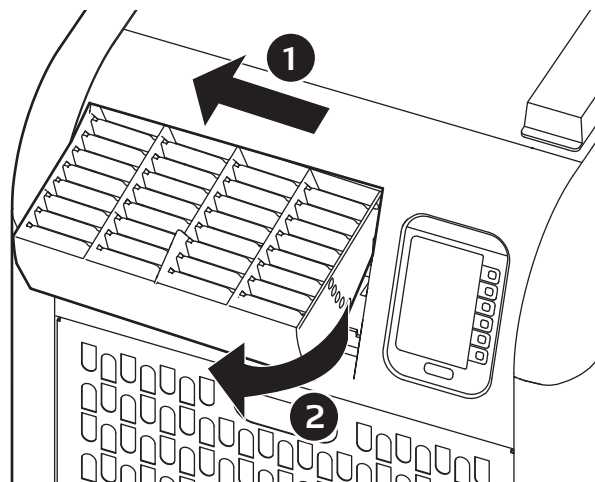

Removal of Bumpers

Logo side panel

1. Remove the five (5) M4 x L12 screws and remove the bumper **A**
2. Remove the five (5) M4 x L12 screws and remove the bumper **B**
3. Remove the five (5) M4 x L12 screws and remove the bumper **C**
4. Remove the three (3) M4 x L12 screws and remove the bumper **D**

Note:

- To remove bumper **C** or **D**, bumper **A** and **B** should be removed first.

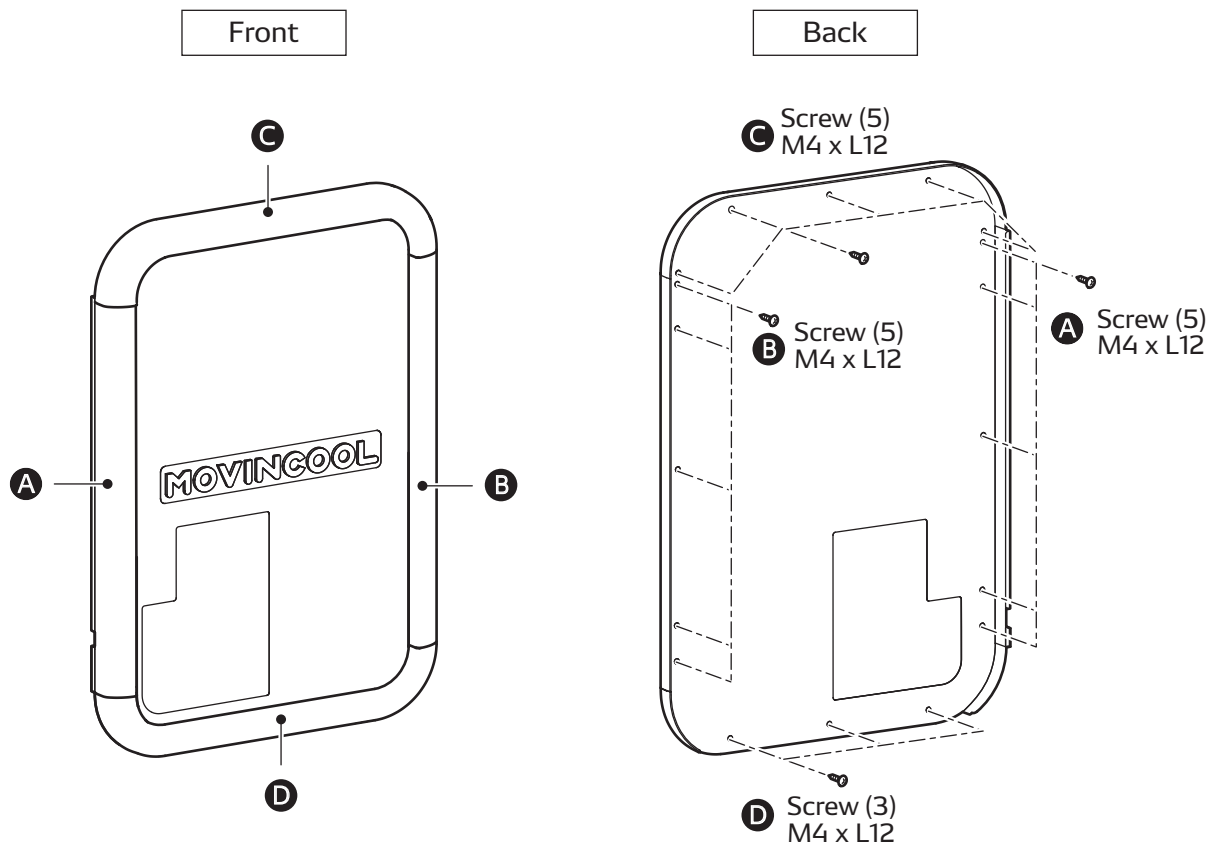

Removal of Bumpers

Condenser side panel

1. Remove the five (5) M4 x L12 screws and remove the bumper **A**
2. Remove the five (5) M4 x L12 screws and remove the bumper **B**
3. Remove the five (5) M4 x L12 screws and remove the bumper **C**
4. Remove the three (3) M4 x L12 screws and remove the bumper **D**

Note:

- To remove bumper **C** or **D**, bumper **A** and **B** should be removed first.

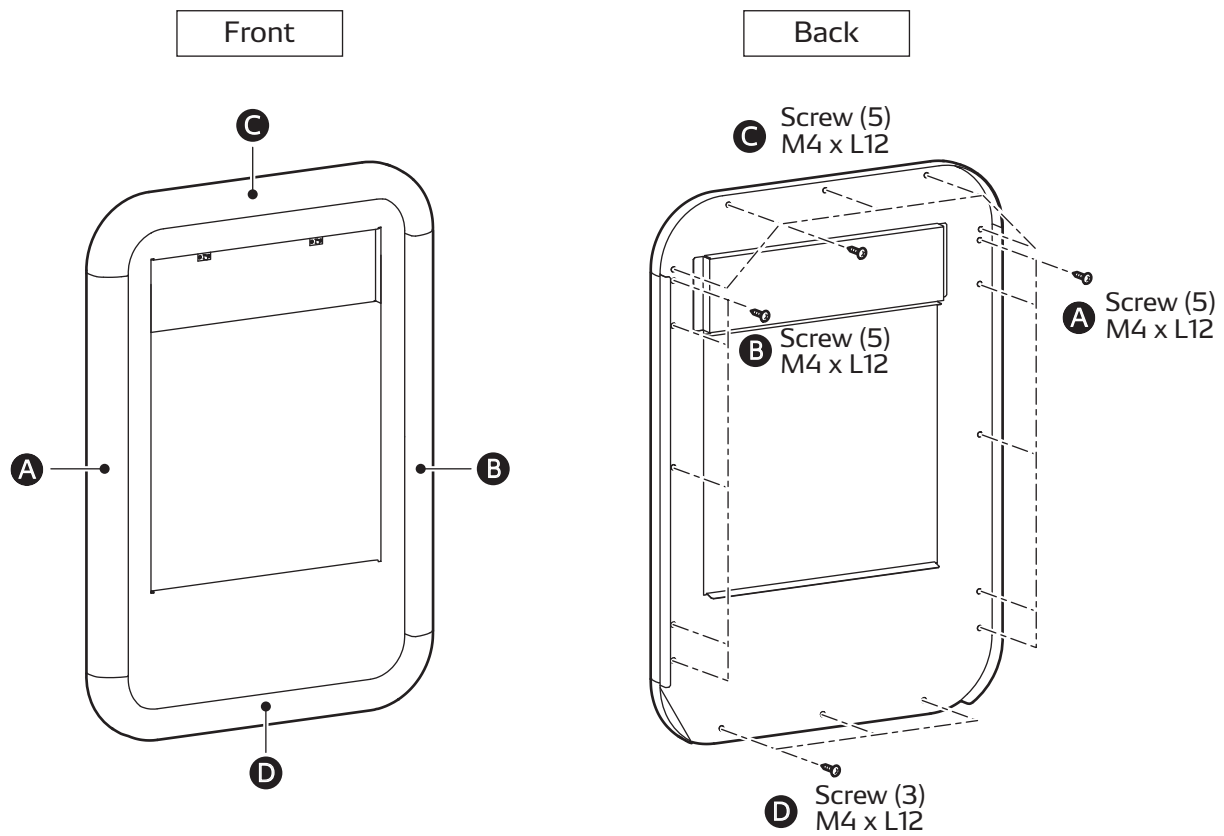

Removal of Electrical Parts

1. Control box

- a) Remove the service panel from the logo side panel. (See step 3 on page 22)
- b) Remove the following number of screws and remove each electrical part from the control box.

- Communication module: two (2) screws
- Terminal block 1: two (2) screws
- Terminal block 2: two (2) screws
- Compressor motor capacitor: one (1) screw
- Drain switch: two (2) screws

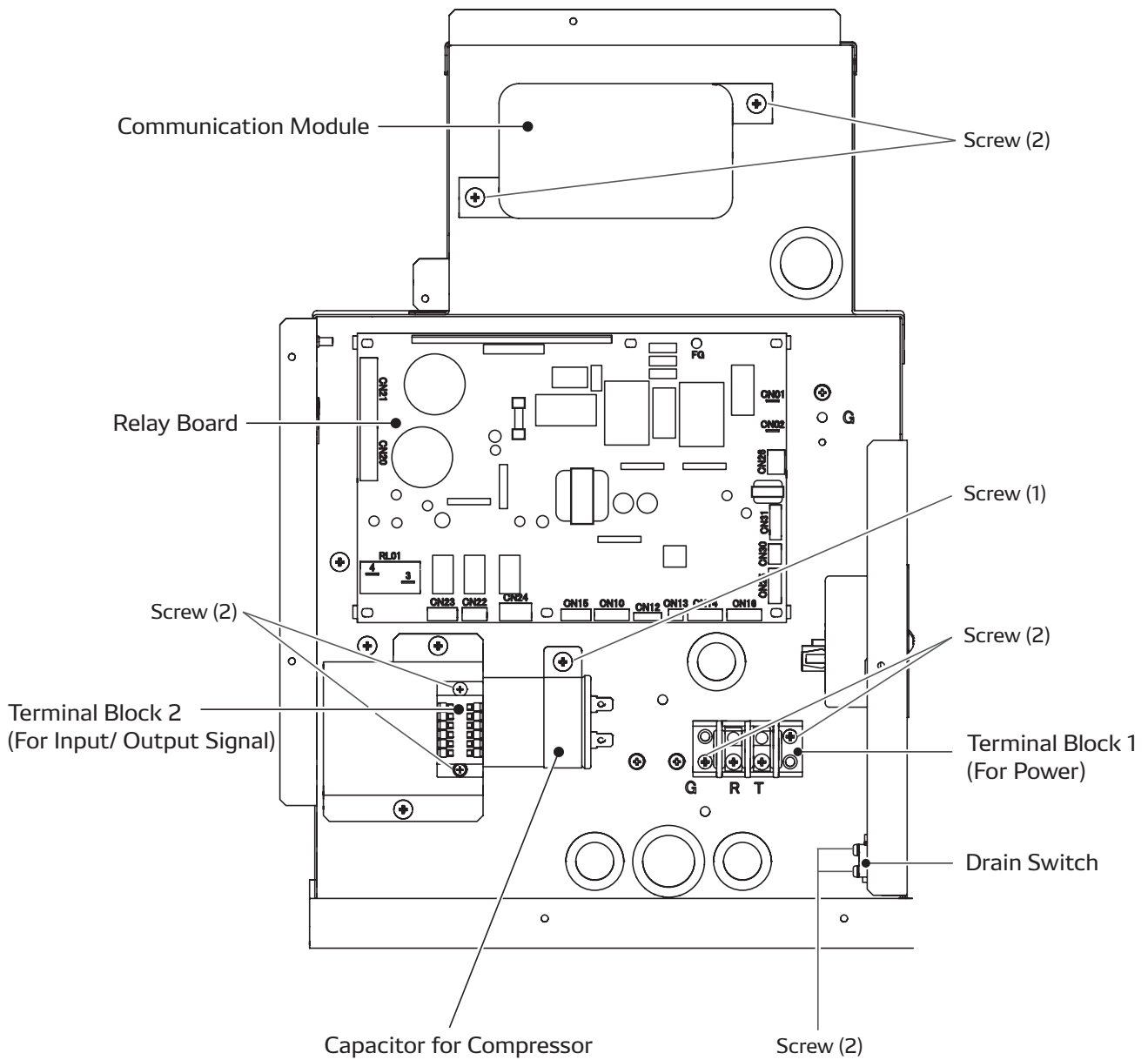

Removal of Electrical Parts

2. Relay Board

- a) Remove the six (6) supports with needle-nose pliers and remove relay board from the control box.

Note:

- Be careful not to damage the relay board.
- b) Disconnect the ten (10) connectors from the relay board.

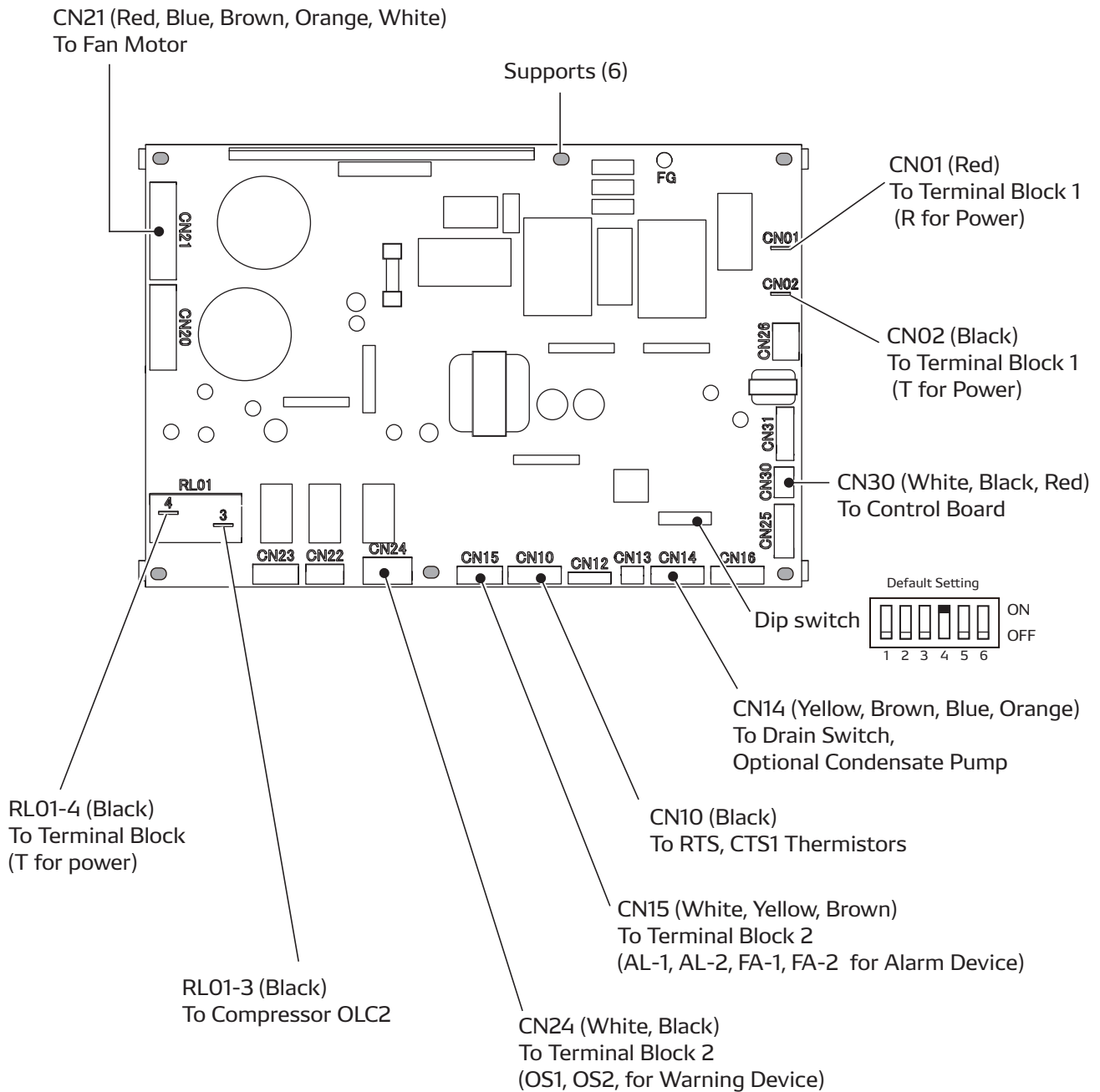

Removal of Electrical Parts

3. Control Panel (see "Removal of Panels")
 - a) Follow step 2, 3, 4, 6, and 7 in "Removal of Panels" section.
 - b) Disconnect the CN1 and CN2 connectors from the control board.

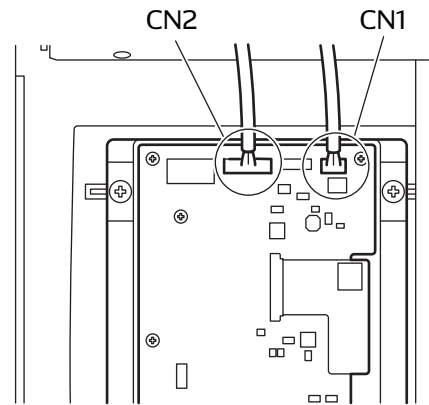

- c) Remove the five (5) M4 x L10 screws and remove the upper front panel.

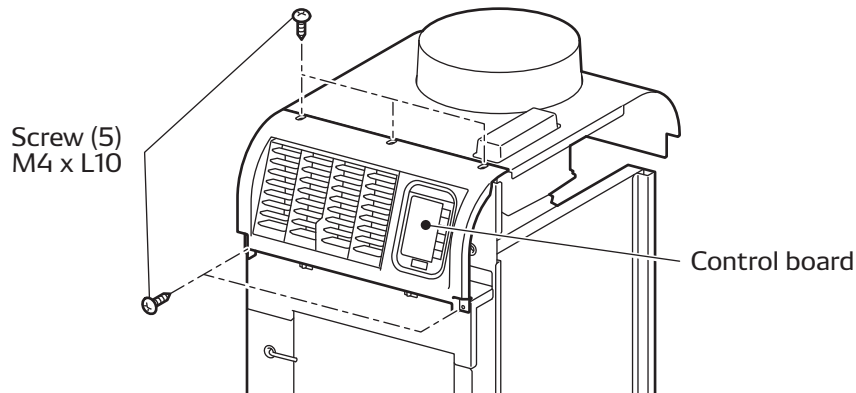

- d) Remove the four (4) M4 x L12 screws and remove the control panel from the upper front panel.

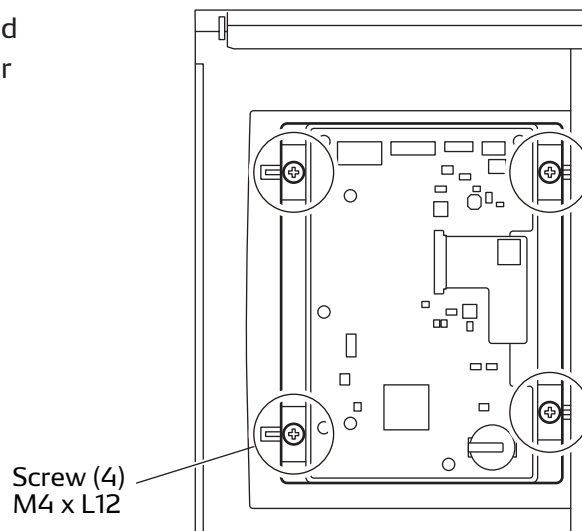

Removal of Antenna

1. Follow step 2, 3, 4, and 7 in "Removal of Panels" section.
2. Remove the four (4) wires of the antenna from the communication module in the control box.

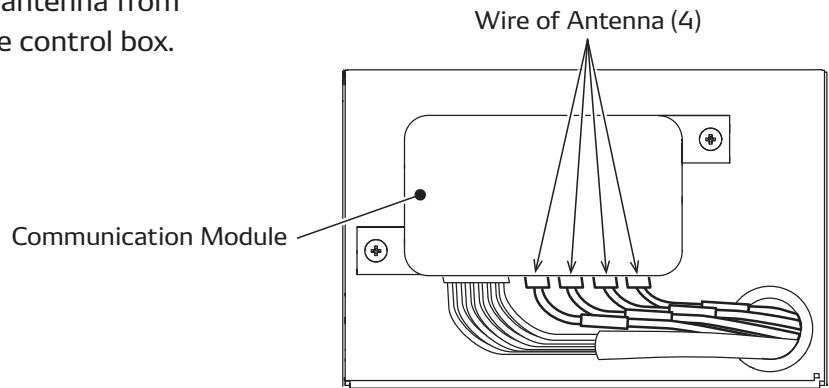

3. Remove the two (2) M4 x L10 screws from underneath the top panel to detach antenna from the top panel.

Note:

- Do not try to remove antenna wires from the antenna housing, this may cause damage to the antenna module.

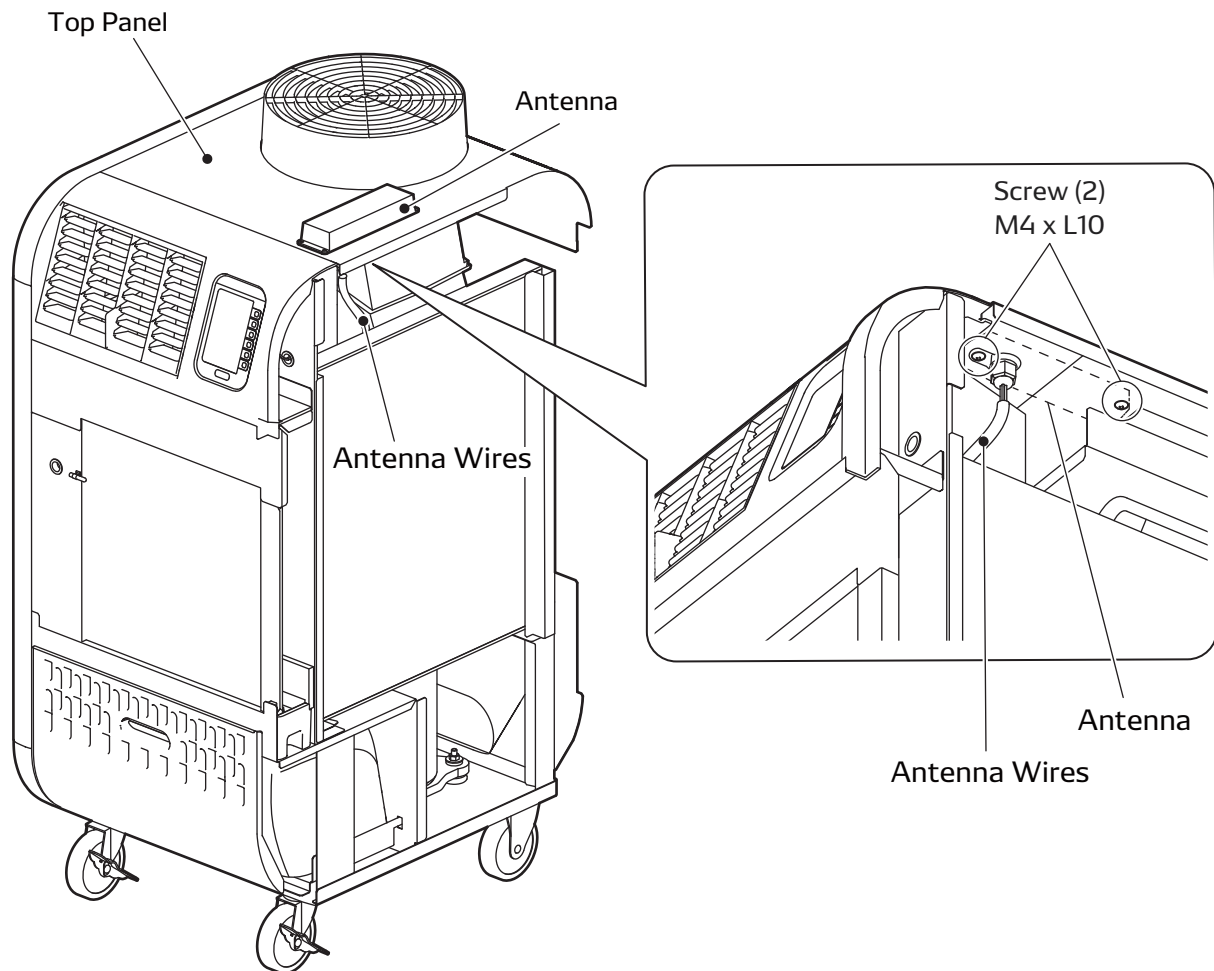

Removal of Communication Module

Communication Module Hardware Description

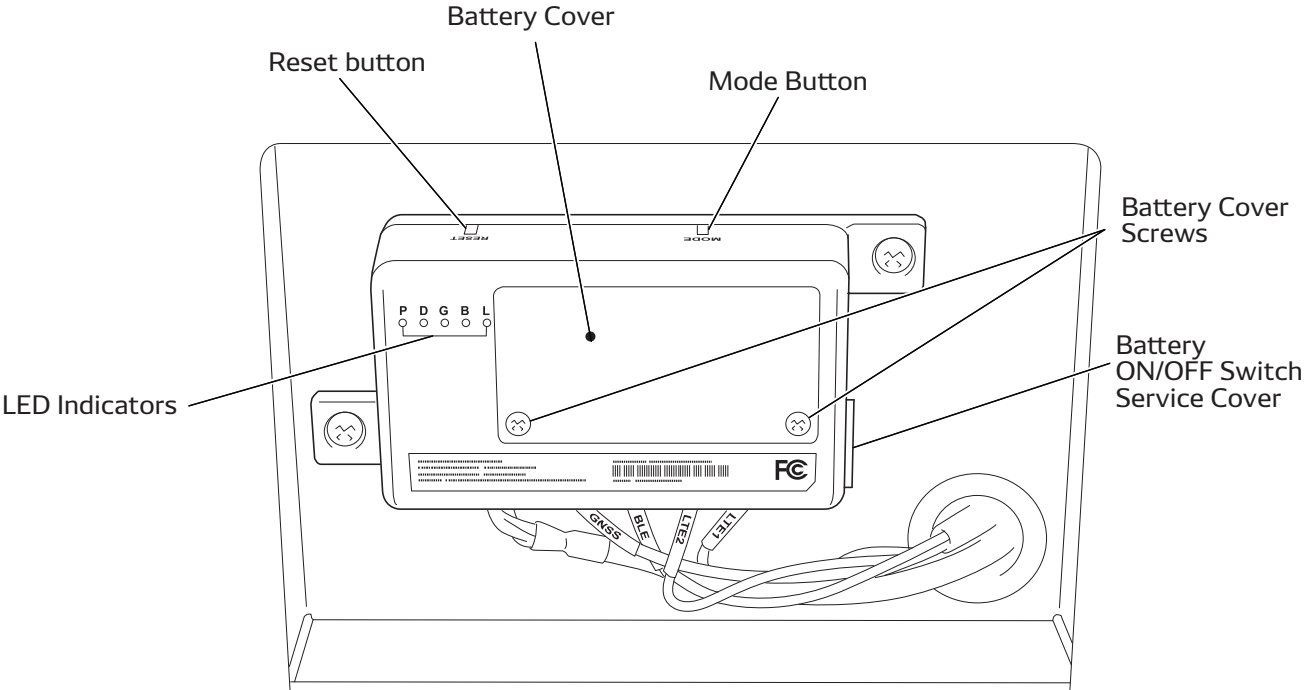

Removal of Communication Module

Table of LED Indication

LABEL	NAME	COLOR	LED "ON"	LED "OFF"	LED BLINKING
P	Power LED	Red	Working	Sleeping	Error
D	Device LED	Orange	In Inspection Mode*	NOT in Inspection Mode	Receiving data via DEVICE I/F Port
G	GNSS LED	Blue	GNSS Fixed (Location data is acquired)	GNSS Not Fixed (Location data is NOT acquired)	- (G LED does not blink)
B	BLE LED	Orange	Connected to BLE gateway	Disconnected to BLE gateway	- (B LED does not blink)
L	LTE LED	Orange	Connected to LTE network	Disconnected to LTE network	- (L LED does not blink)

*Inspection mode is for internal use

1. Disconnect the following cable connectors:

- I/F connector
- GNSS connector
- BLE connector
- LTE2 connector
- LTE1 connector

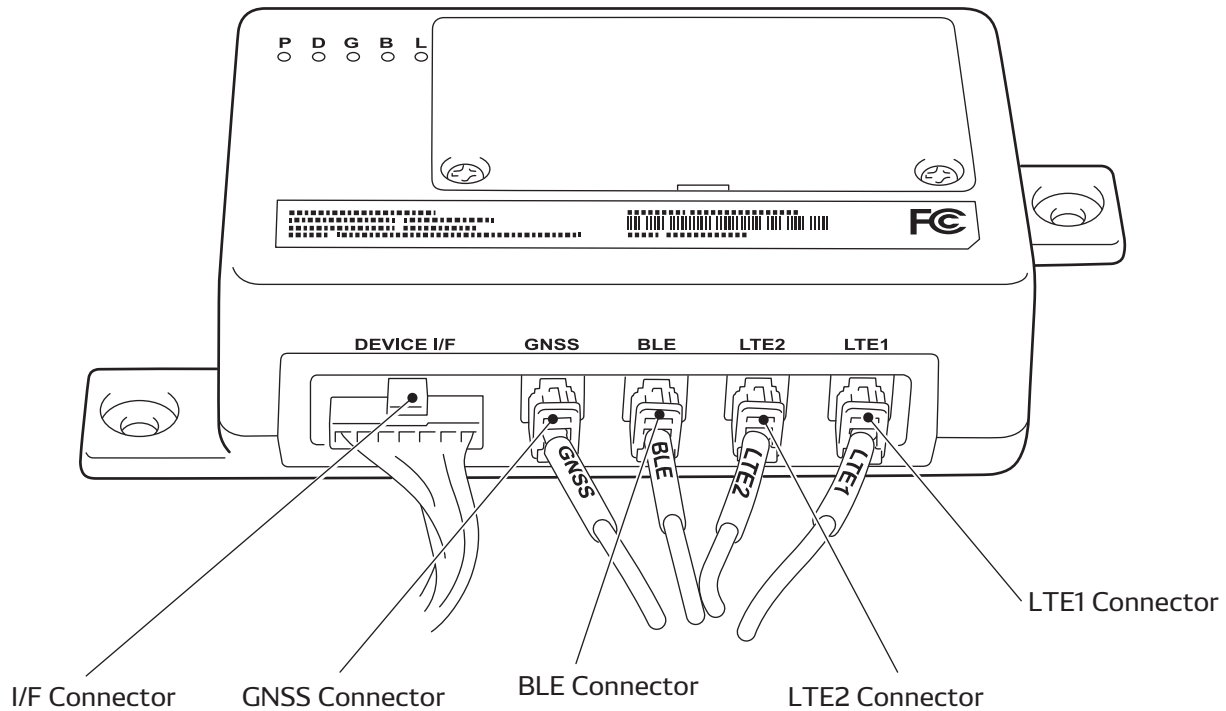

Removal of Communication Module

2. Battery Removal and Installation

Battery Specification	Model	SC-04002-02
	Nominal Voltage	3.7V
	Nominal Capacity	2500 mAh

Note:

- Before disconnecting the battery, place the battery switch to "OFF" position.
(See section 4, Set Communication Module to Operate by Internal Battery)

- a) Remove two screws from battery cover.
- b) Disconnect battery connector by pressing connector tab and pulling battery connector from the connector socket inside the module.

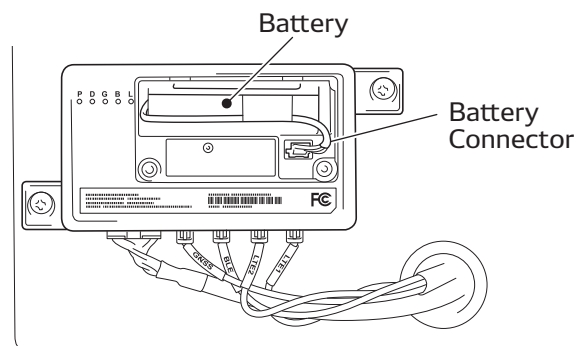

- c) To install battery, insert battery connector into the connector socket until it clicks to ensure proper connection.

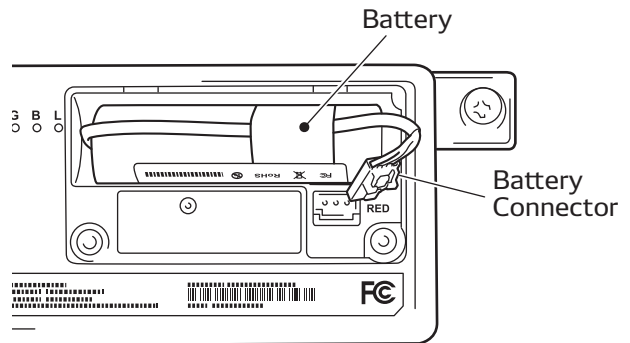

- d) Place battery in the hollow space and ensure battery wires are in place. Insert the two pins of battery cover into housing then close the cover and secure with the two screws.

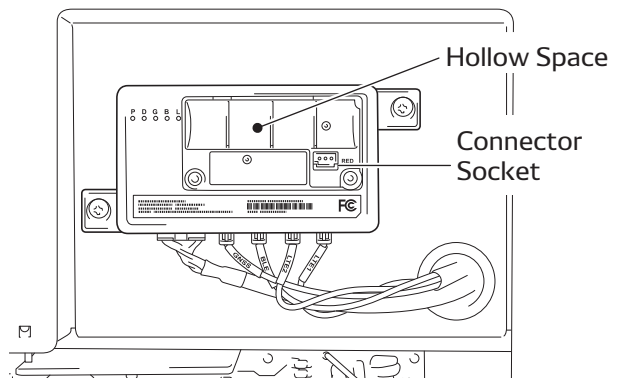

Removal of Communication Module

3. I/F Cable (see "Removal of Electrical Parts")
 - a) Follow step in control panel removal then disconnect CN2 from the control board.
 - b) Disconnect I/F connector from communication module.

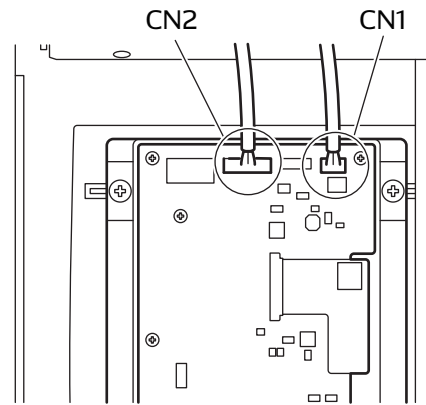

4. Set Communication Module to Operate by Internal Battery

- a) Remove service cover

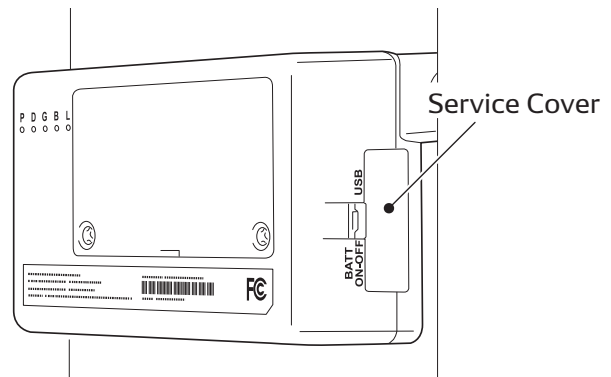

- b) Set the battery switch to "ON" position.

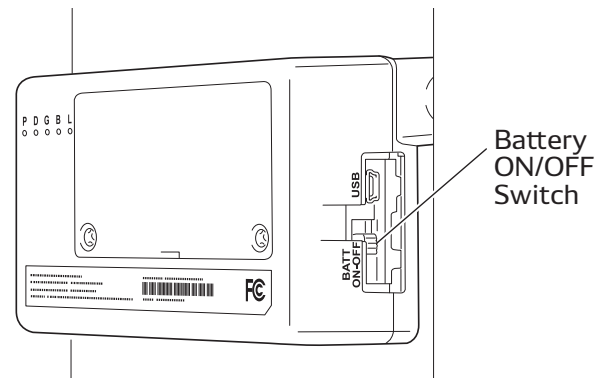

- c) Wait for network to connect, after connection L LED (orange) lights up. LEDs lights up for 3 minutes then go to sleep mode (all LEDs turn off to save battery life)

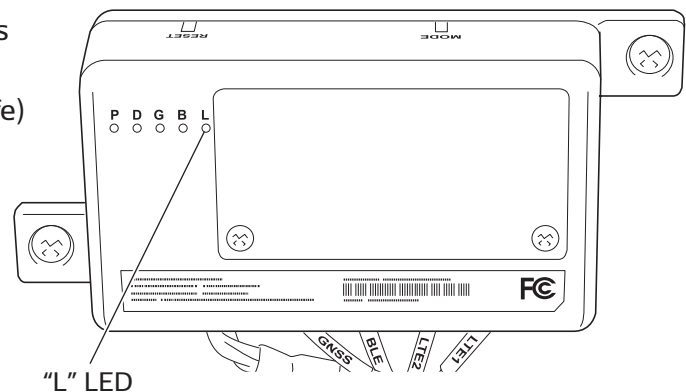

Removal of Communication Module

5. Reset Communication Module

- a) Remove service panel
- b) Use a nylon or wooden tool to press RESET button of the communication module



- Do not use sharp objects to press the reset button as it may damage the control panel.
- c) "P" LED blinks once to acknowledge that the RESET have been completed.

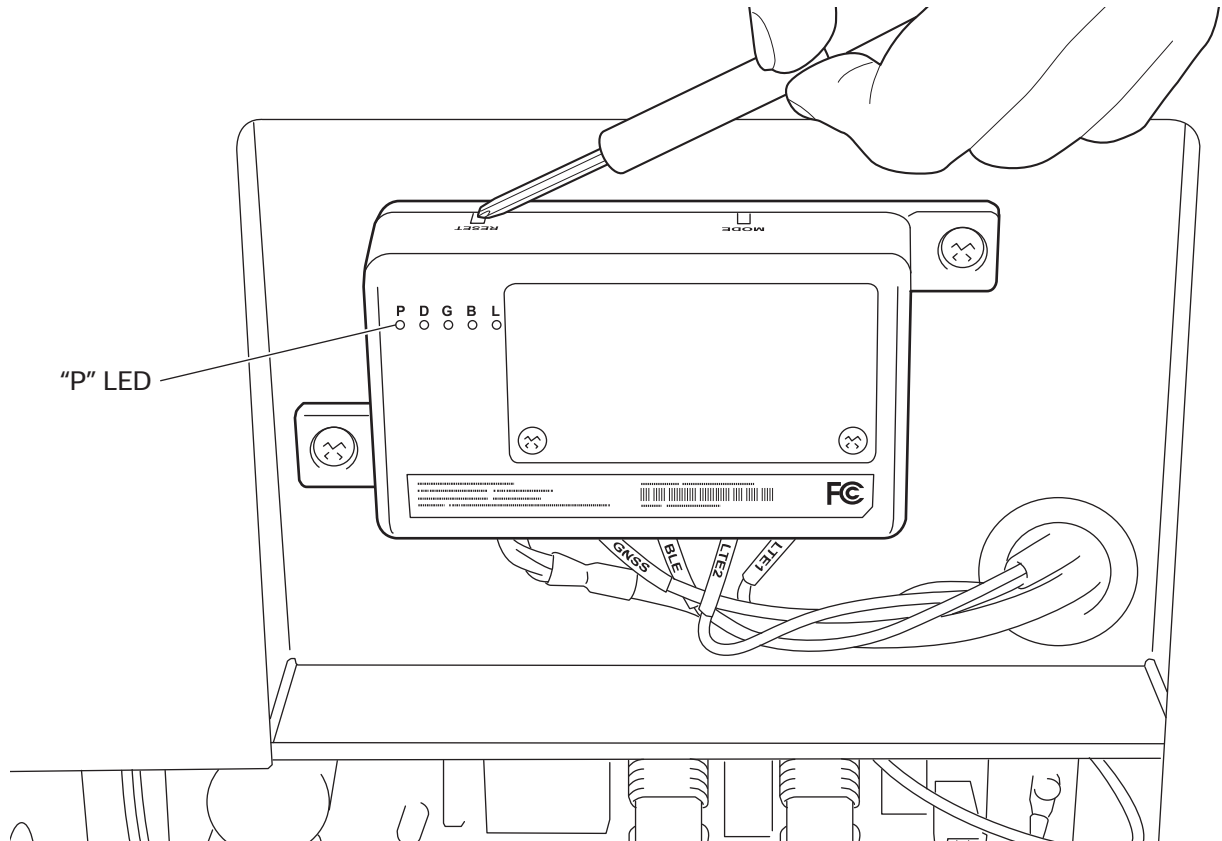

Removal of Blower Assembly

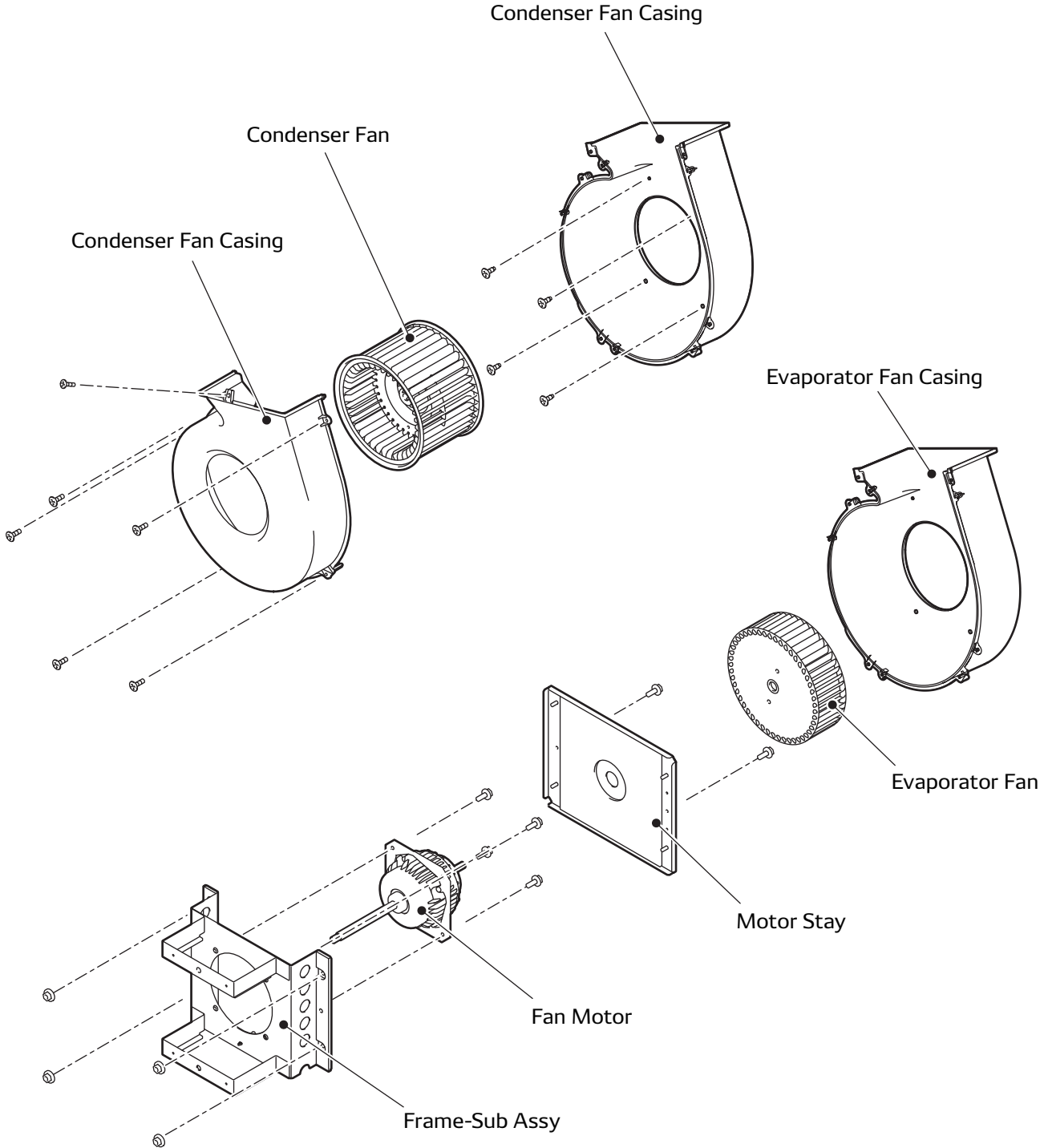

Removal of Blower Assembly

1. Remove the five (5) M4 x L12 screws and remove the half condenser fan casing.

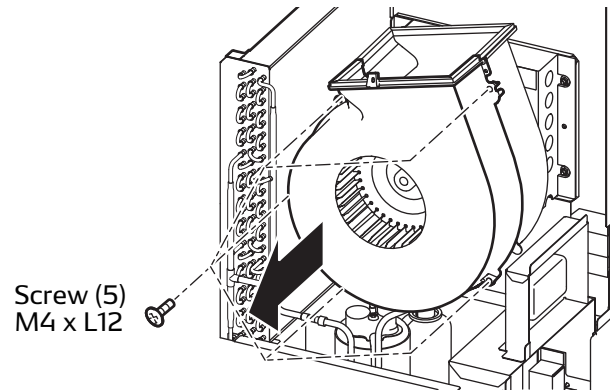

2. Loosen the set screw and remove the condenser fan.

Note:

- When reinstalling the condenser fan, fasten the set screw at the torque of 12.6 ± 1.3 ft·lbf (171 ± 1.7 N·m).

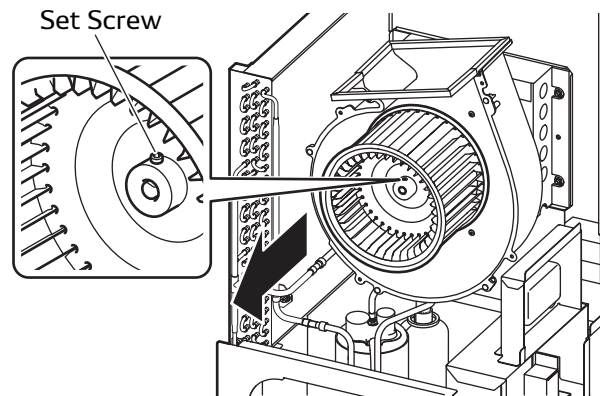

3. Remove the four (4) M4 x L10 screws and remove the other half of the condenser fan casing.

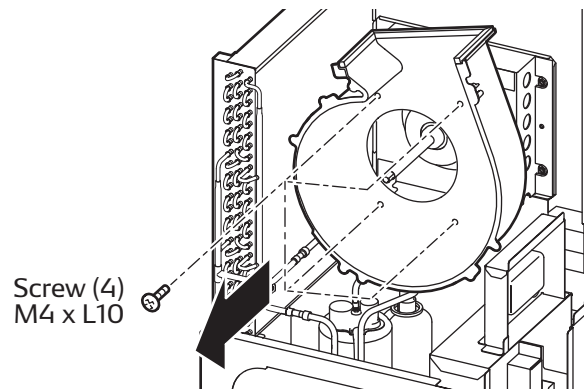

4. Remove the connector (CN21) for fan motor from the relay board.

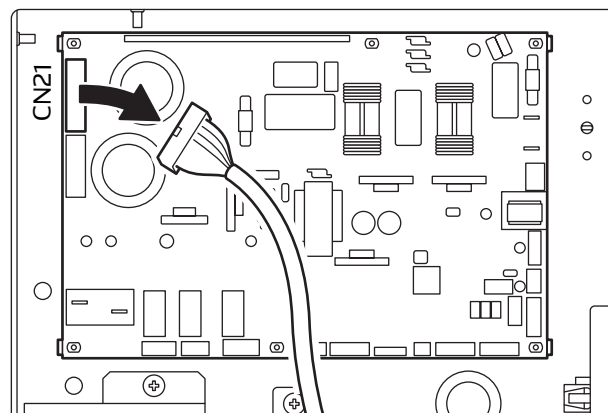

Removal of Blower Assembly

- Remove the four (4) nuts and remove the fan motor assembly.

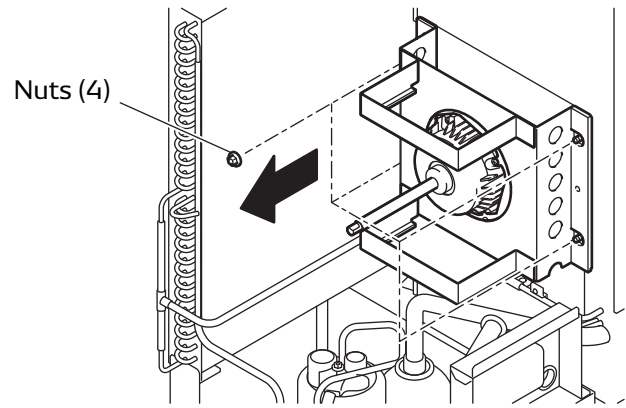

- Loosen the set screw and remove the evaporator fan.

Note:

- When reinstalling the evaporator fan, fasten the set screw at the torque of 5.5 ± 0.5 ft·lbf (7.4 ± 0.7 N·m).

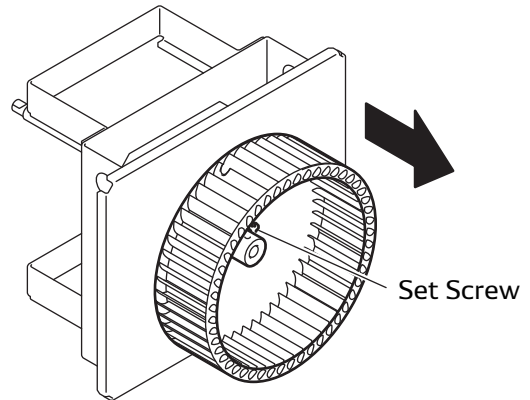

- Remove the two (2) M4 x L10 screws and remove the motor stay.

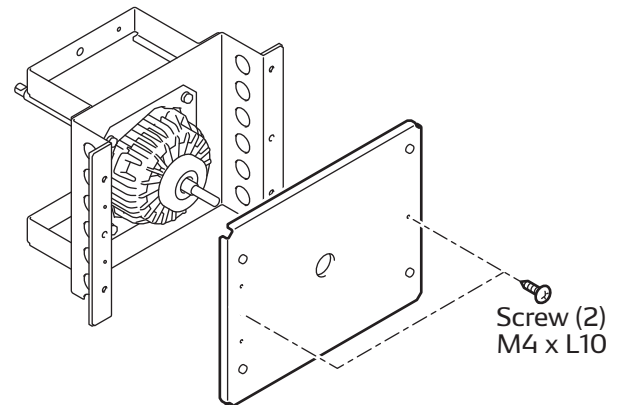

- Remove the four (4) M6 x L16 bolts and remove the fan motor.

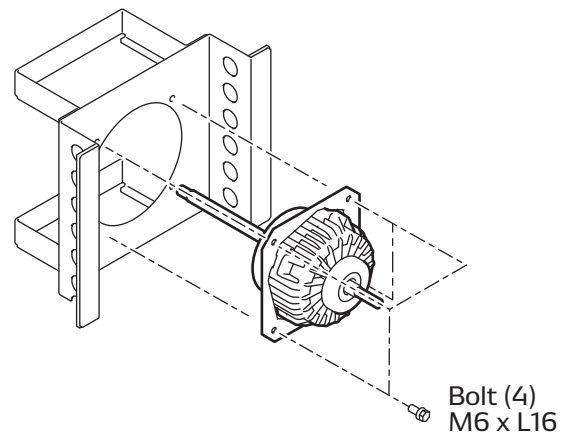

INSPECTION OF PARTS

Capacitor

1. Ohmmeter method

Set the ohmmeter to the 10M range. Place the two probes against the two terminals of the capacitor. At first, the ohmmeter should indicate a small value, and then the reading should gradually increase towards infinity. This indicates that the capacitor is charging. If the reading indicates infinity immediately (open) or the ohmmeter fails to move from 0 (short), replace the capacitor.

2. Capacitance tester

If the tester indicates the capacitance is less than 90% of the value below, replace the capacitor.

- Voltage: 260VAC
- Rating Capacitance: 45 μ F

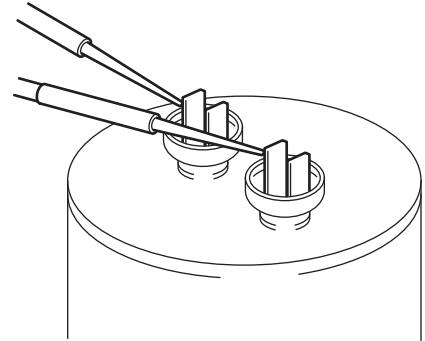

WARNING

- Always discharge the capacitor before and after testing. If not, it may cause electric shock, damage to test equipment or malfunction.

Drain Switch

Check for continuity between terminal 1 and terminal 2 when drain switch is pressed. If continuity does not exist, replace drain switch.

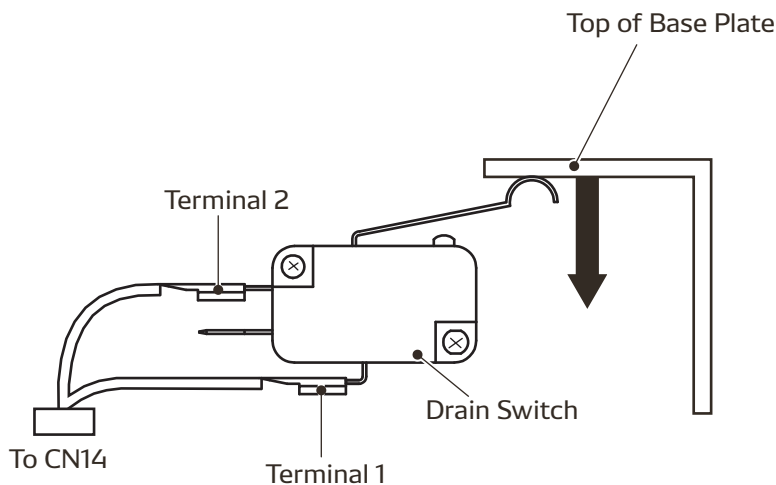

Fan Motor

Check the resistance values across the two pins listed in the table below on the 8-pin fan motor connector with an ohm-meter.

If the measured values are outside of the acceptable values, then replace the fan motor.

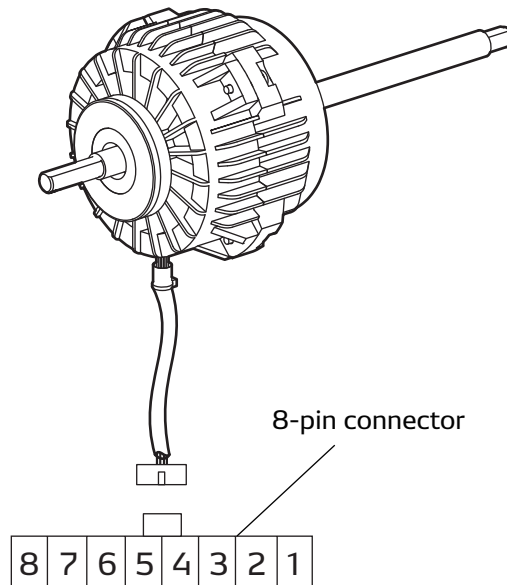

Connector Pin No.	8	7	6	5	4	3	2	1
Wire Color	White	Orange	Brown	Blue	X	X	X	Red

	Polarity of Tester		Acceptable Value
	⊕	⊖	
Connector Pin No.	1	5	1M ohm or more
		6	1M ohm or more
		7	1M ohm or more
	5	6	1M ohm or less
		7	1M ohm or less
	6	7	1M ohm or less

Compressor

1. Remove the nut and remove the cover from the compressor.

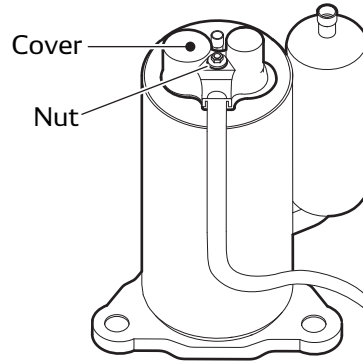

2. Compressor Motor

Disconnect the terminals: C, R and S from the compressor motor and check resistance across the terminals: Between terminals at 68 °F (20 °C)

- R-C Approx. 0.6 ohm
- C-S Approx. 2.2 ohm
- S-R Approx. 2.8 ohm

If the measured resistance is not equal to these standard values, replace the compressor.

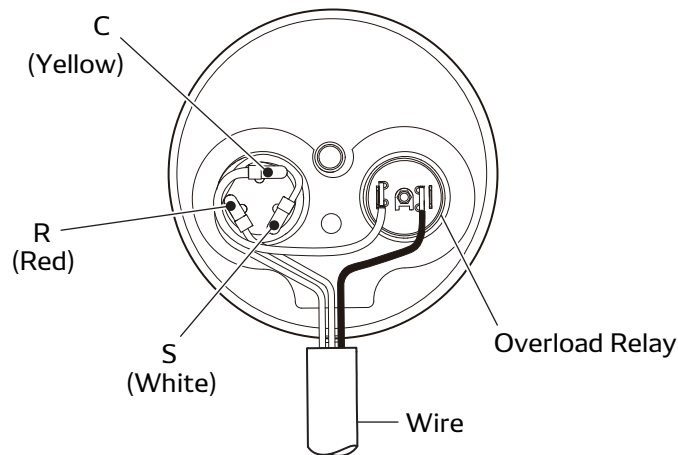

3. Overload Relay

Check for continuity across the two terminals of the overload relay. At normal temperature, there should be continuity across the terminals.

Operating temperature:

- OFF (Open): 320 °F (160 °C)
- ON (Closed): 158 °F (70 °C)

If there is no continuity across the terminals, replace the overload relay.

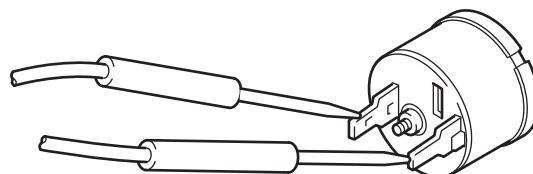

Thermistor

Check the resistance value across the 2 pins of 7- pin thermistor connector with an ohm-meter.

- RTS (Evaporator air inlet thermistor): Pin-2 and pin-7

- CTS1 (Evaporator pipe thermistor): Pin-1 and pin-4

If the measured value is outside of the thermistor specification, replace the thermistor.

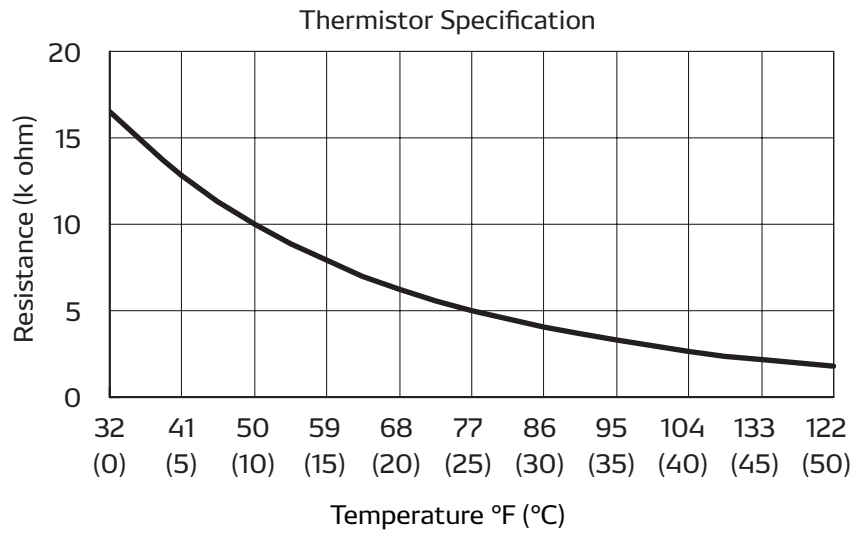
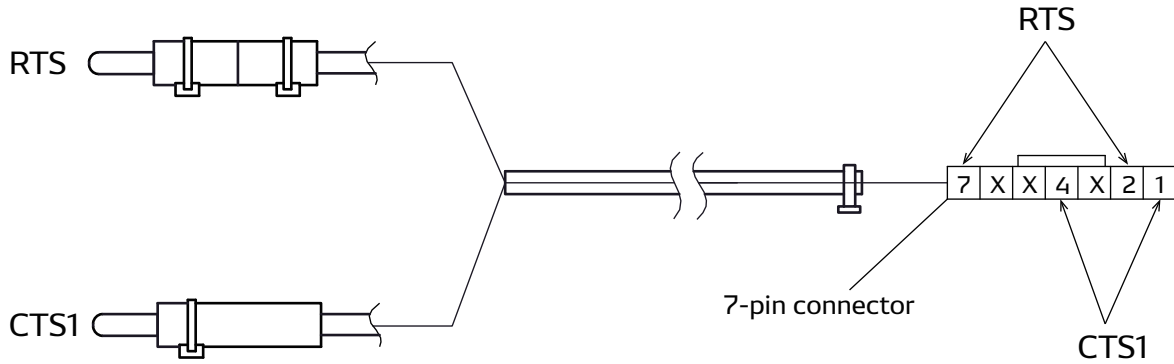

REFRIGERATION SYSTEM REPAIR

Brazing

If a problem with refrigerant system is found, replace or repair the relevant part. After replacing any part, all connections must be brazed.

WARNING

To avoid burns, lack of oxygen or unit malfunction:

- **Brazing must be performed by a qualified technician only.**
- **When brazing, always wear eye protection and gloves.**
- **Work in a well-ventilated area only.**

1. Proper brazing techniques

It is desirable to use a slightly reduced flame. Oxyacetylene is commonly used since it is easy to judge and adjust the condition of the flame. Unlike gas welding, a secondary flame is used for brazing. It is necessary to preheat the base metal properly depending on the shape, size or thermal conductivity of the brazed fitting. The most important point in flame brazing is to bring the whole brazed fitting to a proper brazing temperature. Care should be taken not to cause overflow of brazing filler metal, oxidization of brazing filler metal, or deterioration due to the overheating of flux.

2. Shape and clearance of brazed fitting

For the shape of the brazed fitting, it is necessary to maximize its adhesive area. The clearance of the brazed fitting must be minimized to facilitate the flow of the brazing metal filler by capillary action.

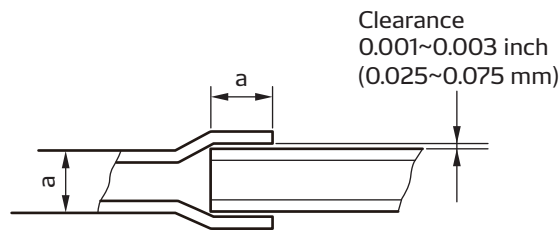

Clearance From Pipe Fitting and Tubing

3. Cleaning brazing filler metal and pipe

The surface of the metal combines with oxygen in the air and becomes covered with a very thin oxide film. Fats and oils often adhere to pipes due to handling. The metal and pipes must be cleaned before brazing. Fats and oils should be removed with a solvent such as trichlene. Rust and oxide should be removed with sand paper.

CAUTION

- **Do not use cleaners that contain chlorine. Chlorine cleaners may damage pipes.**

Brazing

4. Use of dry nitrogen gas

The brazing flame oxidizes the inner surface of the pipe. To prevent this, introduce dry nitrogen gas from the pinch-off tube of the refrigeration cycle at a rate of 0.27 gal/min (1 L/min); adjust with the flow regulator.

Note:

- Take care not to allow dirt, water, oil to enter the pipe.

5. Vertical Joint

Heat the pipes so that heat is evenly transmitted throughout the fittings.

a) Vertical Down Joint

When the fitting surface reaches the brazing temperature, add brazing metal and continue to heat, moving the burner downward as shown. The melted brazing metal flows toward higher temperature.

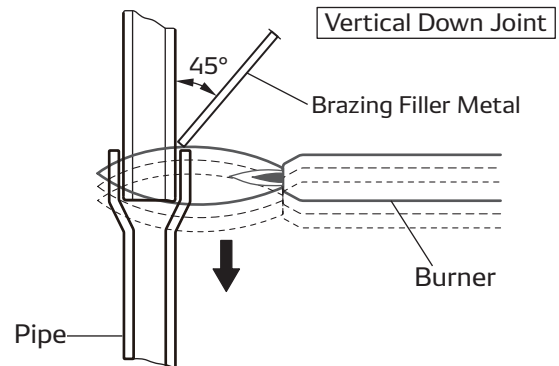

b) Vertical Up Joint

Move the burner upward as shown. The brazing metal will flow upward through capillary action and through its nature of flowing toward higher temperature.

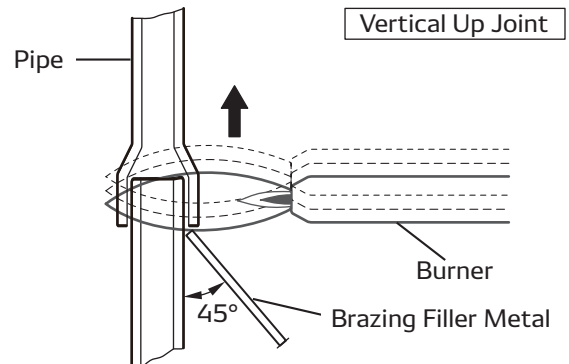

Replacement of Refrigeration Cycle Parts

The parts of refrigeration system are connected with copper tubes by brazing each connection.

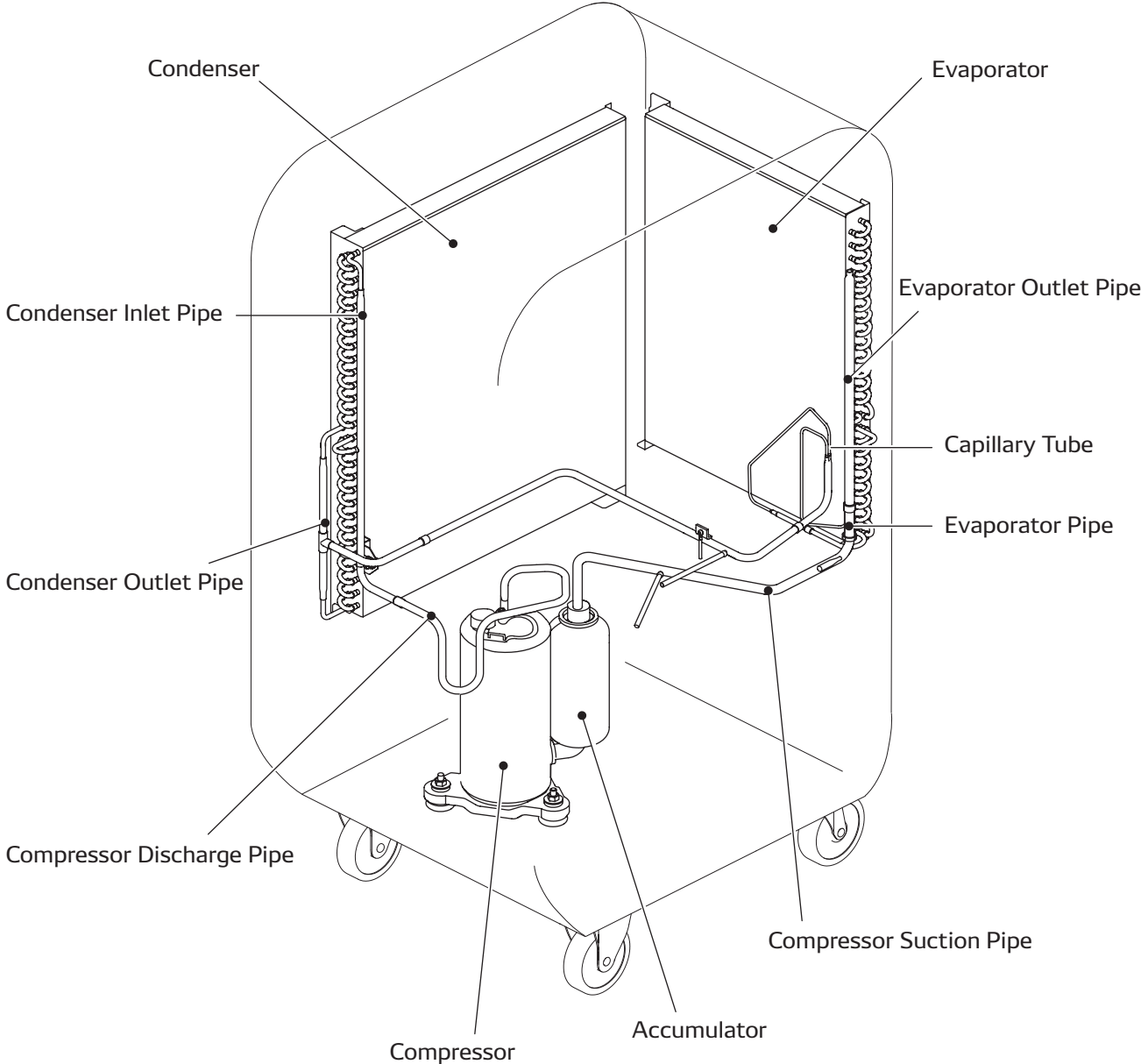

Replacement of Refrigeration Cycle Parts

Before replacing the parts, recover the refrigerant using standard recovery procedures and equipment. When recovering the refrigerant, use the pinch-off tubes on the low pressure side (tube 1) and high pressure side (tube 2) as shown.

To prevent oxidation, introduce dry nitrogen gas from the pinch-off tube at a rate of 0.27 gal/min (1 L/min); adjust with the flow regulator. During any parts replacement involving brazing, shield nearby parts with a steel plate to protect them from the flame.

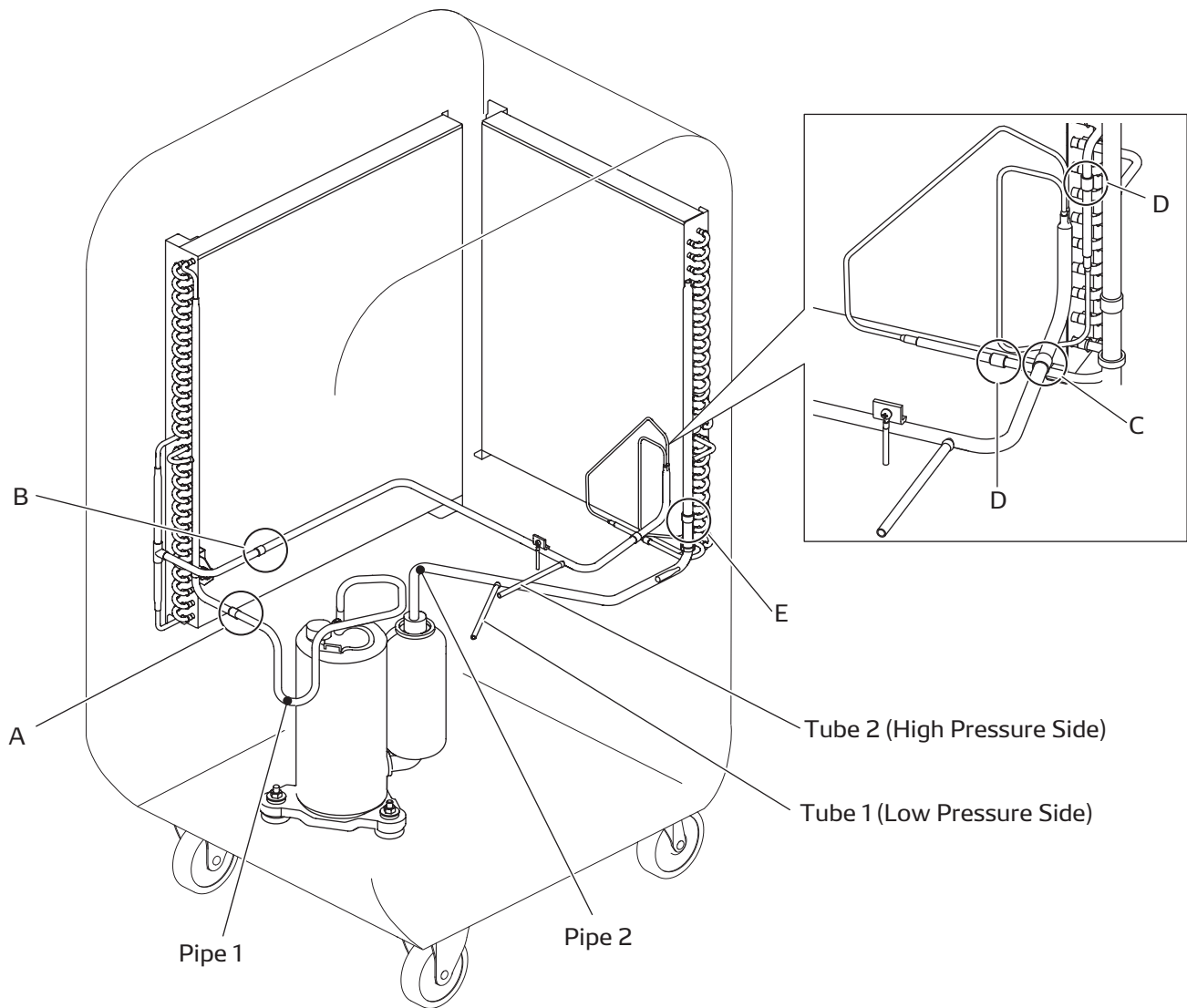

Part for Replacement	Disconnect At
Compressor	A, E
Condenser	A, B
Evaporator	D, E
Capillary Tube	C, D

Note:

- When replacing the compressor, replace pipe 1 and pipe 2 supplied with the compressor together.

Charging the System with R-410A Refrigerant

Prepare the following items:

- Gauge manifold
- Vacuum pump
- R-410A refrigerant cylinder (Use a max of 90% of the initial weight)
- Scale
- Safety goggles
- Heavy-duty work gloves

WARNING

When handling refrigerant, the following precautions should always be observed. Failure to do so may cause explosion, fire, loss of vision, lack of oxygen, burns, injury or unit malfunction.

- Refrigerant services must be performed by a licensed professional only
- Always wear proper eye protection and gloves while handling refrigerant
- Avoid working near flammable materials
- Work in well-ventilated area only
- Maintain the temperature of the refrigerant container below 104 °F (40 °C)
- Be careful not to allow refrigerant to contact eyes or skin

If liquid refrigerant strikes eye or skin:

- Do not rub the eye or skin
- Splash large quantities of cool water on the eye or skin
- Apply clean petroleum jelly to the skin
- Go immediately to a physician or hospital

Step 1	Connect gauge manifold
Step 2	1) Evacuate the system <ul style="list-style-type: none">• 15 minutes or more• 30 inHg (100 kPa) or more of vacuum 2) Stop evacuating the system <ul style="list-style-type: none">• Leave for 5 minutes 3) Check the vacuum
Step 3	Connect to refrigerant source
Step 4	Test the system for leaks
Step 5	Charge the system with R-410A See "Technical Specifications" for the specified amount
Step 6	Remove gauge manifold

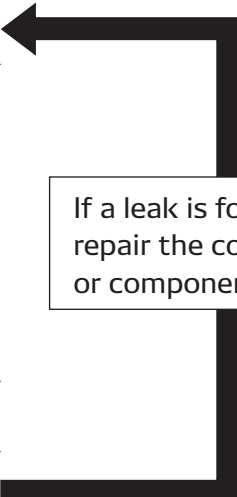

If a leak is found,
repair the connection
or components.

Charging the System with R-410A Refrigerant

1. Connection of gauge manifold
 - a) Remove the crushed end of the pinch-off tube on the high pressure side of the refrigerant cycle with a pipe cutter.
 - b) Connect the process tube fitting to the pinch-off tube on both sides.

Process Tube Fitting

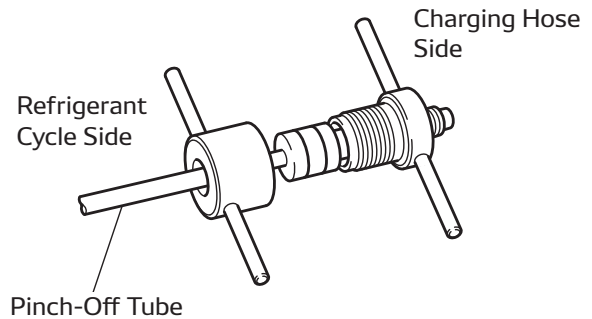

- c) Connect the red charging hose of the gauge manifold to the process tube fitting on the high pressure side.

Note:

- Red hose is for high pressure side and blue hose (not shown) is for low pressure side.
- d) Connect the charging hose (yellow) to the center of the gauge manifold to the vacuum pump.

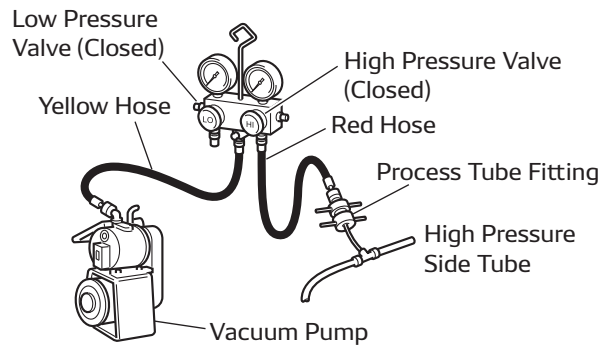

2. Evacuation

- a) Open the high pressure valve (HI) of the gauge manifold.
 - b) Turn on the vacuum pump to start evacuation. It takes 15 minutes.
 - c) When the low pressure gauge indicates 30 inHg (100 kPa) or larger, turn off the vacuum pump and close the high pressure valves of the gauge manifold.

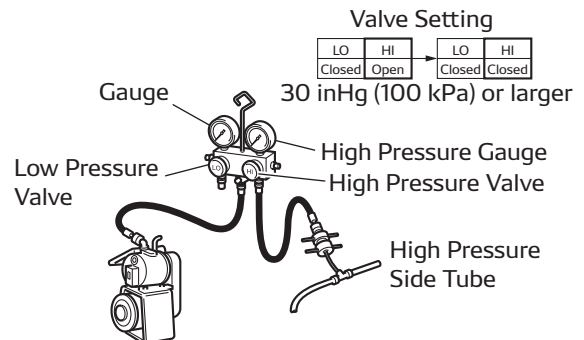

3. Checking vacuum

- a) Leave the high and low pressure valves of the gauge manifold closed for 5 minutes or more, and confirm that the gauge pointer does not return to zero.
 - b) If the gauge pointer returns gradually to zero, perform leak check according to the procedure in the next step. After repairing the leaks, evacuate the system once more and check vacuum.

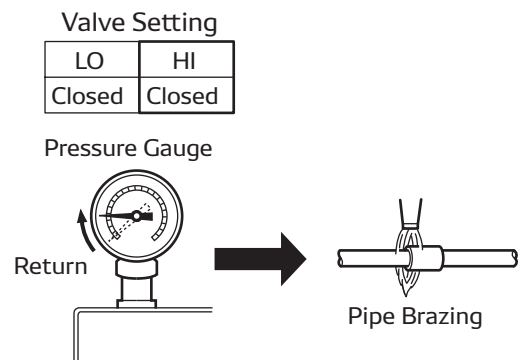

Charging the System with R-410A Refrigerant



WARNING

Avoid working near flammable materials. Working near flammable materials may cause explosion or fire. Refrigerant may generate toxic gas if it comes into contact with an open flame or heated metal.

4. Checking gas leak

- Remove the charging hose from the vacuum pump and connect the hose to the refrigerant cylinder.
- Loosen the nut on the gauge manifold side of the charging hose.
- Open the valve of refrigerant cylinder and perform air purging in the charging hose. Then tighten the nut

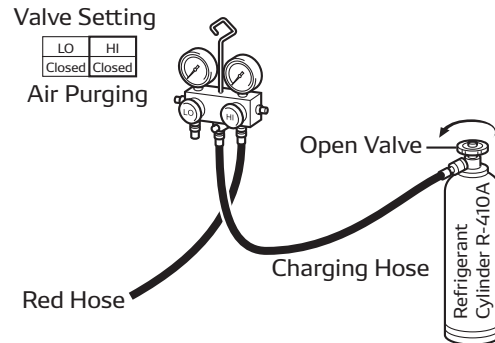

- Open the high pressure valve of the gauge manifold. Charge the system with refrigerant until the low pressure gauge indicates 57 psi (390 kPa). After charging is complete, close the high pressure valve.
- Open the valve of refrigerant cylinder and perform air purging in the charging hose. Then tighten the nut.
- Check for gas leaks with a gas leak detector.
- Repair any leak.

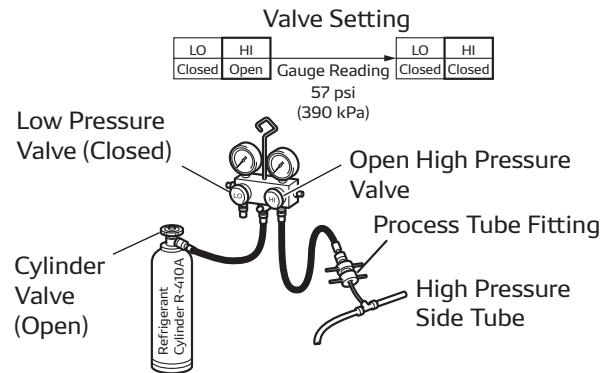

5. Evacuation (repeat)

- Close the valve of the refrigerant cylinder, remove the charging hose and connect the hose to the vacuum pump. Keep the high and low pressure valves of the gauge manifold closed.
- Follow the procedure "Evacuation" on page 49. Perform evacuation twice or more to completely remove air or moisture in the system before charging refrigerant.

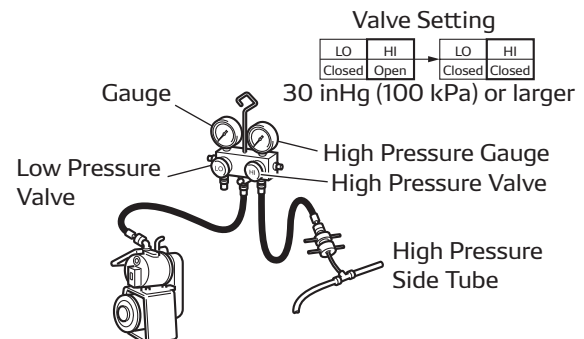

Charging the System with R-410A Refrigerant

6. Checking gas leak

- a) Remove the charging hose from the vacuum pump and connect it to the refrigerant cylinder.
- b) Loosen the nut on the gauge manifold side of the charging hose and open the valve of the refrigerant cylinder. After air purging, tighten the nut and close the valve of the refrigerant cylinder.
- c) Securely place the refrigerant cylinder on a scale with a weighing capacity of 70 lb (30 kg) that is graduated to 0.2 oz (5 g).
- d) Open the high pressure valve of the gauge manifold and the valve of the refrigerant cylinder. Charge the system with refrigerant to the specified amount.

Amount of Refrigerant: 1.65 lb (0.75 kg)

Note:

- If the ambient temperature is low or the amount of refrigerant in the cylinder is low you may need to place a warm blanket around the cylinder or place it in the sun to increase the cylinder pressure.
- e) Close the high pressure valve of the gauge manifold and the valve of the refrigerant cylinder.

Note:

- Refrigerant disposal must be conducted according to all official laws and regulations in your state/city.

7. Removal of gauge manifold

- a) Crimp the pinch-off tube with a pinch-off tool.
- b) Remove the gauge manifold and the process tube fitting. Crush the end of the pinch-off tube.
- c) Braze the end of the pinch-off tube.
- d) Ensure that a gas leak is not present at the pinched off portion and the brazed end.

Note:

- Follow the standard gauge manifold procedure. After repairing the leaks, evacuate the system once more and check vacuum.

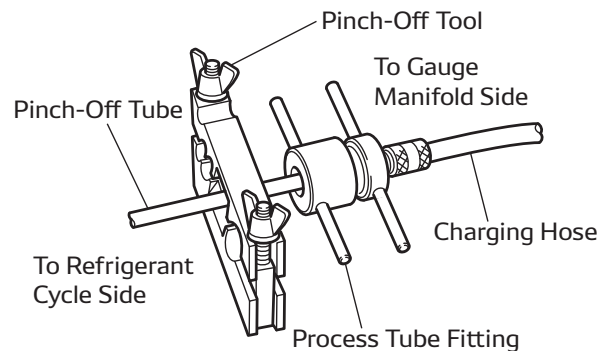
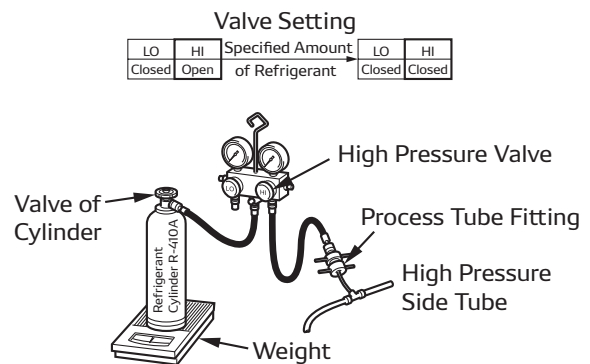
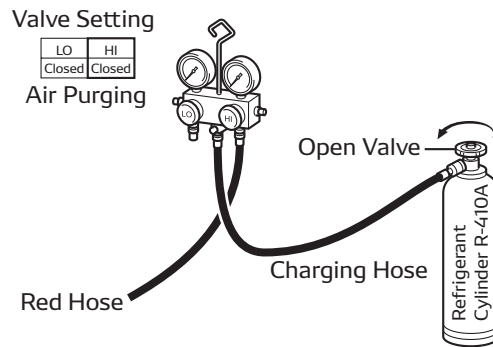

REASSEMBLY

Reassemble the unit in the reverse order of removal. The following parts require special care in reassembling the unit.

Wiring Diagram

Perform all wiring or rewiring as referenced in the wiring diagram.

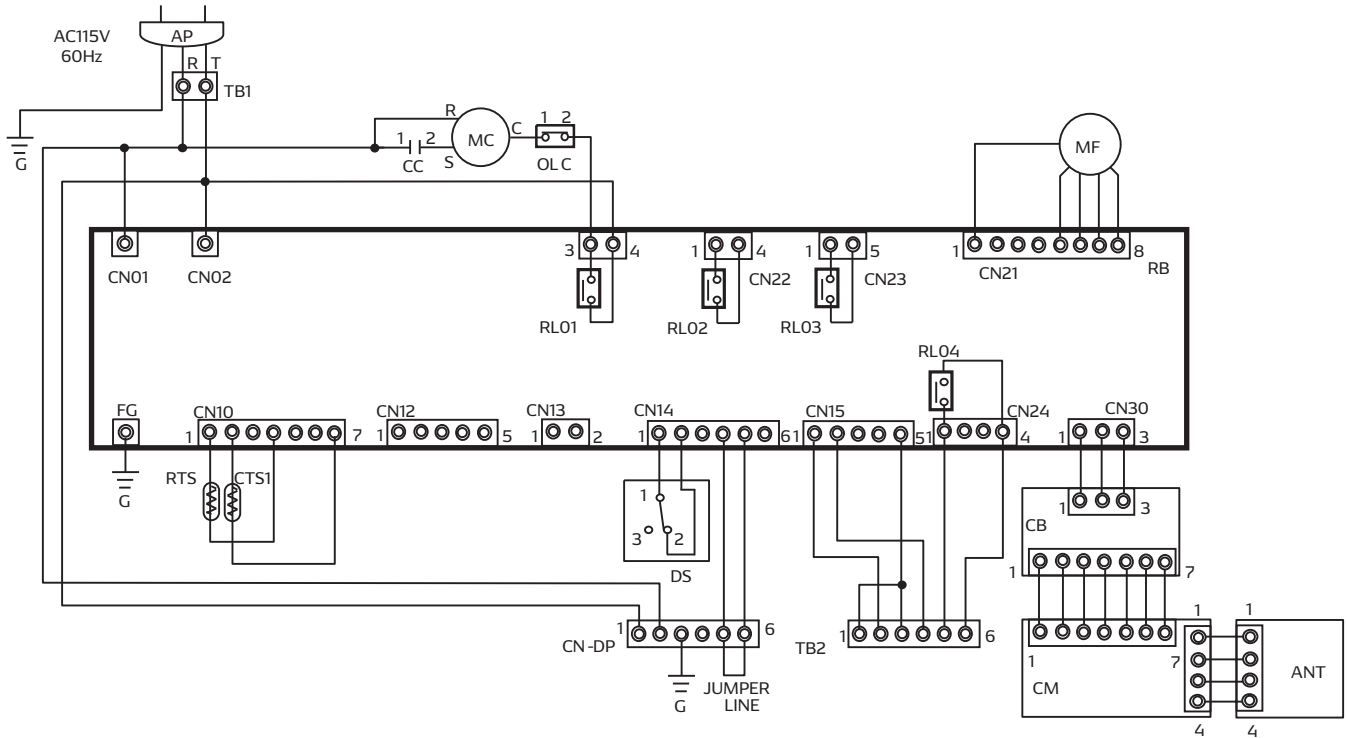

AP	Attachment Plug	OLC	Overload Relay for Compressor
TB1	Terminal Block	DS	Full Drain Warning Switch
TB2	Terminal Block	CTS1	Freeze Protection Thermistor
CB	Control Board	RTS	Room Thermistor
RB	Relay Board	G	Grounding
MF	Fan Motor	CN-DP	Connector for Drain Pump
MC	Compressor Motor	CM	Communication Module
CC	Capacitor for Compressor	ANT	Antenna

Note:

- Secure the wires with clamps to prevent contact with the edges of the parts of the unit. Re-secure the wires in the same position as prior to removal.

Compressor Mounting

1. Install the three (3) cushions on the bolts.
2. Mount the compressor in the unit.
3. Insert the three (3) nuts and fasten at the torque of 8.3 ± 2.1 ft·lbf (11.3 ± 2.9 N·m)

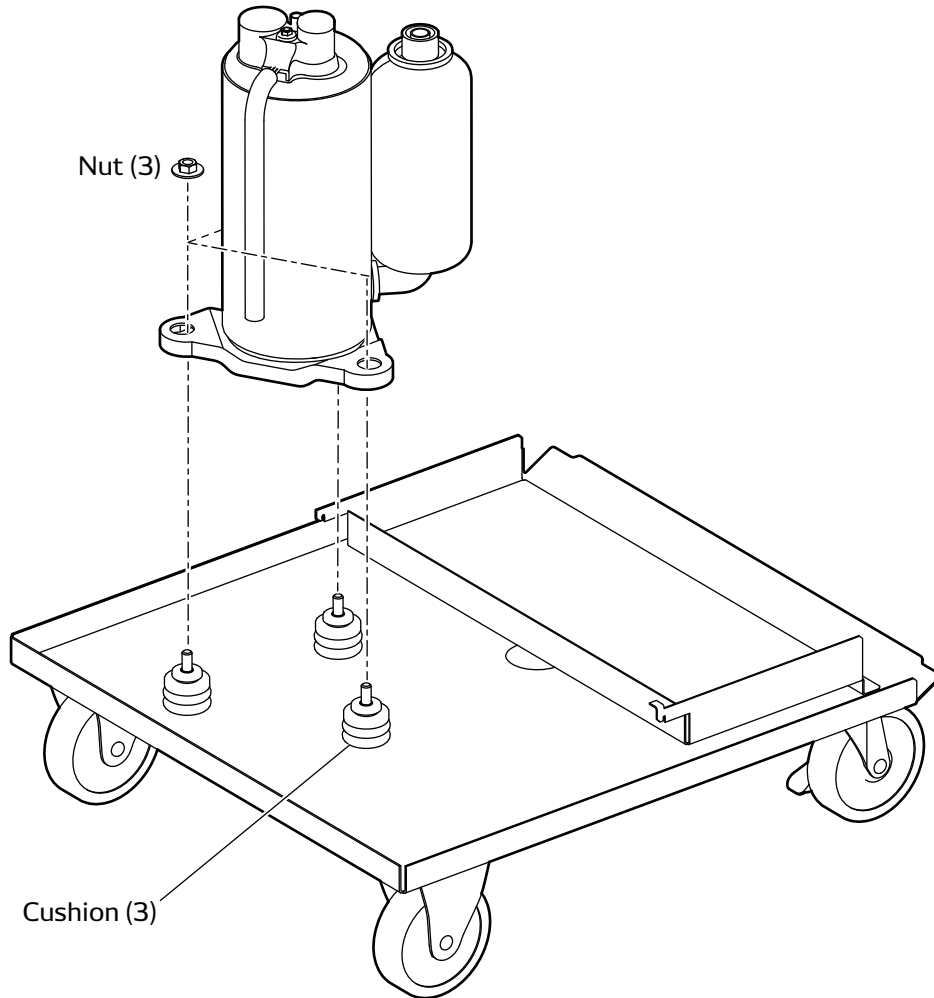

Caster Maintenance

Lubricate bearings in caster as needed with standard bearing grease using the zerk fitting. Check if casters roll and swivel freely. Remove any build-up dirt or dust.

DATA PRIVACY DISCLOSURE

Tracking of Machine Operation Data

This Unit is equipped with an embedded module that collects and transmits to us data on the Unit's operational performance ("Machine Operation Data"), including:

1. Hours of operation
2. Control Panel settings
3. Ambient Temperature
4. Error Codes
5. Geolocation

How We Use the Data We Collect

The embedded module collects the Machine Operation Data in a format that is used for business analysis purposes, and does not identify the user. However, Machine Operation Data may become personal information about an identifiable individual when it is read together or combined with other personal information.

We use the Machine Data to:

- (i) Monitor the performance of the Unit.
- (ii) Analyze the performance of the Unit under actual environmental conditions.
- (iii) Analyze the performance of the Unit under actual user demand conditions.
- (iv) **Locate the Unit.**
- (v) Use aggregate data to enhance the performance, efficiency and usefulness of our products.
- (vi) Use aggregate data to modify, improve or develop new products, services and technologies.
- (vii) Comply with legal, regulatory or contractual requirements.

When you purchase or lease a Unit from us or one of our authorized distributors or resellers, we may obtain personally identifying information about you such as your name, address, phone number and e-mail address ("Personally Identifying Information"). We and our authorized distributors or resellers may use Machine

Operation Data together with Personally Identifying Information to:

- (i) Assist in trouble shooting and repair.
- (ii) Provide any safety updates or recall notices.
- (iii) Provide warranty service.
- (iv) Provide and improve customer support.
- (v) **Locate the Unit.**

The Machine Operation Data will be transmitted to us in the United States. While Machine Operation Data is in the United States it may be accessed by the courts, law enforcement and national security authorities pursuant to local U.S. laws.

Sharing of Data

We shall use Machine Operation Data primarily for our own business purposes. We may also share your Unit's Machine Operation Data with the distributor, reseller or owner that sells or leases the Unit to you. This means that they will be able to determine the geolocation of the Unit.

We may disclose Machine Operation Data to a third party service provider in the United States for processing in order to analyze the performance of the Units and make improvements. The third party service provider is contractually bound to use Machine Operation Data solely for the purpose of providing services to us and not for their own purposes.

Sharing of Data

We shall use Machine Operation Data primarily for our own business purposes. We may also share your Unit's Machine Operation Data with the distributor, reseller or owner that sells or leases the Unit to you. This means that they will be able to determine the geolocation of the Unit.

We may disclose Machine Operation Data to a third party service provider in the United States for processing in order to analyze the performance of the Units and make improvements. The third party service provider is contractually bound to use Machine Operation Data solely for the purpose of providing services to us and not for their own purposes.

How Long We Keep Your Information

We may keep the information we collect for as long as necessary to provide products or services to you, to operate our business, to enable us to communicate with you, for our safety, research, evaluation of use, or troubleshooting purposes, or to satisfy our legal or contractual obligations. Where required, we will de-identify or dispose of the information we collect when we no longer need it for the uses described above.

CONSUMER RIGHT TO "OPT OUT" OF DATA SHARING

If you are a consumer and you do not want us to provide your Unit's Machine Operation Data, including the Unit's geolocation, or your Personally Identifying Information to your supplying distributor, reseller or owner, you may "Opt Out" by contacting us at 1-800-264-9573 or www.movincool.com

If you are a consumer and you do not want us to use a third party service provider to process your Unit's Machine Operation Data, you may "Opt Out" by contacting us at 1-800-264-9573 or www.movincool.com

CONSENT TO OUR COLLECTION, USE AND DISCLOSURE OF MACHINE OPERATION DATA

By reading this notice and using this Unit, you consent to our collection, use and disclosure of Machine Operation Data. If you do not wish to give your consent, we will disable the Machine Operation Data tracking module upon request at 1-800-264-9573 or www.movincool.com

CONSENT TO OUR COLLECTION, USE AND DISCLOSURE OF GEOLOCATION DATA

By reading this notice and using this Unit, you consent to our collection, use and disclosure of geolocation data. If you do not wish to give your consent, we will disable the Machine Operation Data tracking module upon request at 1-800-264-9573 or www.movincool.com The tracking of geolocation data is an integral function of the Machine Operation Data tracking module. Therefore, disabling the geolocation functionality will disable all other functionality of the Machine Operation Data tracking module. If the Machine Operation Data tracking module is disabled, we will not be able to provide you with any accompanying customer service enhancements.

CONSUMER RIGHT TO WITHDRAW CONSENT

If you no longer wish to consent to our use, collection and disclosure of Machine Operation Data, you may contact us at 1-800-264-9573 or www.movincool.com and we will disable the Machine Operation Data tracking module.

For further information about our privacy policy or our privacy management practices, please refer to www.movincool.com

DENSO

DENSO PRODUCTS AND SERVICES AMERICAS, INC.

Long Beach, CA 90810

www.movincool.com