

**FFMA**  
**Base Series Fan Coil**  
**Sizes 018 thru 037**



## Product Data

### FEATURES

The FFMA Series Fan Coil unit is primarily designed for apartment applications as an upflow only indoor fan coil for split-system heat pumps for use with Puron® refrigerant. Accessory field-installed electric heat kits are available in 5, 7.5 or 10 kW sizes. The 018, 024, 030, and 036 size units use a piston refrigerant metering device. The 019, 025, 031 and 037 size units come equipped with a TXV. All unit sizes are factory-configured for Puron refrigerant. However, they can be used for R-22 applications with the addition of an accessory R-22 TXV kit.

This fan coil may be installed in a frame mount or wall hung applications. The cabinet sizes allow units to fit between standard stud spacings. No return-air ductwork is required if the application provides for return air in the front of the cabinet through a louvered closet door or optional louvered wall panel. This unit is field convertible to bottom return without the need for an additional accessory kit.

The cabinet exterior is made of galvanized sheet metal and is sealed to limit cabinet air leakage to 2% when tested at 1.0 inches of static pressure and 1.4% when tested at 0.5 inches of static pressure. The cabinet is fully insulated to meet applications in conditioned space. This unit is not approved for installation in unconditioned spaces.

The FFMA 018, 024, 030, and 036 sizes use a 3-speed PSC motor. The FFMA 019, 025, 031, and 037 sizes use a 5-speed multi-tap ECM motor for efficiency. Motors are suspended at three points on rubber grommets for quieter operation. Coils are tin-plated copper tube, aluminum fin.

Refrigerant lines and thermostat low voltage connections are made through the top while the high voltage connections are made from either the right, left or top side of the fan coil. Sweat-type refrigerant connections on both liquid and vapor lines make for swift, low-cost installation. All service access to the unit is conveniently located in the front.

Primary and secondary drain connections exit from the bottom or either side of the cabinet. Fresh air intake holes measuring 3.4" (35 mm) are located on each side of the unit cabinet and come capped from the factory.



A13417

# MODEL NUMBER NOMENCLATURE

1 2 3 4 5 6 7 8 9 10 11 12  
 F F M A N P 0 1 8 T 0 0

**Product**

F = Fan Coil

**Type**

F = Thru-the-Wall

**Position**

M = Upflow/Apartment

**Series**

A

**Electrical**

N = 208/230v, 1ph-60 Hz

**Refrigerant**

P = Puron® (R-410A)

**Heating Size**

00 = No Factory-Installed

Electric Heat

**Tube Type**

0 = Copper

T = Tin Plate

**Capacity**

018, 019 = 18,000

024, 025 = 24,000

030, 031 = 30,000

036, 037 = 36,000



Use of the AHRI Certified TM Mark indicates a manufacturer's participation in the program. For verification of certification for individual products, go to [www.ahridirectory.org](http://www.ahridirectory.org).



## DIMENSIONS

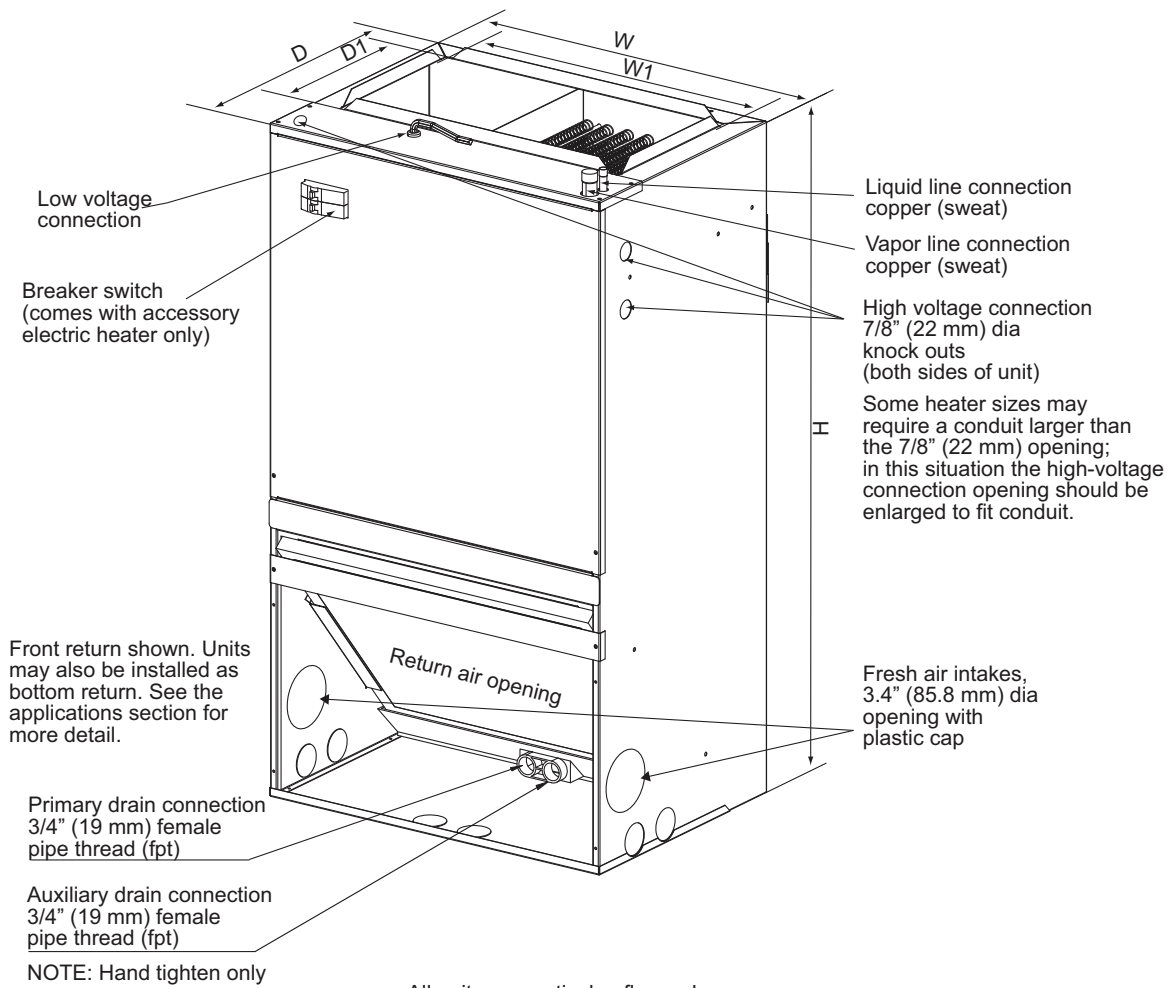

All units are vertical upflow only.  
Equipment shown with field-installed electric heat.

A150161

**Fig. 1 - Dimensional Drawing with Circuit Breaker**

### DIMENSIONAL DATA

Model Size	Dimensions- In. (mm)					Unit Weight / Shipping Weight Lbs. (kg)
	Unit Height H	Unit Width W	Unit Width W1	Unit Depth D	Unit Depth D1	
<b>18, 19</b>	36-1/2 (928)	20-1/2 (521)	17-2/5 (452)	15 (381)	9-1/2 (242)	88 / 99 (40 / 45)
<b>24, 25</b>	36-1/2 (928)	20-1/2 (521)	17-2/5 (452)	15 (381)	9-1/2 (242)	88 / 99 (40 / 45)
<b>30, 31</b>	39-1/2 (1004)	22 (559)	18-4/5 (478)	19 (483)	9-1/2 (242)	110/ 121 (50 / 55)
<b>36, 37</b>	39-1/2 (1004)	22 (559)	18-4/5 (478)	19 (483)	9-1/2 (242)	110/ 121 (50 / 55)

## SPECIFICATIONS

FFMANPO	Unit Size			
	18	24	30	36
Nominal Cooling Capacity (BTUH)	18,000	24,000	30,000	36,000
<b>COIL</b>				
Puron- Refrigerant metering Device * (Piston)	50	57	65	72
Fins Per In.	17	17	17	17
Face Area Ft <sup>2</sup>	2.1	2.1	3.0	3.0
Coil Configuration	Slope			
<b>BLOWER &amp; MOTOR</b>				
Air Discharge	Upflow			
Blower Type	Direct Drive			
CFM (Nominal)	600	800	1000	1200
Motor Type	PSC	PSC	PSC	PSC
Motor HP	1/6	1/4	1/3	1/2
Rated RPM	1075	1075	1075	1075
Motor Speeds	3	3	3	3
<b>FILTER</b>				
Field Installed	16x20x1 (406x508x25)	16x20x1 (406x508x25)	20x20x1 (508x508x25)	20x20x1 (508x508x25)
<b>CONNECTIONS (Sweat)</b>				
Suction – in. (mm)	3/4 In. (19 mm)			
Liquid – in. (mm)	3/8 In. (9.5 mm)			
Condensate (FPT) In. (mm)	3/4 In. (19 mm)			
<b>ELECTRICAL DATA</b>				
Voltage	208/230	208/230	208/230	208/230
Hertz	60	60	60	60
Circuit Amps	0.8	1.0	1.28	1.8
Minimum Circuit Ampacity	1	1.3	1.6	2.3
Maximum Circuit Protector	15 (A)	15 (A)	15 (A)	15 (A)

\* The piston included with the fan coil is unique to this product and **CANNOT** be replaced with the piston shipped with outdoor unit. Refer to the AHRI ratings to check if your combination can use the piston shipped with the unit or requires an accessory TXV.

FFMANPO	Unit Size			
	19	25	31	37
Nominal Cooling Capacity (BTUH)	18,000	24,000	30,000	36,000
<b>COIL</b>				
Puron- Refrigerant metering Device	TXV			
Fins Per In.	17	17	17	17
Face Area Ft <sup>2</sup>	2.1	2.1	3.0	3.0
Coil Configuration	Slope			
<b>BLOWER &amp; MOTOR</b>				
Air Discharge	Upflow			
Blower Type	Direct Drive			
CFM (Nominal)	600	800	1000	1200
Motor Type	ECM	ECM	ECM	ECM
Motor HP	1/3	1/3	1/2	1/2
Rated RPM	1050	1050	1050	1050
Motor Speeds	5	5	5	5
<b>FILTER</b>				
Field Installed	16x20x1 (406x508x25)	16x20x1 (406x508x25)	20x20x1 (508x508x25)	20x20x1 (508x508x25)
<b>CONNECTIONS (Sweat)</b>				
Suction – in. (mm)	3/4 In. (19 mm)			
Liquid – in. (mm)	3/8 In. (9.5 mm)			
Condensate (FPT) In. (mm)	3/4 In. (19 mm)			
<b>ELECTRICAL DATA</b>				
Voltage	208/230	208/230	208/230	208/230
Hertz	60	60	60	60
Circuit Amps	1.9	1.9	2.7	2.7
Minimum Circuit Ampacity	2.4	2.4	3.4	3.4
Maximum Circuit Protector	15 (A)	15 (A)	15 (A)	15 (A)

## PERFORMANCE DATA

### PSC- AIRFLOW PERFORMANCE (STANDARD CFM)

MODEL SIZE	BLOWER SPEEDS	EXTERNAL STATIC PRESSURE (In. W.C.)							
		0	0.1	0.2	0.3	0.4	0.5	0.6	0.7
18	High	776	733	695	653	610	564	525	464
	Med	661	624	585	546	502	454	415	354
	Low	565	529	487	448	405	353	299	244
24	High	917	881	830	790	739	687	631	564
	Med	819	785	745	703	654	604	544	480
	Low	668	631	591	551	506	464	403	343
30	High	1236	1176	1115	1064	1000	936	861	793
	Med	1113	1065	1014	962	908	842	772	701
	Low	935	894	852	807	755	694	631	561
36	High	1350	1292	1228	1167	1108	1045	981	902
	Med	1266	1198	1139	1088	1029	970	905	831
	Low	1115	1066	1015	966	918	861	801	722

— Shaded boxes represent airflow outside the required 300-450 cfm/ton.

#### NOTES:

- Airflow based upon dry coil at 230V with no electric heat and factory-approved filter.
- Airflow is equivalent for front or bottom return configurations.

### ECM AIRFLOW PERFORMANCE (STANDARD CFM)

MODEL SIZE	BLOWER SPEEDS	EXTERNAL STATIC PRESSURE (IN WC.)								
		0	0.1	0.2	0.3	0.4	0.5	0.6	0.7	0.8
19	Tap (5)	884	854	833	803	771	737	700	668	632
	Tap (4)	796	767	737	709	675	645	612	579	538
	Tap (3)	714	681	654	616	588	555	527	494	459
	Tap (2) - Factory	653	619	584	558	525	494	463	434	396
	Tap (1)	581	545	511	472	440	407	374	344	329
25	Tap (5)	884	854	833	803	771	737	700	668	632
	Tap (4) - Factory	796	767	737	709	675	645	612	579	538
	Tap (3)	714	681	654	616	588	555	527	494	459
	Tap (2)	653	619	584	558	525	494	463	434	396
	Tap (1)	581	545	511	472	440	407	374	344	329
31	Tap (5)	1309	1272	1236	1200	1164	1125	1088	1051	1010
	Tap (4)	1122	1088	1056	1022	986	950	915	877	836
	Tap (3)	1109	1073	1038	1003	973	937	901	867	828
	Tap (2) - Factory	1010	975	941	904	869	835	793	751	704
	Tap (1)	936	899	862	833	793	755	710	664	619
37	Tap (5)	1309	1272	1236	1200	1164	1125	1088	1051	1010
	Tap (4) - Factory	1122	1088	1056	1022	986	950	915	877	836
	Tap (3)	1109	1073	1038	1003	973	937	901	867	828
	Tap (2)	1010	975	941	904	869	835	793	751	704
	Tap (1)	936	899	862	833	793	755	710	664	619

— Shaded boxes represent airflow outside the required 300-450 cfm/ton.

#### NOTES:

- Airflow based upon dry coil at 230V with no electric heat and factory-approved filter. For 19, 25, 31 and 37 sizes, airflow at 208V is approximately the same as 230V because the multi-tap ECM motor is a constant torque motor. The torque doesn't drop off at the speeds in which the motor operates.
- Airflow is equivalent for front or bottom return configurations.

### AIRFLOW PERFORMANCE (CFM)

Size	CFM	
	Min	Max
18 / 19	450	675
24 / 25	600	900
30 / 31	750	1125
36 / 37	900	1350

## PERFORMANCE DATA (CONT.)

### GROSS COOLING CAPACITIES (mbh)

UNIT SIZE	INDOOR COIL AIR		SATURATED TEMPERATURE LEAVING EVAPORATOR °F (°C)														
			35 (2)			40 (4)			45 (7)			50 (10)			55 (13)		
	CFM	EWB	TC	SHC	BF	TC	SHC	BF	TC	SHC	BF	TC	SHC	BF	TC	SHC	BF
18 / 19	525	72 (22)	38	18	0.00	35	17	0.00	31	15	0.00	27	14	0.00	22	12	0.00
		67 (19)	32	19	0.00	28	18	0.00	25	16	0.00	20	14	0.00	15	12	0.00
		62 (17)	26	20	0.00	22	18	0.00	19	17	0.01	15	15	0.07	13	13	0.21
	600	72 (22)	42	20	0.00	38	18	0.00	34	17	0.00	30	15	0.00	24	13	0.00
		67 (19)	34	21	0.00	31	19	0.00	26	17	0.00	22	16	0.00	17	14	0.01
		62 (17)	28	22	0.01	24	20	0.01	20	19	0.01	17	17	0.08	14	14	0.22
	675	72 (22)	45	21	0.00	41	20	0.00	37	18	0.00	32	16	0.00	26	14	0.00
		67 (19)	37	23	0.01	33	21	0.01	29	19	0.01	24	17	0.01	18	15	0.01
		62 (17)	30	24	0.01	26	22	0.01	22	20	0.01	19	19	0.10	16	16	0.24
24 / 25	700	72 (22)	46	22	0.00	43	20	0.00	38	19	0.00	33	17	0.00	27	15	0.00
		67 (19)	38	24	0.01	35	22	0.01	30	20	0.01	25	18	0.01	19	16	0.01
		62 (17)	31	25	0.01	27	24	0.01	23	22	0.02	20	20	0.11	17	17	0.24
	800	72 (22)	50	24	0.00	46	22	0.00	41	20	0.01	36	18	0.01	30	16	0.01
		67 (19)	41	26	0.01	37	24	0.01	32	22	0.01	27	20	0.01	21	18	0.02
		62 (17)	34	28	0.01	30	26	0.01	25	25	0.03	22	22	0.14	19	19	0.26
	900	72 (22)	53	25	0.01	48	24	0.01	44	22	0.01	38	20	0.01	32	17	0.01
		67 (19)	44	28	0.01	39	26	0.01	34	24	0.01	29	22	0.02	22	19	0.02
		62 (17)	36	30	0.02	32	28	0.02	27	27	0.05	24	24	0.16	21	21	0.28
30 / 31	875	72 (22)	67	33	0.00	61	30	0.00	54	27	0.00	46	23	0.00	37	20	0.00
		67 (19)	55	34	0.01	49	31	0.01	41	28	0.01	33	24	0.01	23	20	0.01
		62 (17)	44	35	0.01	38	32	0.01	30	28	0.01	24	24	0.07	20	20	0.23
	1000	72 (22)	74	37	0.00	67	33	0.00	59	30	0.00	50	26	0.00	40	22	0.01
		67 (19)	61	38	0.01	54	34	0.01	46	31	0.01	37	27	0.01	25	22	0.01
		62 (17)	49	39	0.01	42	35	0.01	34	31	0.02	27	27	0.08	22	22	0.24
	1100	72 (22)	79	39	0.00	72	36	0.00	63	32	0.01	54	28	0.01	43	24	0.01
		67 (19)	65	41	0.01	57	37	0.01	49	33	0.01	39	29	0.01	28	24	0.02
		62 (17)	52	42	0.02	45	38	0.02	36	34	0.02	29	29	0.09	24	24	0.25
36 / 37	1050	72 (22)	73	36	0.00	67	33	0.00	59	29	0.01	51	26	0.01	41	22	0.01
		67 (19)	60	38	0.01	54	34	0.01	46	31	0.01	37	27	0.01	27	23	0.02
		62 (17)	49	39	0.01	42	36	0.01	34	32	0.02	28	28	0.09	23	23	0.24
	1200	72 (22)	80	39	0.00	73	36	0.00	65	32	0.01	55	28	0.01	45	24	0.01
		67 (19)	66	41	0.02	58	38	0.02	50	34	0.02	41	30	0.02	30	26	0.02
		62 (17)	53	43	0.02	46	40	0.02	38	36	0.02	32	32	0.11	26	26	0.25
	1350	72 (22)	85	42	0.00	78	39	0.01	69	35	0.01	59	31	0.02	48	27	0.02
		67 (19)	71	45	0.02	63	41	0.02	54	37	0.02	44	33	0.02	32	28	0.03
		62 (17)	57	47	0.02	49	44	0.02	41	39	0.03	35	35	0.12	29	29	0.26

**CFM** – Cubic Ft per Minute

**EWB** – Entering Wet Bulb °F (°C)

**LWB** – Leaving Wet Bulb °F (°C)

**TC** – Gross Cooling Capacity 1000 Btuh

**SHC** – Gross Sensible Capacity 1000 Btuh

**BF** – Bypass Factor

**MBH** – 1000 Btuh

**NOTES:**

- Contact manufacturer for cooling capacities at conditions other than shown in table.
- Formulas:  
 Leaving db = entering db -  $\frac{\text{sensible heat cap.}}{1.09 \times \text{CFM}}$   
 Leaving wb = wb corresponding to enthalpy of air leaving coil ( $h_{lwb}$ )  
 $h_{lwb} = h_{ewb} - \frac{\text{total capacity (Btuh)}}{4.5 \times \text{CFM}}$   
 where  $h_{ewb}$  = enthalpy of air entering coil. Direct interpolation is permissible. Do not extrapolate.
- SHC is based on 80°F (27°C) db temperature of air entering coil. Below 80°F (27°C) db, subtract (Correction Factor x CFM) from SHC. Above 80°F (27°C) db, add (Correction Factor x CFM) to SHC.
- Bypass Factor = 0 indicates no psychometric solution. Use bypass factor of next lower EWB for approximation.

### SHC CORRECTION FACTOR

BYPASS FACTOR	ENTERING AIR DRY-BULB TEMPERATURE (°F)					
	79	78	77	76	75	Under 75
	81	82	83	84	85	Over 85
BYPASS FACTOR	ENTERING AIR DRY-BULB TEMPERATURE (°C)					
	26	25	25	24	24	Under 75
	27	28	28	29	29	Over 85
Correction Factor						
0.10	.098	1.96	2.94	3.92	4.91	Use formula shown below
0.20	0.87	1.74	2.62	3.49	4.36	
0.30	0.76	1.53	2.29	3.05	3.82	

Interpolation is permissible.

Correction Factor =  $1.09 \times (1 - \text{BF}) \times (\text{db} - 80)$

## PERFORMANCE DATA (CONT.)

### ESTIMATED SOUND POWER LEVEL (dBA)

UNIT SIZE	CONDITIONS		OCTAVE BAND CENTER FREQUENCY						2000	4000
	CFM	Ext Static Pressure	63	125	250	500	1000			
18, 19	600	0.25	46	52.1	48.9	51.8	52.5	51.7	49.7	
24, 25	800	0.25	54.1	57.1	58.6	59	61.5	59.8	57	
30, 31	1000	0.25	51.6	52.6	52.6	53.3	56.1	52.8	59.7	
36, 37	1200	0.25	52.6	52.3	54.6	54.3	57.2	53.8	50.4	

\* Estimated sound power levels have been derived using the method described in the 1987 ASHRAE HVAC Systems & Applications Handbook, Chapter 52, p. 52.7.

### ELECTRICAL DATA FOR FFMANP(018,024,030,036) PSC MOTOR UNITS WITH ELECTRIC HEAT

Heat Kit Model	Used on Size	Nominal Heat Capacity @ 240V	Ship-ping Weight	Heater Capacity (MBH)		Minimum Circuit Ampacity (MCA)		MAX. Fuse or Breaker Heat-Kit Ampacity (HACR)		Min Wire Size (AWG) ††		Min Ground Wire Size		Max Wire Length (Ft) ‡‡	
				KW	lbs. (kg)	208	240	208	240	208	240	208	240	208	240
EHK2-05B	018	5	5.1 (2.3)	12.3	16.4	23.6	27.1	30	30	10	10	10	10	73	74
EHK2-08B		7.5		22.2	25.6	34.9	40.1	50	50	8	8	10	10	76	77
EHK2-10B		10		24.6	32.8	46.2	53.1	60	60	6	6	10	10	92	92
EHK2-05B	024	5	5.1 (2.3)	12.3	16.4	23.9	27.3	30	30	10	10	10	10	73	73
EHK2-08B		7.5		22.2	25.6	35.2	40.4	50	50	8	8	10	10	76	76
EHK2-10B		10		24.6	32.8	46.4	53.4	60	60	6	6	10	10	91	92
EHK2-05B	030	5	5.1 (2.3)	12.3	16.4	24.2	27.7	30	30	10	10	10	10	72	72
EHK2-08B		7.5		22.2	25.6	35.5	40.7	50	50	8	8	10	10	75	76
EHK2-10B		10		24.6	32.8	46.8	53.7	60	60	6	6	10	10	91	91
EHK2-05B	036	5	5.1 (2.3)	12.3	16.4	24.9	28.3	30	30	10	10	10	10	70	71
EHK2-08B		7.5		22.2	25.6	36.2	41.4	50	50	8	8	10	10	74	74
EHK2-10B		10		24.6	32.8	47.4	54.4	60	60	6	6	10	10	90	90

\* †† Copper wire must be used. If other than uncoated (non-plated), 75°C ambient, copper wire (solid wire for 10 AWG and smaller, stranded wire for larger than 10 AWG) is used, consult applicable tables of the National electric Code (ANSI/NGPA 70).

\* ‡‡ Length shown is as measured 1 way along wire path between unit and service panel for a voltage drop not to exceed 2%.

### ELECTRICAL DATA FOR FFMANP(019,025,031,037) ECM MOTOR UNITS WITH ELECTRIC HEAT

Heat Kit Model	Used on Size	Nominal Heat Capacity @ 240V	Ship-ping Weight	Heater Capacity (MBH)		Minimum Circuit Ampacity (MCA)		MAX. Fuse or Breaker Heat-Kit Ampacity (HACR)		Min Wire Size (AWG) ††		Min Ground Wire Size		Max Wire Length (Ft) ‡‡	
				KW	lbs. (kg)	208	240	208	240	208	240	208	240	208	240
EHK2-05B	019	5	5.1 (2.3)	12.3	16.4	25	28.5	30	30	10	10	10	10	69	70
EHK2-08B		7.5		22.2	25.6	36.3	41.5	50	50	8	8	10	10	73	74
EHK2-10B		10		24.6	32.8	47.6	54.5	60	60	6	6	10	10	89	90
EHK2-05B	025	5	5.1 (2.3)	12.3	16.4	25	28.5	30	30	10	10	10	10	69	70
EHK2-08B		7.5		22.2	25.6	36.3	41.5	50	50	8	8	10	10	73	74
EHK2-10B		10		24.6	32.8	47.6	54.5	60	60	6	6	10	10	89	90
EHK2-05B	031	5	5.1 (2.3)	12.3	16.4	26	29.5	30	30	10	10	10	10	67	68
EHK2-08B		7.5		22.2	25.6	37.3	42.5	50	50	8	8	10	10	71	72
EHK2-10B		10		24.6	32.8	48.6	55.5	60	60	6	6	10	10	87	88
EHK2-05B	037	5	5.1 (2.3)	12.3	16.4	26	29.5	30	30	10	10	10	10	67	68
EHK2-08B		7.5		22.2	25.6	37.3	42.5	50	50	8	8	10	10	71	72
EHK2-10B		10		24.6	32.8	48.6	55.5	60	60	6	6	10	10	87	88

\* †† Copper wire must be used. If other than uncoated (non-plated), 75°C ambient, copper wire (solid wire for 10 AWG and smaller, stranded wire for larger than 10 AWG) is used, consult applicable tables of the National electric Code (ANSI/NGPA 70).

\* ‡‡ Length shown is as measured 1 way along wire path between unit and service panel for a voltage drop not to exceed 2%.

## OTHER ACCESSORIES

Kit Number	Description	Used on sizes
KFBLG0106LGL	Louvered Wall Panel with Frame (6 pack)	18, 19, 24, 25
KFBLG0206LGL	Louvered Wall Panel with Frame (6 pack)	30, 31, 36, 37
KSATX0601HSO	TXV Kit R-22	All
KSATX201PUR	TXV Kit Puron (R-410A)	18, 19, 24, 25, 30, 31
KSATX301PUR	TXV Kit Puron (R-401A)	36, 37
KFAET0150ETK	PVC Condensate Trap Kit (50 pack)	All
KFARA0110LGL	Return Air Opening Grille (10 pack)	18, 19, 24, 25
KFARA0210LGL	Return Air Opening Grille (10 pack)	30, 31, 36, 37