



Installation Guide

Electric Heater Kits

Oxbox Light Commercial Rooftops

7.5 to 12.5 Tons

Model Numbers:

JAYHTMA310A	JAYHTMA414A
JAYHTMA315A	JAYHTMA416A
JAYHTMA325A	JAYHTMA425A
JAYHTMA332A	JAYHTMA433A
JAYHTMA341A	JAYHTMA441A
JAYHTMA350A	JAYHTMA450A

⚠ SAFETY WARNING

Only qualified personnel should install and service the equipment. The installation, starting up, and servicing of heating, ventilating, and air-conditioning equipment can be hazardous and requires specific knowledge and training. Improperly installed, adjusted or altered equipment by an unqualified person could result in death or serious injury. When working on the equipment, observe all precautions in the literature and on the tags, stickers, and labels that are attached to the equipment.

Introduction

Read this manual thoroughly before operating or servicing this unit.

Warnings, Cautions, and Notices

Safety advisories appear throughout this manual as required. Your personal safety and the proper operation of this machine depend upon the strict observance of these precautions.

The three types of advisories are defined as follows:



WARNING

Indicates a potentially hazardous situation which, if not avoided, could result in death or serious injury.



CAUTION

Indicates a potentially hazardous situation which, if not avoided, could result in minor or moderate injury. It could also be used to alert against unsafe practices.

NOTICE

Indicates a situation that could result in equipment or property-damage only accidents.

Important Environmental Concerns

Scientific research has shown that certain man-made chemicals can affect the earth's naturally occurring stratospheric ozone layer when released to the atmosphere. In particular, several of the identified chemicals that may affect the ozone layer are refrigerants that contain Chlorine, Fluorine and Carbon (CFCs) and those containing Hydrogen, Chlorine, Fluorine and Carbon (HCFCs). Not all refrigerants containing these compounds have the same potential impact to the environment. Oxbox advocates the responsible handling of all refrigerants-including industry replacements for CFCs and HCFCs such as saturated or unsaturated HFCs and HCFCs.

Important Responsible Refrigerant Practices

Oxbox believes that responsible refrigerant practices are important to the environment, our customers, and the air conditioning industry. All technicians who handle refrigerants must be certified according to local rules. For the USA, the Federal Clean Air Act (Section 608) sets forth the requirements for handling, reclaiming, recovering and recycling of certain refrigerants and the equipment that is used in these service procedures. In addition, some states or municipalities may have additional requirements that must also be adhered to for responsible management of refrigerants. Know the applicable laws and follow them.

⚠ WARNING

Proper Field Wiring and Grounding Required!

Failure to follow code could result in death or serious injury.

All field wiring **MUST** be performed by qualified personnel. Improperly installed and grounded field wiring poses **FIRE** and **ELECTROCUTION** hazards. To avoid these hazards, you **MUST** follow requirements for field wiring installation and grounding as described in **NEC** and your local/state/national electrical codes.

⚠ WARNING

Personal Protective Equipment (PPE) Required!

Failure to wear proper PPE for the job being undertaken could result in death or serious injury. Technicians, in order to protect themselves from potential electrical, mechanical, and chemical hazards, **MUST** follow precautions in this manual and on the tags, stickers, and labels, as well as the instructions below:

- Before installing/servicing this unit, technicians **MUST** put on all PPE required for the work being undertaken (Examples; cut resistant gloves/sleeves, butyl gloves, safety glasses, hard hat/bump cap, fall protection, electrical PPE and arc flash clothing). **ALWAYS** refer to appropriate Safety Data Sheets (SDS) and OSHA guidelines for proper PPE.
- When working with or around hazardous chemicals, **ALWAYS** refer to the appropriate SDS and OSHA/GHS (Global Harmonized System of Classification and Labelling of Chemicals) guidelines for information on allowable personal exposure levels, proper respiratory protection and handling instructions.
- If there is a risk of energized electrical contact, arc, or flash, technicians **MUST** put on all PPE in accordance with OSHA, NFPA 70E, or other country-specific requirements for arc flash protection, **PRIOR** to servicing the unit. **NEVER PERFORM ANY SWITCHING, DISCONNECTING, OR VOLTAGE TESTING WITHOUT PROPER ELECTRICAL PPE AND ARC FLASH CLOTHING. ENSURE ELECTRICAL METERS AND EQUIPMENT ARE PROPERLY RATED FOR INTENDED VOLTAGE.**

⚠ WARNING

Follow EHS Policies!

Failure to follow instructions below could result in death or serious injury.

- All Oxbox personnel must follow the company's Environmental, Health and Safety (EHS) policies when performing work such as hot work, electrical, fall protection, lockout/tagout, refrigerant handling, etc. Where local regulations are more stringent than these policies, those regulations supersede these policies.
- Non-Oxbox personnel should always follow local regulations.

Copyright

This document and the information in it are the property of Oxbox, and may not be used or reproduced in whole or in part without written permission. Oxbox reserves the right to revise this publication at any time, and to make changes to its content without obligation to notify any person of such revision or change.

Trademarks

All trademarks referenced in this document are the trademarks of their respective owners.

Pre-Installation

Unit Inspection

To protect against loss due to damage incurred in transit, perform inspection immediately upon receipt of the unit.

Exterior Inspection

If the job site inspection reveals damage or material shortages, file a claim with the carrier immediately. Specify the type and extent of the damage on the bill of lading before signing. Notify the appropriate sales representative.

Important: Do not proceed with installation of a damaged unit without sales representative's approval.

- Inspect the complete exterior for signs of shipping damages to unit or packing material.
- Verify that the nameplate data matches the sales order and bill of lading.
- Verify that the unit is properly equipped and there are no material shortages.
- Verify the power supply complies with the unit nameplate specifications.

Inspection for Concealed Damage

Inspect the components for concealed damage as soon as possible after delivery and before it is stored.

If concealed damage is discovered:

- Notify the carrier's terminal of the damage immediately by phone and by mail.
- Concealed damage must be reported within 15 days.
- Request an immediate, joint inspection of the damage with the carrier and consignee.
- Stop unpacking the unit.
- Do not remove damaged material from receiving location.
- Take photos of the damage, if possible.
- The owner must provide reasonable evidence that the damage did not occur after delivery.

Parts List

- Heater elements
- Heater control assembly (including power supply and control)
- Wiring diagrams
- Screws ANSI/B-4.8*16 (16 PCS)
- Screws ANSI/B-3.9*20(4 PCS)
- Cable ties
- Terminal block(1 PCS)
- Waterproof boxes(3 PCS)

Important:

- The 41kW heater consists one (1) 16kW and one (1) 25 kW element.
- The 32kW heater consists of two (2) 16kW elements.
- The 50kW heater consists of two (2) 25kW elements.

Main Components

Figure 1. Electric heater



Figure 2. Control assembly



Figure 3. Wiring diagram, screws, and cable ties



Figure 4. Support plates



Electric Heaters

These installation instructions apply to the following heater models:

Electric Heater Models	Nominal kW Rating
208/230 Volts Three Phase	
JAYHTMA310A	10.4
JAYHTMA315A	16.0
JAYHTMA325A	25.0
JAYHTMA332A	32.0
JAYHTMA341A	41.0
JAYHTMA350A	50.0
460 Volts Three Phase	
JAYHTMA414A	13.9
JAYHTMA416A	16.5
JAYHTMA425A	25.0
JAYHTMA433A	33.0
JAYHTMA441A	41.5
JAYHTMA450A	50.0

General Information

ALL phases of this installation must comply with NATIONAL, STATE AND LOCAL CODES. Installer must mark unit nameplate with heater information per instructions on nameplate.

Table 1. Limit control settings

Unit Model Number	Horizontal (mm)
208/230 Volts Three Phase	
J4PRC4090	1000
J4PRC4102	1000
J4PRC4120	1000
J4PRC5150	1000
460 Volts Three Phase	
J4PRC4090	1000
J4PRC4102	1000
J4PRC4120	1000
J4PRC5150	1000

Table 2. Air temperature rise across electric heaters (°F)

kW	Stages	10 Ton 4000 cfm	7.5 Ton 3000 cfm	8.5 Ton 3400 cfm	12.5 Ton 5000 cfm
208/230 Volts Three Phase (°F)					
10.4	1	8.2	10.7	9.9	6.8
16.0	1	12.6	14.6	13.8	10.9
25.0	1	-	22.4	22.4	-
32.0	2	25.3	28.2	27.1	22.9
41.0	2	32.4	37.5	35.6	30.1
50.0	2	39.5	-	-	37.0
460 Volts Three Phase (°F)					
13.9	1	10.5	12.4	11.8	8.7
16.5	1	13.1	15.0	14.4	11.3
25.0	1	-	22.4	22.4	-
33.0	2	26.2	29.2	28.3	22.5
41.5	2	33.0	38.2	36.1	28.2
50.0	2	39.5	-	-	33.8

Table 3. Unit wiring with electric heat (single point connection)

TONS	Unit Model Number	Heater kW Rating	Control Stages	Standard Indoor Fan Motor		Oversized Indoor Fan Motor	
				Minimum Circuit Ampacity	Maximum Fuse Size or Maximum Circuit Breaker	Minimum Circuit Ampacity	Maximum Fuse Size or Maximum Circuit Breaker
208/230 Volts Three Phase							
7.5	JAYHTMA341A	41.0	2	116/133	125/150	122/139	125/150
	JAYHTMA332A	32.0	2	93/106	100/110	99/112	100/125
	JAYHTMA325A	25.0	1	75/85	80/90	81/91	90/100
	JAYHTMA315A	16.0	1	51/58	60	57/64	60/70
	JAYHTMA310A	10.4	1	37/41	45	43/47	50
8.5	JAYHTMA341A	41.0	2	116/133	125/150	126/142	150
	JAYHTMA332A	32.0	2	93/106	100/110	102/115	110/125
	JAYHTMA325A	25.0	1	75/85	80/90	84/94	90/100
	JAYHTMA315A	16.0	1	51/58	60	60/67	60/70
	JAYHTMA310A	10.4	1	42	50	49/50	60
10	JAYHTMA350A	50.0	2	146/136	150	149/139	150
	JAYHTMA341A	41.0	2	122/139	125/150	126/142	150
	JAYHTMA332A	32.0	2	99/112	100/125	102/115	100/125
	JAYHTMA315A	16.0	1	57/64	70	60/67	70
	JAYHTMA310A	10.4	1	54	70	57	70
12.5	JAYHTMA350A	50.0	2	146/136	150	149/139	150
	JAYHTMA341A	41.0	2	122/139	125/150	126/142	150
	JAYHTMA332A	32.0	2	99/112	100/125	102/115	110/125
	JAYHTMA315A	16.0	1	66	80	69	90
	JAYHTMA310A	10.4	1	66	80	69	90
460 Volts Three Phase							
7.5	JAYHTMA441A	41.5	2	70	70	76	80
	JAYHTMA433A	33.0	2	57	60	63	70
	JAYHTMA425A	25.0	1	44	45	50	50
	JAYHTMA416A	16.5	1	31	35	37	40
	JAYHTMA414A	13.9	1	27	30	33	35
8.5	JAYHTMA441A	41.5	2	70	70	78	80
	JAYHTMA433A	33.0	2	57	60	65	70
	JAYHTMA425A	25.0	1	44	45	52	60
	JAYHTMA416A	16.5	1	31	35	39	40
	JAYHTMA414A	13.9	1	27	30	35	40
10	JAYHTMA450A	50.0	2	74	80	76	80
	JAYHTMA441A	41.5	2	76	80	78	80
	JAYHTMA433A	33.0	2	63	70	65	70
	JAYHTMA416A	16.5	1	37	40	39	40
	JAYHTMA414A	13.9	1	33	35	35	40
12.5	JAYHTMA450A	50.0	2	74	80	76	80
	JAYHTMA441A	41.5	2	76	80	78	80
	JAYHTMA433A	33.0	2	63	70	65	70
	JAYHTMA416A	16.5	1	37	40	39	45
	JAYHTMA414A	13.9	1	34	40	35	45

Installation

⚠ WARNING

Hazardous Voltage w/Capacitors!

Failure to disconnect power and discharge capacitors before servicing could result in death or serious injury.

Disconnect all electric power, including remote disconnects and discharge all motor start/run capacitors before servicing. Follow proper lockout/tagout procedures to ensure the power cannot be inadvertently energized. For variable frequency drives or other energy storing components provided by Oxbox or others, refer to the appropriate manufacturer's literature for allowable waiting periods for discharge of capacitors. Verify with a CAT III or IV voltmeter rated per NFPA 70E that all capacitors have discharged.

Important: Turn off power to unit. Follow proper lockout/tagout procedures to ensure power cannot inadvertently be energized.

The figure shown in this manual is for reference only and may be slightly different from the actual product.

1. Remove access panels A B and C. Refer to the following figure. Retain screws for future use.

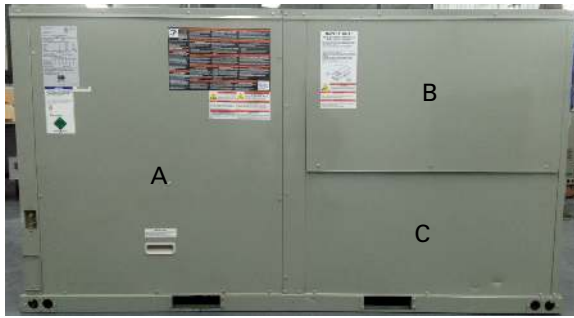

2. Remove duct access panel D. Refer to the following figure. Retain screws for future use.

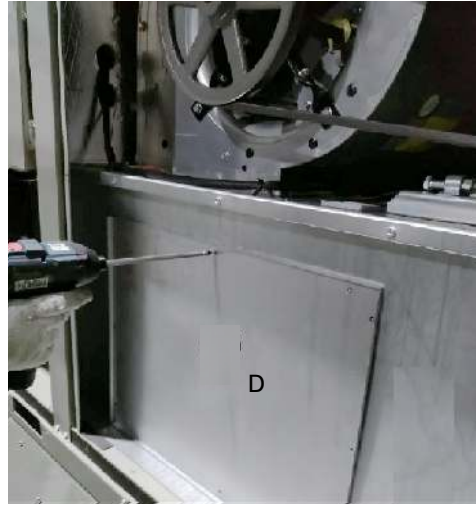

3. Install the electric heaters support plate to the base of unit. Both ends of the support plate must be secured to the bottom panel, using provided screws. Refer to the following figure.



4. Check the opening in the panel. Remove any metal burrs or slivers that could damage or pinch the heater elements resulting in a short circuit when elements are installed in the opening.

5. Slide control assembly in. Secure to panel D hole. Use retained screws from step 2. Refer to the following figures.
6. Slide electric heater in. Secure to control assembly hole. Use new screws. Refer to the following figure.

Figure 5. Electric heater aligned to screw holes



7. Connect the electric heater power wire to the contactor, fix the wire with the cable tie. Connect the temperature protection switch wire. Refer to the following figure.

Figure 6. Electric heater wiring



8. Secure guard panel with wire hook. Refer to the following figure.



9. Install rubber ring. Refer to the following figure.



10. Cutoff the cable tie as shown by the arrow below, Pass the signal wire through the upper wire passing rubber ring and the power wire through the lower wire passing rubber ring. Fasten the wire passing rubber ring with cable tie. Refer to the following figures.



Installation



11. Install the waterproof box, and then fix the wire with the cable tie.
Refer to the following figure.



12. Remove the cover E and F from the electric control box. Refer to the following figures.

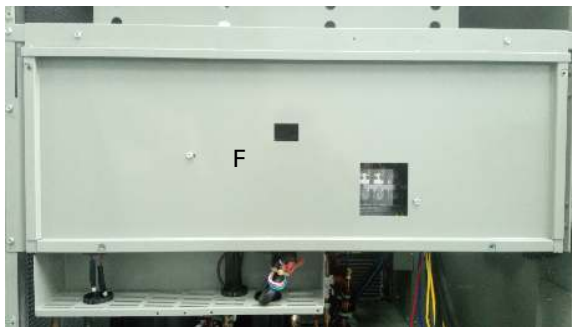
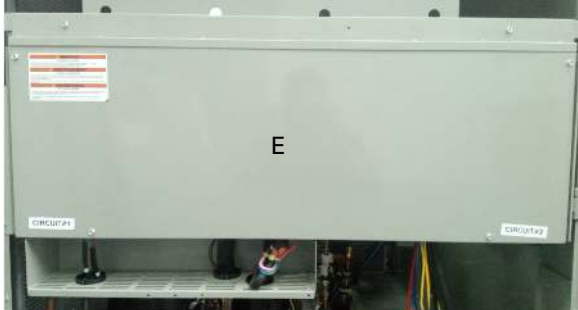

13. Install the new terminal block(XT2).

For 208/230V model

Disconnect the power supply wires for the fuse and contactor to COMP-B from XT1, and connect them (the power supply wire for the fuse and COMP-B which disconnect from XT1) to the new installed terminal XT2, other wires keep same as before. At the same time, reinstall the W phase power line of COMP-B to the L3 terminal of the new terminal block.

For 460V model

Disconnect the power supply wires for the fuse from XT1, and connect them (the power supply wire for the fuse which disconnect from XT1) to the new installed terminal XT2, other wires keep same as before.



14. Connect the power wires from the single point box to the unit's power terminal block XT1 and XT2.
Please note the phase sequence color of the wires.

15. Connect the heater control wiring to Socket CN26 on the mainboard.



16. Fix the wire with cable ties.



17. Mark the appropriate block on the unit nameplate for the accessory heater kW installed. Note the required Minimum Circuit Ampacity(MCA) value for this unit—heater combination. Ensure the field power conductors are sized to handle this ampacity. Check also that the unit disconnect size and the overcurrent protection device for the branch circuit conductors are suitable for this unit—heater combination.
18. Run wire through conduit connecting outside power to the designated terminals at the top of the single point box. Ground appropriately.

Wiring Diagram-230V

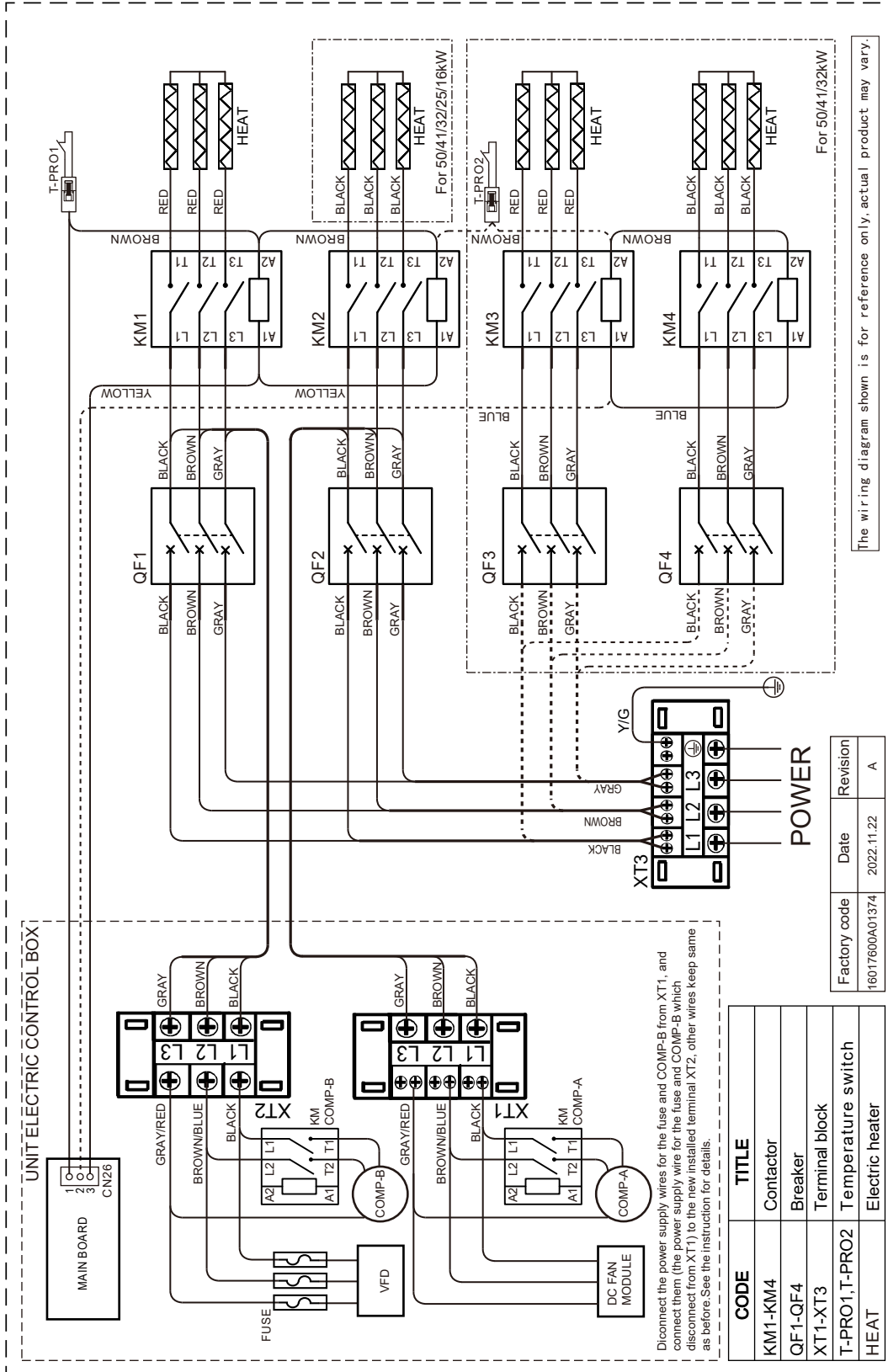

The wiring diagram shown is for reference only, actual product may vary.

Factory code	Date	Revision
16017600A01374	2022.11.22	A

CODE	TITLE
KM1-KM4	Contactors
QF1-QF4	Breakers
XT1-XT3	Terminal block
T-PRO1, T-PRO2	Temperature switch
HEAT	Electric heater

Wiring Diagram-460V

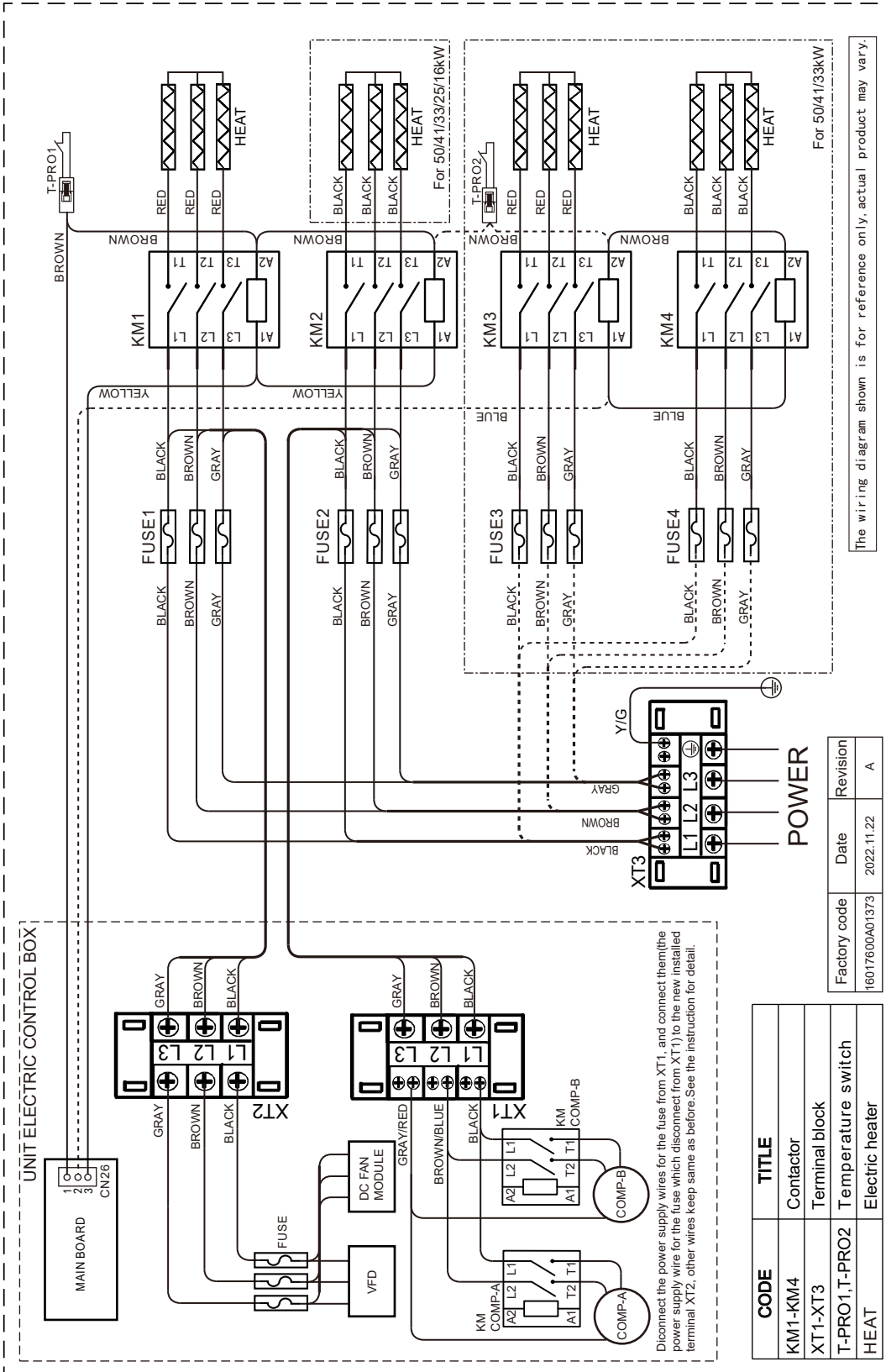

TwentyThreeC, LLC
800 Beaty Street,
Davidson, NC, 28036
www.oxboxhvac.com

For more information contact
your local dealer (distributor)

RT-SVN036A-ENB 20 Dec 2022
Supersedes (New)
16126000A27384 V.A



Since the manufacturer has a policy of continuous product and product data improvement, it reserves the right to change the design and specification without notice.

© . 2019 TwentyThreeC, LLC