



**Select** series

## Versus™ Line Gas Furnaces



### **W801T UH**

80% A.F.U.E.†

Heating Stages: Single Stage

Motor Type: Constant Torque

Input Rates: 50-125 kBTU [14.6-36.6 kW]

Configuration Options: Upflow/Horizontal



† A.F.U.E. (Annual Fuel Utilization Efficiency) calculated in accordance with Department of Energy test procedures.

## Table of Contents

Features & Benefits .....	3
Model Number Identification .....	4
Physical Data and Specifications .....	5
Dimensional Data .....	6-7
Blower Performance Data .....	8
Accessories .....	9
Limited Warranty .....	12

## Features and Benefits

- **Diagnostics:** Industry-first, 7-segment LED for quick & easy service
- **Ignition System:** Proven Direct Spark Ignition (DSI) for reliability and longevity
- **Low Profile, 34-inch Cabinet:** Makes our furnaces ideal for space-constrained installations
- **Hemmed Cabinet & Door Edges and Quarter-Turn Door Fasteners (Upflow/Horizontal only):** Allows for safe, tool-less access and serviceability
- **Removable Heat Exchanger:** Improves serviceability. Aluminized steel construction provides maximum corrosion resistance and thermal fatigue reliability

# Gas Furnaces

<u>W</u>	<u>80</u>	<u>1</u>	<u>T</u>	<u>050</u>	<u>3</u>	<u>A</u>	<u>14</u>	<u>UH</u>	<u>S</u>	<u>N</u>	<u>A</u>	<u>S</u>
Brand	Furnace Efficiency	Stages of Heating	Motor Type	Heating Input	AC Max. Capacity	Major Series	Width	Position	NOx	Controls	Minor Series	Option Code
R - Rheem Select	80 - 80% AFUE	1 - Single-Stage	T - Constant Torque	050 - 50K BTUH [14.7 kW] 075 - 75K BTUH [22.0 kW] 100 - 100K BTUH [29.3 kW] 125 - 125K BTUH [36.6 kW]	3 - 3 ton drive 4 - 4 ton drive 5 - 5 ton drive	A - 1st Design Series	14 - 14" 17 - 17.5" 21 - 21" 24 - 24.5"	UH - Upflow Horizontal	S - Standard N - Low NOx	N - Non-Communicating	A - 1st Series	S - Standard Grade

[ ] Designates Metric Conversions

AVAILABLE MODELS
R801T0503A14UHSNAS
R801T0754A17UHSNAS
R801T0754A21UHSNAS
R801T1005A21UHSNAS
R801T1255A24UHSNAS
R801T0503A14UHNNAS
R801T0754A17UHNNAS
R801T0754A21UHNNAS
R801T1005A21UHNNAS

STANDARD EQUIPMENT
Limit controls
Manual shut-off valve
100% safety lock out
Cool fan off delay
Field selectable heat fan off delay
One hour automatic retry
Power and self test diagnostics
Flame sense current diagnostics
Electronic air cleaner connections
Twinning (built-in) features
Humidifier connections
Low speed continuous fan option
Single speed option for heating and cooling applications
Transformer
Direct drive motor
Multi-speed constant torque blower motor

**WARNING**  
 THIS FURNACE IS NOT APPROVED  
 OR RECOMMENDED  
 FOR USE IN MOBILE HOMES

## Physical Data and Specifications—Upflow Models

MODEL NUMBERS W801T UH	R801T0503A14UH*NAS	R801T0754A17UH*NAS	R801T0754A21UH*NAS	R801T1005A21UH*NAS	R801T1255A24UH*NAS
<b>Constant Tq-UH Series</b>					
Input-BTU/Hr [kW]	50,000 [15]	75,000 [22]	75,000 [22]	100,000 [29]	125,000 [37]
Heating Capacity BTU/Hr [kW] ©	40,000 [12]	60,000 [18]	60,000 [18]	80,000 [23]	100,000 [29]
Heat Ext. Static Pressure [kPa]	.18 [.05]	.20 [.05]	.20 [.05]	.28 [.07]	.28 [.07]
Blower (D x W) [mm]	11 x 6 [279 x 152]	11 x 7 [279 x 178]	11 x 7 [279 x 178]	11 x 10 [279 x 254]	11 x 10 [279 x 254]
Motor H.P. [W] Type	1/2 [373] 5 Spd Constant Torque	1/2 [373] 5 Spd Constant Torque	3/4 [560] 5 Spd Constant Torque	3/4 [560] 5 Spd Constant Torque	3/4 [560] 5 Spd Constant Torque
Min. Circuit Ampacity	8	8	9	10	11
Min. Overload Protection Device	15	15	15	15	15
Max. Overload Protection Device	15	15	15	15	15
Heating Speed	Med	Med	Med-High	Med	Med-High
Cooling Speed	High	High	High	High	High
Cooling CFM @ Rating Point [L/s]	1305 [616]	1402 [662]	1608 [759]	1840 [868]	1934 [913]
Max. E.S.P. (In. W.C.) [kPa]	0.9 [.22]	0.9 [.22]	0.9 [.22]	0.9 [.22]	0.9 [.22]
Temperature Rise Range °F [°C]	25-55 [13.9-30.6]	25-55 [13.9-30.6]	25-55 [13.9-30.6]	40-70 [22-39]	35-65 [19.4-36.1]
Max. Outlet Air Temp. °F [°C]	155 [68.3]	155 [68.3]	160 [71.1]	180 [82.2]	165 [73.8]
Approx. Shipping Weight (Lbs.) [kg]	110 [50]	125 [57]	140 [64]	140 [64]	150 [68]
AFUE ©	80.00%	80.00%	80.00%	80.00%	80.00%

NOTES: All models are 115V, 60HZ, 1 Ph. Gas connection size for all models is 1/2" [12 mm] N.P.T.

© In accordance with D.O.E. test procedures.

© See Conversion Kit Index Form for high altitude derate.

\*S=Standard, N=Low NOx

This furnace does not meet air district requirements of 14 ng/J NOx emissions limit. This furnace is not eligible for the Clean Air Furnace Rebate Program: [www.CleanAirFurnaceRebate.com](http://www.CleanAirFurnaceRebate.com).

This furnace is to be installed for propane firing only in air districts requiring 14 ng/J NOx emission limits. Operating in natural gas mode is in violation of these Rules.

[ ] Designates Metric Conversions

## Upflow Application

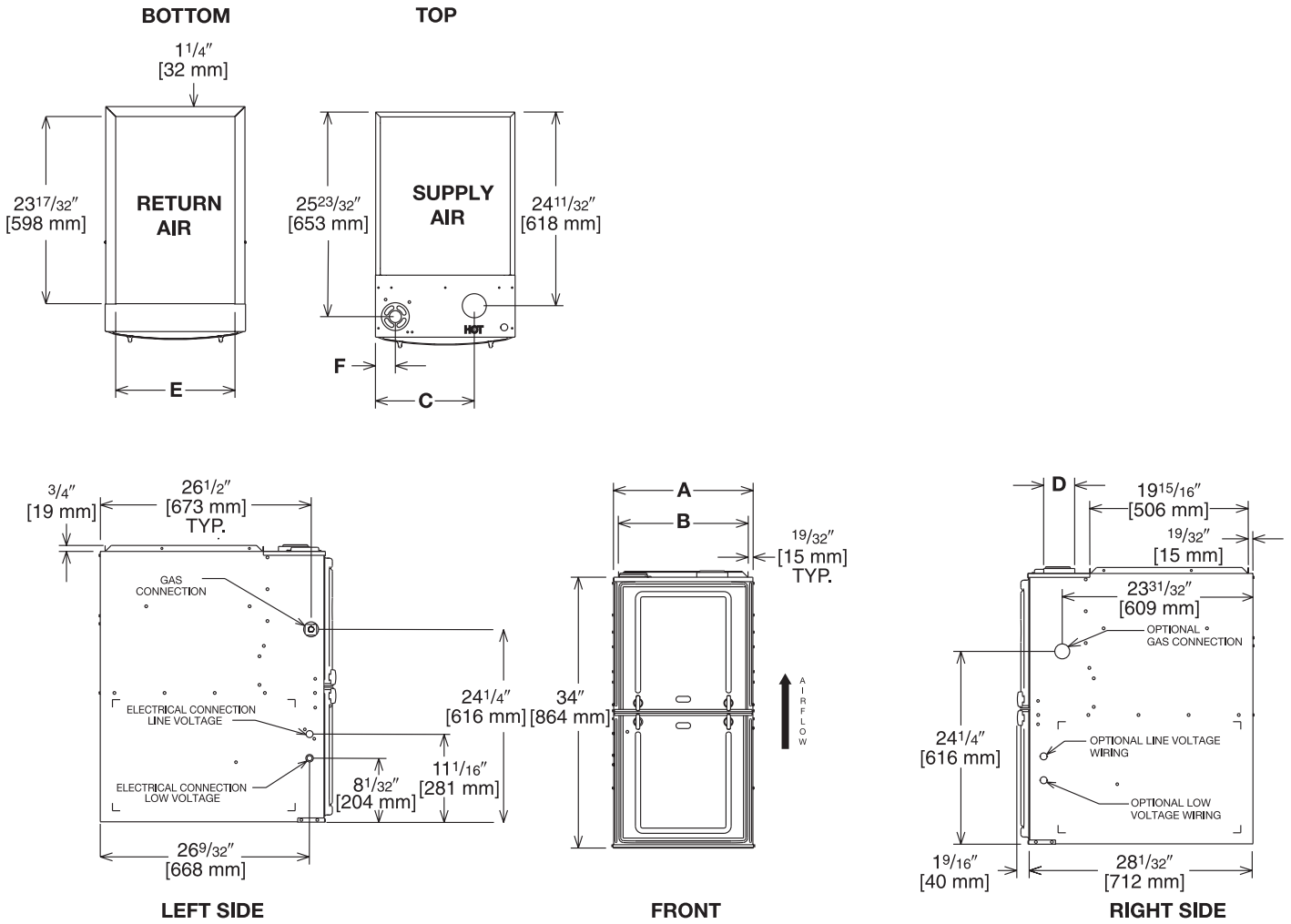

Illustration  
ST-A1220-04-00  
FIGURE 1

## Dimensional Data: Upflow Model

MODEL W801T UH	A	B	C	D	E	F	MINIMUM CLEARANCE (IN.) [mm]					SHIP WGTS. (LBS.) [kg]	
							LEFT SIDE	RIGHT SIDE	BACK	TOP	FRONT		VENT
050	14 [356]	$12\frac{27}{32}$ [326]	$10\frac{5}{8}$ [270]	①	$11\frac{1}{2}$ [292]	$1\frac{7}{8}$ [48]	0	4 [102] ②	0	1 [25]	3 [76]	6 [152] ③	110 [50]
0754A17	$17\frac{1}{2}$ [445]	$16\frac{11}{32}$ [415]	$12\frac{3}{8}$ [314]	①	15 [381]	$2\frac{1}{2}$ [64]	0	3 [76] ②	0	1 [25]	3 [76]	6 [152] ③	125 [57]
0754A21/100	21 [533]	$19\frac{27}{32}$ [504]	$14\frac{1}{8}$ [359]	①	$18\frac{1}{2}$ [470]	$2\frac{1}{2}$ [64]	0	0	0	1 [25]	3 [76]	6 [152] ③	140 [64]
125	$24\frac{1}{2}$ [622]	$23\frac{11}{32}$ [593]	$15\frac{7}{8}$ [403]	①	22 [559]	$2\frac{1}{2}$ [64]	0	0	0	1 [25]	3 [76]	6 [152] ③	150 [68]

NOTES: ① May require a 3" [76 mm] to 4" [102 mm] or 3" [76 mm] to 5" [127 mm] adapter.

② May be 0" [0 mm] with type B vent.

③ May be 1" [25 mm] with type B vent.

Furnaces must be vented in accordance with the National Fuel Gas Code, ANSI Z223.1 and in accordance with local codes.

[ ] Designates Metric Conversions

## Horizontal Application

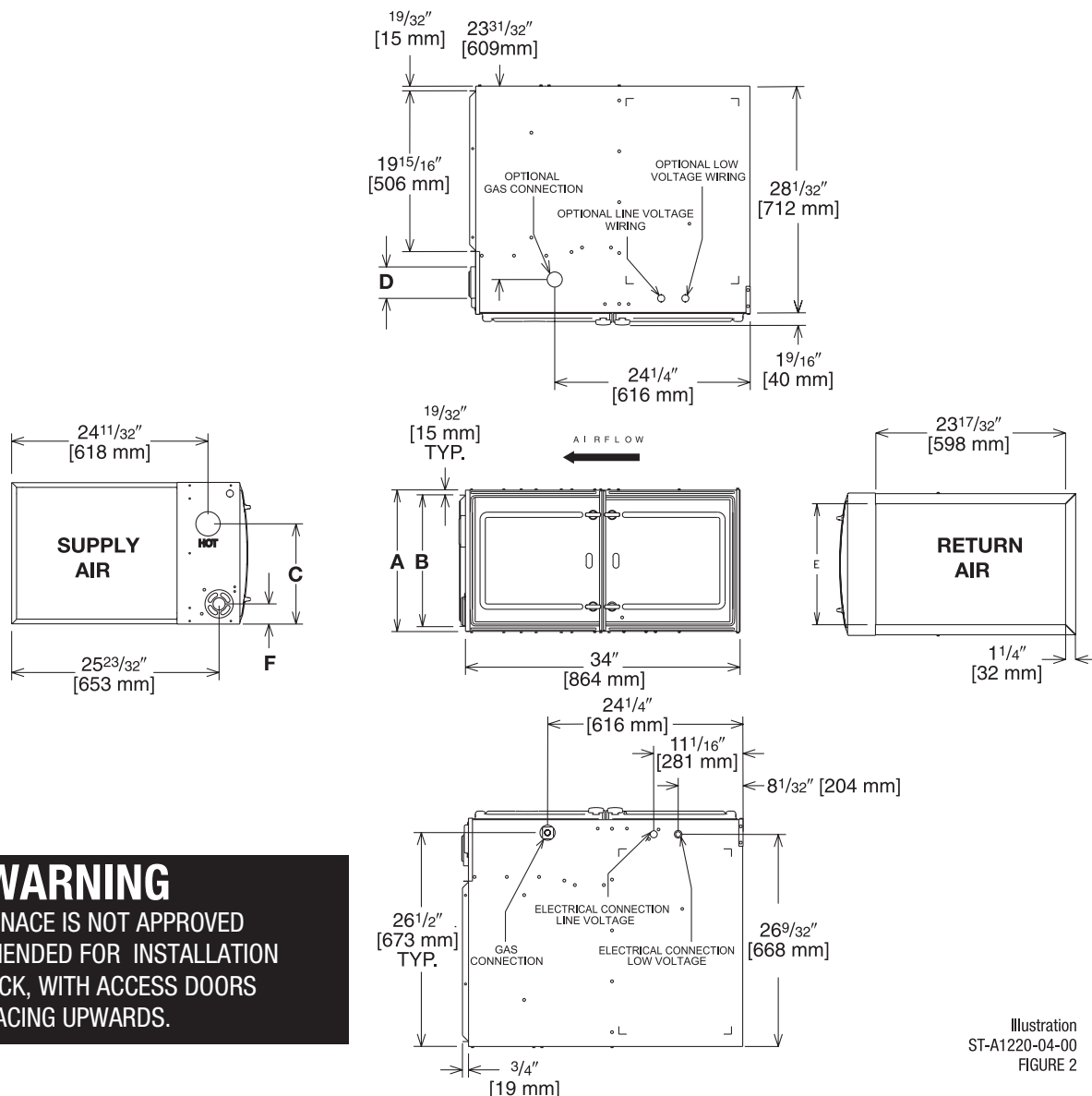

**WARNING**  
THIS FURNACE IS NOT APPROVED  
OR RECOMMENDED FOR INSTALLATION  
ON ITS BACK, WITH ACCESS DOORS  
FACING UPWARDS.

Illustration  
ST-A1220-04-00  
FIGURE 2

## Dimensional Data: Horizontal Model

MODEL R801T UH	A	B	C	D	E	F	MINIMUM CLEARANCE (IN.) [mm]						SHIP WGTS. (LBS.) [kg]
							SUPPLY AIR SIDE	RETURN AIR SIDE	BACK	TOP	FRONT	VENT	
050	14 [356]	12 <sup>27</sup> / <sub>32</sub> [326]	10 <sup>5</sup> / <sub>8</sub> [270]	①	11 <sup>1</sup> / <sub>2</sub> [292]	17 <sup>8</sup> / <sub>8</sub> [48]	4 [102] ②	4 [102] ②	0	1 [25]	3 [76]	6 [152] ③	110 [50]
0754A17	17 <sup>1</sup> / <sub>2</sub> [445]	16 <sup>11</sup> / <sub>32</sub> [415]	12 <sup>3</sup> / <sub>8</sub> [314]	①	15 [381]	2 <sup>1</sup> / <sub>2</sub> [64]	3 [76] ②	3 [76] ②	0	1 [25]	3 [76]	6 [152] ③	125 [57]
0754A21/100	21 [533]	19 <sup>27</sup> / <sub>32</sub> [504]	14 <sup>1</sup> / <sub>8</sub> [359]	①	18 <sup>1</sup> / <sub>2</sub> [470]	2 <sup>1</sup> / <sub>2</sub> [64]	0	0	0	1 [25]	3 [76]	6 [152] ③	140 [64]
125	24 <sup>1</sup> / <sub>2</sub> [622]	23 <sup>11</sup> / <sub>32</sub> [593]	15 <sup>7</sup> / <sub>8</sub> [403]	①	22 [559]	2 <sup>1</sup> / <sub>2</sub> [64]	0	0	0	1 [25]	3 [76]	6 [152] ③	150 [68]

NOTES: ① May require a 3" [76 mm] to 4" [102 mm] or 3" [76 mm] to 5" [127 mm] adapter.

② May be 0" [0 mm] with type B vent.

③ May be 1" [25 mm] with type B vent.

Furnaces must be vented in accordance with the National Fuel Gas Code, ANSI Z223.1 and in accordance with local codes.

[ ] Designates Metric Conversions

## Blower Performance Data

AIRFLOW PERFORMANCE - 80% SINGLE STAGE DOWNFLOW CONSTANT TORQUE												
INPUT [BTU] CABINET WIDTH [IN]	AIRFLOW CONTROL SETTINGS	SPEED TAP/ WIRE COLORS	CFM AIR DELIVERY EXTERNAL STATIC PRESSURE INCHES WATER COLUMN									
			0.1	0.2	0.3	0.4	0.5	0.6	0.7	0.8	0.9	1.0
50K 14"	Factory Setting Fan	Low/Red	909	747	618	517	439	377	326	280	234	183
	Cool	Medium Low/ Yellow	982	899	828	766	712	664	620	577	534	490
	Heat or Heat/Cool	Medium/ Purple	1027	993	958	921	882	843	802	762	721	680
	Cool	Medium High/ Blue	1172	1130	1093	1060	1030	1001	972	941	907	869
	Factory Setting Cooling	High/Black	1296	1262	1232	1204	1177	1150	1123	1094	1063	1029
75K 17"	Factory Setting Fan	Low/Red	1018	957	913	866	816	772	720	670	626	588
	Heat or Heat/Cool	Medium Low/ Yellow	1146	1111	1059	1012	967	928	889	845	800	755
	Cool	Medium/ Purple	1325	1257	1199	1144	1089	1028	975	922	871	813
	Cool	Medium High/ Blue	1554	1490	1429	1365	1306	1272	1218	1170	1122	1077
	Factory Setting Cooling	High/Black	1752	1682	1625	1574	1525	1473	1421	1379	1341	1296
75K 21"	Factory Setting Fan	Low/Red	1011	987	928	861	796	739	675	604	553	513
	Cool	Medium Low/ Yellow	1341	1287	1216	1162	1105	1054	1000	952	899	847
	Heat or Heat/Cool	Medium/ Purple	1535	1487	1434	1384	1333	1280	1230	1190	1142	1099
	Cool	Medium High/ Blue	1689	1644	1596	1559	1499	1454	1414	1370	1331	1280
	Factory Setting Cooling	High/Black	1848	1801	1762	1717	1678	1632	1598	1556	1527	1470
100K 21"	Factory Setting Fan	Low/Red	1123	1035	968	897	838	768	692	618	570	525
	Cool	Medium Low/ Yellow	1421	1365	1316	1266	1219	1157	1105	1052	1004	959
	Cool	Medium/ Purple	1684	1632	1744	1549	1506	1462	1421	1379	1333	1277
	Heat or Heat/Cool	Medium High/ Blue	1865	1825	1780	1747	1705	1677	1636	1597	1562	1499
	Factory Setting Cooling	High/Black	1997	1955	1916	1875	1841	1803	1769	1730	1700	1646
125K 24"	Factory Setting Fan	Low/Red	1127	1064	993	931	867	805	749	687	628	578
	Cool	Medium Low/ Yellow	1438	1381	1330	1277	1227	1171	1118	1061	1024	976
	Cool	Medium/ Purple	1726	1664	1622	1588	1544	1494	1446	1404	1360	1317
	Heat or Heat/Cool	Medium High/ Blue	1883	1832	1789	1756	1711	1678	1617	1587	1551	1495
	Factory Setting Cooling	High/Black	2209	2166	2129	2090	2059	2010	1976	19144	1911	1875

**BOTTOM RETURN FILTER RACK FOR  
UPFLOW APPLICATION: RXGF-CB**

**SIDE RETURN FILTER RACK: RXGF-CD**

FILTER RACK FILTER SIZES* INCHES [mm]		
MODEL	RXGF-CB (UPFLOW/ HORIZONTAL)	RXGF-CD (UPFLOW) SIDE RETURN
R801T050	12 <sup>1</sup> / <sub>4</sub> x 25 [311 x 635]	15 <sup>3</sup> / <sub>4</sub> x 25 [400 x 635]
R801T0503A17	15 <sup>3</sup> / <sub>4</sub> x 25 [400 x 635]	15 <sup>3</sup> / <sub>4</sub> x 25 [400 x 635]
R801T0755A21/ R801W100	19 <sup>1</sup> / <sub>4</sub> x 25 [489 x 635]	15 <sup>3</sup> / <sub>4</sub> x 25 [400 x 635]
R801T125	22 <sup>3</sup> / <sub>4</sub> x 25 [578 x 635]	15 <sup>3</sup> / <sub>4</sub> x 25 [400 x 635]

**4" FLUE ADAPTER: RXGW-C01**

**Indoor Coil Casings**

MODEL NUMBER
RXBC-D14AI
RXBC-D17AI
RXBC-D21AI
RXBC-D21BI
RXBC-D24AI

**WARNING: IMPORTANT NOTICE**

A SOLID METAL BASE PLATE (SEE TABLE) MUST BE IN PLACE WHEN THE FURNACE IS INSTALLED WITH SIDE AIR RETURN DUCTS. FAILURE TO INSTALL A BASE PLATE COULD CAUSE PRODUCTS OF COMBUSTION TO BE CIRCULATED INTO THE LIVING SPACE AND CREATE POTENTIALLY HAZARDOUS CONDITIONS.

FURNACE WIDTH IN. [mm]	SOLID BOTTOM KIT NO.	BASE PLATE NO.	BASE PLATE SIZE IN. [mm]
14 [356]	RXGB-D14	AE-61874-01	11 <sup>5</sup> / <sub>8</sub> x 23 <sup>9</sup> / <sub>16</sub> [295 x 598]
17 <sup>1</sup> / <sub>2</sub> [445]	RXGB-D17	AE-61874-02	15 <sup>1</sup> / <sub>8</sub> x 23 <sup>9</sup> / <sub>16</sub> [384 x 598]
21 [533]	RXGB-D21	AE-61874-03	18 <sup>5</sup> / <sub>8</sub> x 23 <sup>9</sup> / <sub>16</sub> [473 x 598]
24 <sup>1</sup> / <sub>2</sub> [622]	RXGB-D24	AE-61874-04	25 <sup>5</sup> / <sub>8</sub> x 23 <sup>9</sup> / <sub>16</sub> [651 x 598]

**For High Altitudes**

**OPTION CODE FOR HIGH ALTITUDE: U.S.**

None required for high altitudes.

**HIGH ALTITUDE CONVERSION KITS: U.S.**

None required for high altitudes.

**80+ HIGH ALTITUDE INSTRUCTIONS**

**CAUTION:** Always follow National Fuel Gas Code (NFGC) guidelines when converting for high altitudes.

High altitude option codes are not required for these models. However, the burner orifice size needs to be recalculated and verified at elevations above 2000 ft. See Installation Instructions for more information.

[ ] Designates Metric Conversions



**Select** series



**GENERAL TERMS OF LIMITED WARRANTY\***

WeatherKing will furnish a replacement for any part of this product which fails in normal use and service within the applicable period stated, in accordance with the terms of the limited warranty.

Parts ..... Five (5) Years  
Heat Exchanger ..... Ten (10) Years

**\*For complete details of the Limited and Conditional Warranties, including applicable terms and conditions, contact your local contractor or the Manufacturer for a copy of the product warranty certificate.**

**Before proceeding with installation, refer to installation instructions packaged with each model, as well as complying with all Federal, State, Provincial, and Local codes, regulations, and practices.**

© 2022 Rheem Manufacturing Company. WeatherKing trademarks owned by Rheem Manufacturing Company.

*"In keeping with its policy of continuous progress and product improvement, WeatherKing reserves the right to make changes without notice."*

WeatherKing • 5600 Old Greenwood Road  
Fort Smith, Arkansas 72908 • [www.weatherking.com](http://www.weatherking.com)